

medulloblastoma cell lines

Abstract	58
Introduction	59
Materials and Methods	64
Results	70
Discussion	93
References	99

Chapter 4 109

The pattern of p27kip1 expression shows a correlation with focal inhibition of proliferation and differentiation in medulloblastoma

Abstract	110
Introduction	111
Materials and Methods	114
Results	117
Discussion	126
References	130

Chapter 5 135

Conclusions

Contribution to original knowledge	135
Conclusions	136
References	140

List of Abbreviations

Adenomatous polyposis coli.....	APC
Bromodeoxyuridine.....	BrdU
Central Nervous System.....	CNS
Cyclin dependent kinase.....	cdk
Cdk inhibitor protein 1.....	cip1
Diacylglycerol.....	DAG
Dihydrofolate reductase.....	DHFR
External granular layer.....	EGL
Inositol 1, 4, 5 triphosphate.....	IP ₃
Inositol 4, 5 - biphosphate.....	PIP ₂
Loss of heterozygosity.....	LOH
Microtubule associated protein - 2.....	MAP-2
Mitogen activated protein kinase.....	MAPK
Multiple tumor suppressor 1.....	MTS1
Nerve growth factor receptor.....	NGFR
Phosphotidyl inositol 4, 5 - biphosphate.....	PIP ₂
Phorbol 12-myristate 13-acetate.....	PMA
4- α - phorbol 12-myristae 13 acetate.....	4- α -PMA
Conventional Protein kinase C.....	cPKC
Novel Protein kinase C.....	nPKC
Atypical Protein kinase C.....	aPKC

Phospholipase C γ	PLC γ
Phospholipase D.....	PLD
Phosphatidylserine.....	PS
Polymerase chain reaction.....	PCR
Primitive neuroectodermal tumors.....	PNET
Proliferating cell nuclear antigen.....	PCNA
Proliferation index.....	PI
Retinoblastoma.....	RB
RNAse protection assay.....	RPA
Single strand conformation polymorphism.....	SSCP
Terminal deoxynucleotidyl transferase.....	Tdt
Thymidine kinase.....	TK
Transforming growth factor β 1 and β 2.....	TGF β 1 & β 2

Acknowledgement

I would like to express my sincere appreciation to everyone who helped along the way in making this seemingly unending and tedious journey exciting and fruitful. I would like to acknowledge the thoughtful advice and comments of members of my advisory committee, Drs G Hendy, M Park, S Jothy and V W Yong, as well as Dr H Goldsmith for his support. Special thanks to my supervisor, Dr Josephine Nalbantoglu for her support and continued encouragement especially during the difficult moments and when I was at the "crossroad". Many thanks to members of the Neuroimmunology laboratory for the friendly and collegial work environment. Finally, I would like to acknowledge the unflinching support and love of my wife, Tomi, and children, Oreofe and Oreoluwa who endured my long working hours and absence from home.

Statement of Originality

This thesis describes the analysis of the role of p53 gene mutation and mdm gene 2 amplification in the biology of medulloblastoma. This component of the project was initially "conceived" when I was in the laboratory of Dr W Cavenee who provided the extracted DNA of medulloblastomas used in this study. The analysis for gene mutation and Southern blotting for gene amplification were done by me. These results have been published [Adesina AM, Nalbantoglu J and Cavenee WK: *Cancer Res* 54:5649, 1994]

The second component of this project involved the analysis of medulloblastoma cell lines for the role of PKC - mediated signaling in cellular proliferation. All the experiments were carried out by me. Both Nora Dooley and Dr Yong are included as co-authors of the manuscript originating from this study. N Dooley, graduate student in the laboratory of Dr V W Yong provided the DNA sequence (prepublication) for the RT-PCR of cPKC isoforms, the DNA sequence for the antisense oligonucleotide to PKC α and technical advice.

The third component of this project involves the immunohistochemical analysis of medulloblastoma tumors for the expression of cell cycle related genes, p53, p21cip1, p27kip1, Bcl2, Ki-67 (MIB1) and for apoptosis. T Dunn is included as a co-author on this paper. T Duna, helped with cutting 5 μ m histology sections and provided antibodies for the p53 and MIB1 analysis.

All the work described in chapters 2, 3 and 4 should be considered as "contribution to original knowledge".

Preface

Manuscripts and authorship

Candidates have the option of including, as part of the thesis, the text of a paper(s) submitted or to be submitted for publication, or the clearly-duplicated text of a published paper(s). These texts must be bound as an integral part of the thesis.

If this option is chosen, connecting texts that provide logical bridges between the different papers are mandatory. The thesis must be written in such a way that it is more than a mere collection of manuscripts; in other words, results of a series of papers must be integrated. The thesis must still conform to all other requirements of the "Guidelines for Thesis Preparation". The thesis must include: A table of contents, an abstract in English and French, an introduction which clearly states the rationale and objectives of the study, a comprehensive review of the literature, a final conclusion and summary and a thorough bibliography of reference list. Additional material must be provided where appropriate (e.g. in appendices) and in sufficient detail to allow a clear and precise judgement to be made of the importance and originality of the research reported in the thesis.

In the case of manuscripts co-authored by the candidate and others, the candidate is required to make an explicit statement in the thesis as to who contributed and to what extent. Supervisors must attest to the accuracy of such statements at the doctoral oral defense. Since the task of the examiners is made more difficult in these cases, it is in the candidate's interest to make perfectly clear the responsibilities of all the authors of the co-authored papers. Under no circumstance can a co-author of any component of such a thesis serve as an examiner for that thesis.

Abstract

Loss of heterozygosity is common for the short arm of chromosome 17 in medulloblastomas with putative medulloblastoma suppressor loci localized to 17p13. The colocalization of the p53 tumor suppressor gene to 17p13 raises the possibility that its mutant alleles may play a role in the malignant transformation of "medulloblasts". Here we have analysed polymerase chain reaction amplified products of exons 4-9 (95% of reported p53 mutations occur within this region) of the p53 gene in 9 medulloblastomas for potential mutations using the technique of single strand conformation polymorphism (SSCP) analysis and DNA sequencing. We found only one mutation, an A-T to T-A transversion involving the second base of codon 285 and resulting in the substitution of Valine for Glutamic acid. In none of eight of these tumors could amplification of the mdm2 gene be detected. These findings suggest that genetic events associated with the inactivation of p53 gene occur in only a minor subset of medulloblastomas.

Furthermore, we have investigated the role of PKC-mediated signalling in the proliferation of medulloblastoma cell lines DAOY, D283-Med and D341-Med. By Western blot analyses, conventional PKC (cPKC) α was detectable in DAOY only, while atypical PKC (aPKC) ζ was present in all three cell lines. cPKC β 1, β 11, γ , novel PKC (nPKC) δ , and ϵ were not detectable in all cell lines. Antisense oligonucleotides to cPKC α , Calphostin C (a specific PKC inhibitor) and prolonged treatment with phorbol 12-myristate 13-acetate (PMA) with downregulation of cPKC α caused a decrease in proliferation in DAOY and no effect on D283-Med. PMA treatment was associated with

upregulation of p21cip1 in DAOY. Since cPKC α is the only PMA responsive isoform in DAOY, this observation implicates the cPKC α isoform in the proliferation of DAOY but not in D283-Med. A comparison of DAOY and D283-Med showed a higher proliferation index in DAOY. In contrast, multiprobe ribonuclease protection assay revealed higher levels of p27 kip1 and p21 cip1 mRNA in D283-Med. These transcripts were barely detectable in untreated DAOY. These observations indicate possible significant molecular heterogeneity among medulloblastomas with implications for differing biology among medulloblastoma cell lines and tumors.

We also investigated p27kip1 and p21cip1 immunoreactivity in medulloblastoma tumors. We found an inverse relationship between p27kip1 expression and proliferation. Focal islands of neuroblastic differentiation expressed high levels of p27kip1. In contrast, the undifferentiated highly proliferative population of tumor cells showed no detectable p27kip1 expression. In addition, there was no detectable p21cip1 expression in all of the medulloblastomas. There was no relationship between the detection of p53 protein and lack of p21cip1 expression. Similarly, positivity for p53 protein did not show any relationship with proliferation or apoptotic index. The low level of apoptosis in these tumors was not associated with the expression of Bcl2. These findings suggest a role for p27kip1 in cell cycle control in medulloblastoma. Since, p21cip1 and p27kip1 are often coexpressed along with other INK4 family of cdk inhibitors during the induction of cell differentiation and are synergistic in their effect, a deregulation of the coordinate expression of p21cip1 and p27kip1 may underlie the lack of complete differentiation in medulloblastoma.

Résumé

Les médulloblastomes démontrent souvent une perte d'hétérozygoté sur le bras court du chromosome 17 et un locus de suppression tumorale a été postulé en position 17p13. La co-localisation du gène de la p53, un suppresseur de tumeurs situé en 17p13 laisse sous-entendre que des allèles mutés de ce gène pourraient jouer un rôle dans la transformation tumorale de cellules souches dites "médulloblastes". Afin d'examiner cette possibilité, nous avons fait l'analyse de la séquence du gène de la p53 dans 9 médulloblastomes par amplification des exons 4-9 (où se retrouvent 95% des mutations) avec une réaction à polymérisation en chaîne suivi d'une analyse de polymorphisme conformationnel de simple brin et du séquençage de l'ADN. Cette analyse a révélé une mutation dans une seule tumeur qui correspondait à la substitution d'un A-T en T-A au codon 285 résultant en un remplacement de l'acide aminé acide glutamique par la valine. Aucune des tumeurs n'avaient une amplification génique du locus *mdm2*. Ces résultats suggèrent que l'inactivation du gène de la p53 est un évènement peu commun dans les médulloblastomes.

Nous avons aussi étudié le rôle que joue la protéine kinase C (PKC) dans la croissance des lignées cellulaires de médulloblastomes, les cellules DAOY, D283-Med et D341-Med. Par analyse d'immunobuvardage, l'isoforme α de la PKC était détectable uniquement dans les cellules DAOY alors que l'isoforme ζ était présente dans chacune des trois lignées cellulaires tandis que les autres isoformes de la PKC conventionnel (β 1, β 11, γ , δ , ϵ) étaient absentes. Le traitement avec des inhibiteurs de la PKC tels que des oligonucléotides antisens à la PKC α , à la calphostine C et une incubation de longue

durée avec le phorbol 12-myristate 13-acétate (PMA) résultèrent en une baisse de la croissance des cellules DAOY sans aucun effet sur les cellules D283-Med. Le traitement des cellules DAOY avec le PMA était associé à une augmentation de l'expression du gène du p21cip1. Comme l'isoforme α est le seul isoforme exprimé par les cellules DAOY, nos résultats suggèrent que la PKC α joue un rôle important dans la croissance cellulaire des cellules DAOY et non des cellules D283-Med. En plus, une analyse de protection à la ribonucléase a démontré des niveaux d'expression plus élevés des gènes du p21cip1 et p27kip1 dans les cellules D283-Med qui prolifèrent beaucoup moins vite, une autre indication de l'hétérogénéité moléculaire des tumeurs et lignées cellulaires de médulloblastome.

Nous avons aussi analysé par immunohistochimie les niveaux des protéines p21cip1 et p27kip1 dans les médulloblastomes. L'expression de la protéine p27kip1 était reliée d'une façon inverse aux taux de croissance des cellules tumorales dans les régions démontrant une différenciation neuronale exprimant des niveaux élevés de p27kip1. Par contre, les régions contenant des cellules ayant un taux de croissance élevé n'avaient aucun signal pour p27kip1. La protéine p21cip1 n'était détectable dans aucune des tumeurs. Aucune corrélation n'a pu être établie entre les niveaux de la p53 et l'absence de la p21, un gène contrôlé par la p53. La présence de la protéine p53 n'affecta pas non plus la capacité d'apoptose qui elle-même n'était pas reliée à la protéine Bcl-2. Nos résultats suggèrent que la p27kip1 pourrait jouer un rôle important dans le contrôle du cycle cellulaire dans les médulloblastomes et que l'absence de la p21cip1 pourrait affecter le manque de différenciation des médulloblastomes.

CHAPTER 1

INTRODUCTION AND LITERATURE REVIEW

Medulloblastoma and related primitive neuroectodermal tumors represent a significant group of central nervous system tumors (CNS) that occur predominantly in the pediatric population and less frequently in the adult population. They account for 25% of childhood intracranial tumors and are the second most common malignant tumors in childhood (1). Histologically, most of these tumors are composed of sheets of undifferentiated cellular elements while a minority exhibit focal areas of glial, neuronal, rhabdomyosarcomatous and melanocytic differentiation (1).

Historically, morphologic classifications of brain tumors have been based on the pattern of differentiation and the presumed histogenetic origin of the tumor cells. Bailey and Cushing (2) proposed the name medulloblastoma for a specific group of highly aggressive childhood tumors that they presumed arose from the putative stem cell "medulloblast" in the cerebellum. Although this name has been widely used for these tumors over the years, the "medulloblast" has remained undefined and has no counterpart in neurogenesis. In recent years, the morphologic similarity between medulloblastoma and other primitive neuroectodermal tumors, such as ependymblastoma and pineoblastoma which arise from other sites has been emphasized. This has led to the suggestion for the use of the unifying terminology of primitive neuroectodermal tumors (PNETs) for these tumors irrespective of their primary site of development in the CNS (3).

Numerous studies have been directed at understanding the histogenesis and possible underlying genetic defects playing a role in the malignant transformation of

medulloblastoma. It has been shown that primitive neuroectodermal tumors express antigens that recapitulate molecular milestones in neuroblastic differentiation (4). In the developing brain, the external granular layer (EGL) of the cerebellum shows a distinct subpial proliferative zone containing cells that mark with antibodies to proliferating cell nuclear antigen (PCNA) or Ki-67, and the nerve growth factor receptor (NGFR) but are negative for class III β tubulin and calbindin- D_{28k} . The deep postmitotic premigratory zone of the EGL contains cells which mark for class III β tubulin, microtubule associated protein (MAP)2, MAP5, and tau (5-7). Neither the deep nor the subpial zones of the EGL mark for calbindin- D_{28k} . In contrast, the immature neuroepithelial cells of the intermediate and mantle zones of the ventricular germinal matrix variably express calbindin- D_{28k} and class III β tubulin (5).

Using the expression of class III β tubulin and calbindin- D_{28k} as differentiating markers, analysis of the immunohistochemical profile of medulloblastomas have suggested that the EGL type cells may be the probable histogenetic origin of desmoplastic medulloblastoma while classic medulloblastoma may arise from the subependymal germinal matrix type cells (5,7,8). Combining both cytological features and the pattern of expression of differentiation markers, the component cells in medulloblastoma have been further subdivided into neuroblastic (Nb) phenotypes 1 - 4 (5). Nb1 and Nb2 cells represent primitive PCNA positive cells which differ in being class III β tubulin negative and positive, respectively, while Nb3 represents predominantly PCNA negative cells and Nb4 represents PCNA negative and class III β tubulin positive ganglion cells. The Nb3 cells typify the cells

seen in the neuroblastic pale islands of desmoplastic medulloblastoma. Nb1 and Nb2 typify the cells seen in the proliferative population of classic medulloblastomas and desmoplastic medulloblastoma. While all medulloblastomas are uniformly fatal unless the tumor can be completely resected, it is noteworthy that the desmoplastic medulloblastoma represents a better prognostic group, in terms of length of survival when compared with the classic medulloblastoma (9). Other features which confer a better prognosis include, onset at age > 10 years, lateral cerebellar origin and absence of metastases at initial diagnosis (9).

Numerous efforts have been directed at identifying the underlying genetic defects that may play a role in the malignant transformation of medulloblastoma. Cytogenetic and molecular studies in some medulloblastomas have shown a frequent occurrence of isochromosome 17q (10) along with monosomy for 17p or trisomy for 17q and loss of heterozygosity for chromosomes 17p, 10 and 21 (11-14). The initial co-localization of the frequent 17p deletions (reported in 45% of medulloblastomas) and loss of heterozygosity (LOH) in medulloblastomas with the p53 gene locus suggested the possible role of genetic events involving the p53 gene in the biology of medulloblastoma (11). Further analysis suggested that the 17p locus in medulloblastoma may be independent of the p53 gene locus and that there might be more than one 17p locus involved in medulloblastoma (12,13). We and others have confirmed that genetic events involving p53 may be infrequent in medulloblastoma (15,16). In spite of the low frequency of p53 mutations in medulloblastoma, the possible relevance of the observed 17p deletions in the biology of medulloblastoma is suggested by the report of a shortened survival in patients whose tumors exhibit a 17p deletion (17).

More recent studies using microsatellite markers have reported frequent LOH at locus F13B on chromosome 1q in human medulloblastomas (18), as well as a correlation between LOH on chromosome 9q22.3-q31 and the desmoplastic subtype of medulloblastoma (19). The chromosome 9q22 locus co-localizes with that of the gene involved in the autosomal dominant disorder that predisposes to the nevoid basal cell carcinoma syndrome, a syndrome characterized by the development of basal cell carcinoma of the skin, ovarian fibroma and medulloblastoma (20). Medulloblastoma also occurs in patients with Turcot's syndrome, a syndrome characterized by the concurrence of familial adenomatous polyposis and brain tumors with a high frequency of medulloblastoma (21). Germline mutations involving the adenomatous polyposis coli (APC) gene is the predominant genetic abnormality seen in families with this syndrome, although mutations involving DNA mismatch repair genes, hMLH1 or hMSP2, have also been described in a few families (21). However, no mutations in these genes have been reported in sporadic medulloblastomas (22). The occurrence of medulloblastoma as part of a syndrome complex continues to be a strong indicator of the possible role of specific genetic events in the malignant transformation of medulloblastoma.

Studies directed at identifying patterns of oncogene amplification or overexpression have reported only a few examples of medulloblastoma tumors and cell lines with elevation of *c-myc* expression, amplification of *c-myc* and *c-erb1* genes (23-25), elevation of *N-myc* expression (26) and activation of the *N-ras* oncogene (27). A study has reported a poor prognostic significance in tumors expressing the *c-erbB2* oncogene product (28). We have not been able to confirm the relationship between *c-erbB2* expression and survival in

medulloblastoma (unpublished observations). None of the above studies have identified a consistent pattern of genetic events that may explain the biology of medulloblastoma.

Histogenetically, medulloblastomas have been proposed to arise from primitive stem cells which may have been arrested during their migration from the germinal matrix (7). Such displaced cells, as well as excess precursor cells that do not establish normal neuronal synaptic connections, are eliminated during embryogenesis by apoptosis (29). It would appear that the underlying defect in medulloblastoma is a lack of response to differentiation inducing factors and / or to factors that induce apoptosis. It would appear therefore, that the deregulation of genes critical in the control of cell cycle progression and apoptotic mechanisms may be the direct or indirect targets of genetic events predisposing to neoplasia in medulloblastoma. Information on the *molecular factor/s* underlying the deregulation of cell cycle progression in medulloblastomas is currently lacking and the nature of the deregulation of classical signaling pathways in medulloblastoma is also currently poorly understood.

Although the specific signaling cascade or pathway involved in neuronal differentiation is poorly understood, a pre-requisite for the induction of terminal differentiation is the termination of the cell's progression through the cell cycle by the prevention of G₁/S transition. Furthermore, cell cycle progression and mitosis are tightly controlled by the coordinate expression and precisely timed inactivation of the cyclin-cyclin dependent kinase (cyclin-cdk) complexes (30-33). Gene amplification with resulting overexpression of either component of the cyclin-cdk complex (reviewed in ref. 34), as well as the loss of the expression of cdk regulatory proteins (i.e. inhibitors), such as p21cip1

secondary to p53 inactivation, are associated with abnormal cyclin-cdk activity and a deregulation of cell cycle control. (35,36). It may be relevant to explore the nature of the deregulation of second messenger signaling pathways and cell cycle control genes in an effort to understand the events that are critical for the malignant phenotype observed in medulloblastomas. This is particularly relevant, if we are to be able to develop appropriate therapeutic modalities, including gene therapy, that may alter the current abysmal prognosis and survival rate of children with medulloblastoma (37). It is noteworthy that 5 year survival rates range from 17% in the 0 - 3 year age group to 54% for children > 10 years (9) and 65% overall survival for all age groups (37).

Protein kinase C and signal transduction

PKC is a multigene family of serine / threonine kinases initially characterized through their activation *in vitro* by Ca^{2+} , phospholipid and DAG (38). There are 11 isoforms currently identified. These include: (i) the Ca^{2+} dependent PKC α , $\beta 1$, $\beta 11$ and γ ; (ii) Ca^{2+} independent PKC δ , ϵ , η , θ and μ and (iii) atypical PKC ζ and λ (reviewed in ref.39). While the mRNAs for PKC $\beta 1$ and $\beta 11$ are generated by alternative splicing from the same PKC β gene, and differ only in the sequence of 50 amino acids at the carboxyl-terminal end, the other PKC isozymes have been localized to different chromosomes (40). PKC isoforms show differential tissue distribution with PKC α , δ and ζ found in all tissues and PKC γ present in brain and spinal cord. The other isoforms show significant variation in their tissue distribution (39,40).

Classical PKC isoform possesses 4 conserved regions C1 - C4 and 5 variable regions V1 - V5. C1, C2, V1 and V2 form the regulatory domain while C3, C4, V4 and V5 form the catalytic domain. V3 represents the hinge region allowing the enzyme to fold on itself (Figure 1). The catalytic domain is located at the carboxy-terminal end and shows a high degree of homology, not only between PKC isozymes, but with other serine / threonine kinases and tyrosine kinases (40). The C3 and C4 regions contain the ATP binding site and the substrate binding site, respectively. The regulatory domain possesses the binding site for various regulators of PKC activation. The C1 region has a sequence rich in basic amino acid residues in which alanine is substituted for serine / threonine to produce a pseudosubstrate site. This site binds to the substrate recognition site of C4 and renders the isozyme inactive (41). The C1 region also contains a tandem repeat of 2 cysteine-rich zinc finger structures, the first of which binds DAG and phorbol esters while the second binds phospholipids. It is noteworthy that in PKC ζ and λ , only one zinc finger is present in their C1 region resulting in the loss of the ability to bind DAG and phorbol esters (39). In addition, the C2 region which contains the Ca^{2+} binding site is absent in PKC δ , ϵ , η , θ , μ and the atypical PKC ζ and λ thus making them Ca^{2+} independent.

PKC activation occurs via signal transduction cascades (Figure 2) that produce DAG from the hydrolysis of phosphatidyl inositol 4,5-bisphosphate (PIP_2) into inositol 1,4,5-trisphosphate (IP_3) and DAG by phospholipase C (PLC) γ . The activation of PLC γ occurs via SH_2 domain interaction with phosphotyrosine residues on activated tyrosine kinase receptors or via interaction with activated G proteins (reviewed in ref. 39,42). The IP_3 released

Figure 1 PKC and signal transduction. Activation of receptors coupled to PLC results in the hydrolysis of PIP₂ and elevation of DAG leading to the activation of PKC. PKC activation triggers a sequence of phosphorylation events that lead to transcriptional activation of phorbol ester inducible genes. This transcriptional activation is mediated through two independent pathways, the *raf1/MAPK* and the *IκB/NFκB* pathways (Adapted from ref. 40).

PKC and signal transduction

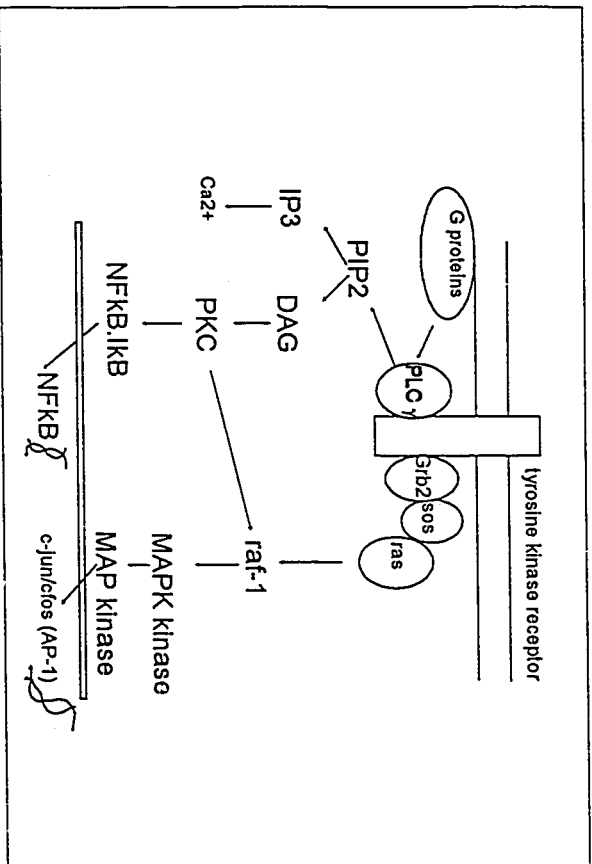
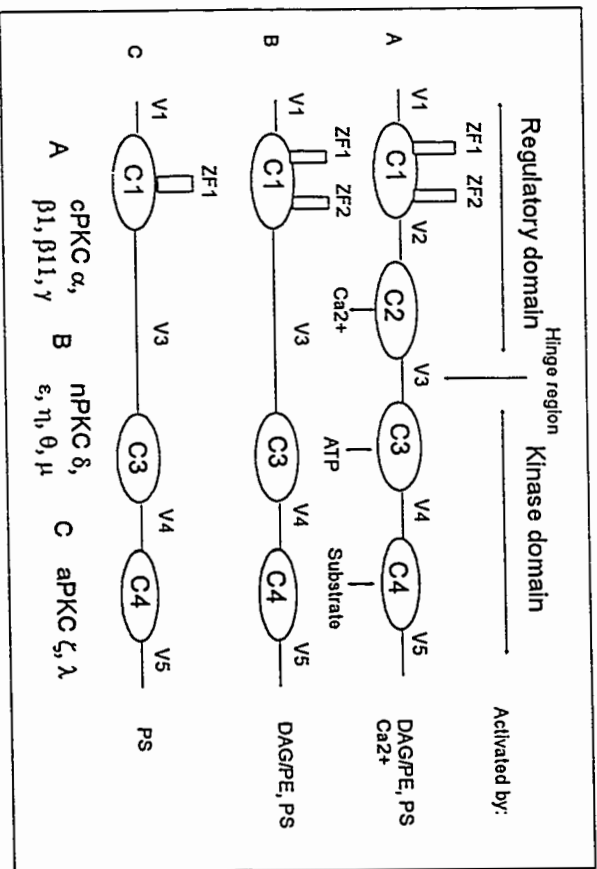

Figure 2 Structure of PKC isozymes. PKC isoforms have been classified into three different groups. Group A (classical PKC isozymes) includes PKC α , $\beta 1$, $\beta 11$ and γ . They are Ca^{2+} dependent and activated by phosphatidylserine (PS) and DAG/phorbol esters. Group B (novel PKC isozymes) includes PKC δ , ϵ , η , θ , and μ . They are Ca^{2+} independent and are activated by PS and DAG/phorbol esters. Group C (atypical PKC isozymes) includes PKC ζ and λ . They are not receptors for DAG/phorbol esters and are Ca^{2+} independent.

Structure of PKC Isozymes



following the hydrolysis of PIP_2 mobilizes Ca^{2+} which binds the C2 region and causes a translocation of PKC from the cytosol to the cell membrane where it binds to the DAG generated by the hydrolysis of PIP_2 . The activation of PKC then generates a cascade of signaling events that lead to the nuclear translocation of nuclear factor (NF)- κB by phosphorylating I κB and removing its inhibitory effect on the NF κB .I κB complex (43). Alternatively, PKC and specifically PKC α , may activate the mitogen activated protein (MAP) kinase pathway by phosphorylating and activating *raf-1* (44). The MAP kinase pathway activation leads to the induction of transcription by AP-1 (*c-jun/c-jun* homodimer or *c-jun/c-fos* heterodimer) and AP-2 on genes that bear the TPA response element. Sustained PKC activation results from a second phase of generation of DAG through the hydrolysis of phosphatidylcholine by phospholipase D (PLD) to phosphatidic acid. Phosphatidic acid is then converted to DAG by a phosphomonoesterase. The activation of PLD presumably occurs via tyrosine kinase activity or by PKC activity as well (reviewed in ref. 40,42).

In the central nervous system, PKC has been implicated in long term potentiation in neurons (45), neurite extension (46,47), release of neurotransmitters (38) and process formation in oligodendrocytes (48,49) as well as the differentiation (50,51), morphology (52,53) and proliferation of astrocytes (54-56). Numerous studies continue to indicate a differential role for specific PKC isoforms in cell cycle regulation. These studies suggest that the overall observed effect of PKC activation is tissue-specific and isoform dependent. The effects attributed to different PKC isoforms range from cellular proliferation induced by PKC α overexpression in Swiss/3T3 fibroblasts (57) to the induction of terminal differentiation by

PKC β in murine erythroleukemia cells (58) and growth suppression in human colon carcinoma cell lines by PKC β I (59). In addition, PKC α and / or δ have been observed to be involved in PKC mediated suppression of apoptosis by PMA in a plasmacytoma cell line (60) while activation of PKC by PMA inhibits apoptosis in HL-60 promyelocytic leukemia cells (61). Also, loss of PKC α expression correlates with the induction of differentiation in adipocytes (62) while the down regulation of PKC α partially abrogates the mitogenic response of Swiss 3T3 cells to bombesin and totally suppresses the mitogenic response of Swiss 3T3 cells to PMA activation (63). In rat C6 glioma cell lines, overexpression of PKC α correlates with the malignant phenotype and rat C6 glioma cell proliferation can be inhibited by treatment with antisense oligonucleotides to PKC α (64). In PC12 cells, PKC δ has been implicated in NGF induced neural differentiation (47).

Furthermore, the effect of phorbol ester stimulation of PKC is not only isoform dependent and tissue specific (65,66), the observed effects may also be cell cycle dependent in some cells. These effects are presumed to be partly related to a complex array of PKC-cyclin dependent kinase (cdk) signaling pathways which influence cell cycle control by inhibiting DNA synthesis when activated in the late G₁ phase, or potentiating growth factor-induced DNA synthesis when activated during early G₁ phase (67,68). These examples illustrate the significant diversity that exists in the function of different PKC isoforms, depending on the tissue and the biological context.

Cell Cycle Regulation

The cell cycle is characterized by the progression of cells through a sequence of phases starting with active protein synthesis (G_1), followed by DNA synthesis (S phase), mitosis (M phase) and ultimate cell division to produce daughter cells. Cells respond to extracellular signals in G_1 by either advancing toward another division or withdrawing into a resting (G_0) state with or without differentiation (reviewed in ref. 69,70). The decision to divide occurs as cells pass the restriction point in late G_1 (Figure 3) after which they become refractory to extracellular growth regulatory signals (reviewed in ref. 69,70). Transition from G_1 to S phase is dependent on the activity of cdk's (cdk2,cdk3, cdk4,cdk5 and cdk6) that are sequentially regulated by cyclins D,E and A. The activation of cdk results from the phosphorylation of threonine / tyrosine residues and the binding of cyclins (reviewed in ref. 34) while inhibition of cdk activity is dependent on the activity of at least two families of cdk inhibitors (reviewed in ref. 71, 72). D-type cyclins are induced following growth factor stimulation and combine with cdk4 and cdk6 (reviewed in 70) to form active complexes. Cyclin-cdk complex activities are first noted in mid- G_1 and increase to maximum at the G_1 -S transition. Withdrawal of mitogen stimulation is accompanied by cessation of cyclin D synthesis and exit from the cell cycle. G_1 phase arrest can also be achieved by the INK4 family of cdk inhibitors which include p16^{INK4a}, p15^{INK4b}, p18^{INK4c} and p19^{INK4d} (reviewed in ref.34). These inhibit the activity of cdk4 and cdk6.

The cyclin-cdk complexes induce cell cycle progression by the modification of substrates such as the retinoblastoma gene protein product, RB, and related proteins whose activities are normally required for cell cycle exit (Figure 4) [reviewed in ref. 34]. In the

Figure 3 Cell cycle. Progression of mitogenically stimulated cells through the cell cycle involves the synthesis, progressive accumulation and activation of cyclin D and cyclin dependent kinase (cdk2, cdk4, cdk6) complexes in early G₁. In late G₁, there is accumulation and increased activity of the cyclin E-cdk2 complex leading to transition beyond the restriction point. Once the restriction point is passed, progression through the cycle is independent of mitogenic stimulation. The S phase is characterized by the activity of the cyclin A-cdk2 complex while G₂ / M phase is characterized by cyclin A/B-cdk1 activity. Exit from M to G₁ or G₀ requires the ubiquitin mediated hydrolysis of cyclin B (Adapted from ref. 34)

Cell cycle

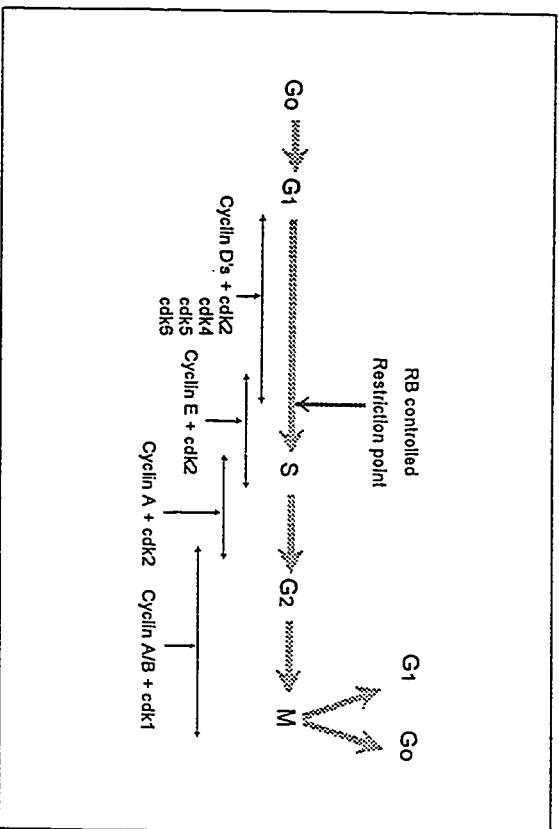
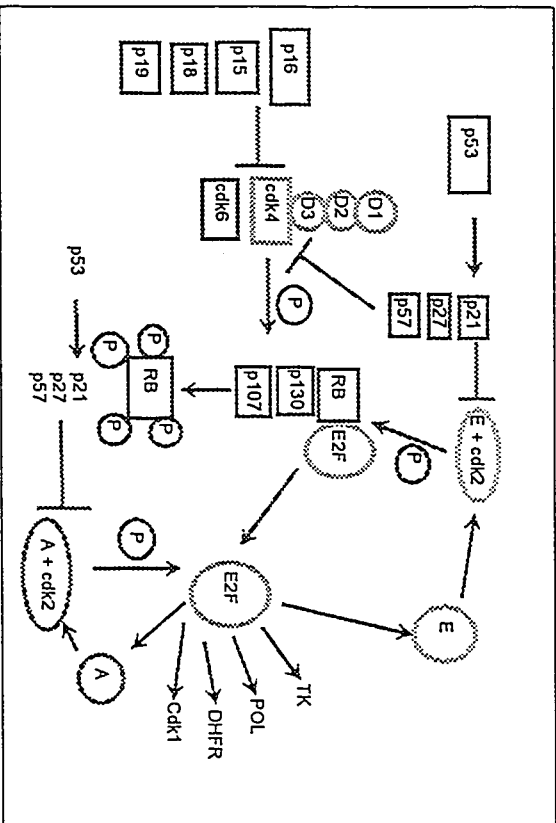

Figure 4 Restriction point control. RB phosphorylation is triggered by cyclin D-cdk complexes resulting in the release of Rb-bound E2F. E2F activates the expression of thymidine kinase (TK), DNA polymerase α (POL), dihydrofolate reductase (DHFR), cyclin dependent kinase, *cdk1* (*cdc2*) and cyclin A. p21, p27, p57 and the INK4 (p16, p15, p18, p19) family of proteins are cdk inhibitors which inhibit the phosphorylation of RB by the cyclin D-cdk complexes. Expression of p21 can be regulated by p53 protein. (Adapted from ref. 34).

Restriction point control



hypophosphorylated state, RB and other related proteins, such as p107 and p130, form a complex with the E2F family of heterodimeric transcriptional regulators, thereby preventing the transactivation of genes involved in DNA synthesis (reviewed in ref. 73). This binding affinity is lost in the hyperphosphorylated state thus releasing E2F from the inhibitory effect of RB. RB phosphorylation is initiated by the cyclin D-cdks and accelerated by the cyclin E - cdk2 complex (Figure 4) [reviewed in ref. 34,74,75].

While cyclin D expression does not alter significantly throughout the cell cycle, cyclin E expression is periodic and maximal at the G₁-S transition. In addition, the cyclin E gene is E2F responsive, so that cyclin E-cdk complex can generate a positive feedback that facilitates multiple rounds of RB phosphorylation and release of E2F from RB inhibition. On entering S phase, cyclin E activity is terminated through an ubiquitin-mediated proteolysis. The proteolysis of cyclin E and the phosphorylation of E2F by the accumulation of cyclin A-cdk2 complex subsequently terminate E2F mediated transactivation of transcription (reviewed in ref. 34).

A second family of cdk inhibitors include p21cip1, p27kip1 and p57kip2 (reviewed in ref. 34,36). These cdk inhibitors are coordinately expressed during differentiation (30). While p21cip1 expression can be p53 dependent (33,35) or p53 independent (30,31) and p21cip1 functions predominantly in growth control following DNA damage, p27kip1 is probably most directly involved in restriction point control (reviewed in ref. 34). The role of p27kip1 in growth control is demonstrated by the inability to maintain a quiescent state in cells transfected with antisense cDNA for p27kip1 (76) and the frank organomegaly and pituitary tumors seen in the p27kip1 gene nullizygous mice (77). Sequestration of p27kip1

into excess cyclin D-cdk complexes (78) and the acceleration of p27kip1 turnover through a cyclinE-cdk2 mediated phosphorylation (reviewed in ref. 34) play significant roles in the post-translational control of the levels of p27kip1. Progression through mitosis is dependent on the activity of cyclin B-cdk1 and exit from mitosis requires an ubiquitin-mediated hydrolysis of cyclin B (reviewed in ref. 34).

Genetic events and cell cycle dysregulation

Mutations and genetic alterations involving p27kip1, p21cip1 and p57kip2 are infrequent in human tumors, suggesting that this mechanism is not the preferred method of dysregulation of expression of these cdk inhibitors (79-82). However, recent studies have reported a correlation between p53 mutation and low expression of p21cip1 in gastric carcinomas and colonic adenocarcinomas (33); an observation consistent with the demonstrated role of p53 in the regulation of p21cip1 expression (35). The role of p57kip2 in cell differentiation and proliferation has been shown by the altered proliferation and differentiation of various organs in the p57kip2 deficient mice, in a pattern consistent with features seen in patients with Beckwith-Wiedeman syndrome, a hereditary disorder characterized by hemihypertrophy and predisposition to the development of Wilm's tumor (83).

Mutations of the INK4a (MTS1) gene have been described in familial melanoma, as well as biliary tract (50%) and esophageal carcinomas (30%) (reviewed in ref. 34,84) while homozygous deletions involving the INK4a locus on chromosome 9p21 occur commonly in gliomas (55%), mesotheliomas (55%), nasopharyngeal carcinomas (40%),

acute lymphocytic leukemia (30%), sarcomas, and bladder and ovarian tumors (reviewed in ref. 34). Both homozygous deletions and mutations involving INK4a are seen in pancreatic, head and neck and non-small cell lung carcinomas (reviewed in ref. 34). These observations emphasize the role of cdk inhibitors in the control of cell cycle progression and carcinogenesis. In addition to genetic events involving cdk inhibitors, genetic events involving the cyclins, especially cyclin D1 in the form of amplification or altered expression, as well as cdk4 have also been reported in many tumors (reviewed in ref. 34).

While mutations and deletions involving the INK4 family of cdk inhibitors have been reported in gliomas (reviewed in 34,85), similar analysis of medulloblastoma for p16 deletions have revealed only rare occasions of homozygous deletions of this gene (85). In spite of the rarity of reported genetic events involving the cdk inhibitors in medulloblastoma, it is still reasonable to presume that uncontrolled cell proliferation in medulloblastoma is a result of the deregulation of cell signaling and activation of mitogenic pathways. The presence of such abnormalities in the regulation of signaling pathways in medulloblastoma is supported by the correlation of lack of *trk C* expression and poor prognosis in medulloblastoma (86), overexpression of the β chain of platelet derived growth factor and its correlation with high proliferation in medulloblastoma tumors (87), and the implication of TGF β 1 and TGF β 2 in autocrine growth regulation for medulloblastomas (88). The treatment of DAOY with phenylacetate, a non-toxic differentiation inducer, is also associated with a decrease in TGF β production and decreased DNA synthesis and cell proliferation in DAOY (89). All of these observations have led to a search for second

messenger signal transducers that may play a role in the proliferation of medulloblastoma. One signal transducer that may link epidermal growth factor (EGF) and insulin receptor signaling with SH2 containing proteins and thus, with multiple signaling pathways is the Grb2 associated protein, Gab1 (90). This protein is expressed in medulloblastoma and is a substrate for EGF and insulin receptors, serving as docking protein for SH2 containing proteins. Its overexpression is associated with enhanced cell growth and transformation (90).

Rationale

In view of the earlier reports indicating a colocalization of the region of deletion of 17p in 45% of medulloblastomas with the p53 gene locus on 17p, we hypothesized that genetic events involving the p53 gene may account for the malignant transformation of medulloblastoma. In pursuance of this hypothesis, we have analysed medulloblastoma tumors for the frequency of p53 gene mutation and mdm2 gene amplification. The analyses revealed p53 mutation in a minor subset of medulloblastomas. Since the underlying mechanism/s responsible for cellular proliferation in a large proportion of medulloblastomas remained unclear, and a sequential analysis of all genes for mutations in medulloblastoma does not appear feasible, we hypothesized that genetic events that are important in the biology of medulloblastoma may be accompanied by the deregulation of the activity of a major and central second messenger signal transducer, such as PKC which is a common intermediate converging point for multiple receptor induced signals and is further linked downstream to multiple signaling pathways. Using *in vitro* cell culture of medulloblastoma cell lines, DAOY, D283-Med and D341-Med, we examined the role of PKC - mediated

signaling in the proliferation of medulloblastoma and correlated cellular responsiveness to PKC modulation with the pattern of expression of cell cycle related genes. Furthermore, we analysed medulloblastoma tumors for the pattern of expression of cell cycle regulating cdk inhibitors, p21cip1 and p27kip1 and correlated their expression or lack of expression with the expression of p53, anti-apoptosis gene product Bcl2, apoptosis index and proliferation index.

References

- 1 Russell DS, Rubinstein LJ: Pathology of tumors of the central nervous system. 5th edition, pg 251-270, 1989
- 2 Bailey P, Cushing H: Medulloblastoma cerebelli; a common type of midcerebellar glioma of childhood. *Archiv Neurol Psych* 14: 192, 1925
- 3 Rorke LB, Gilles FH, Davis RL, Becker LE: Revision of the World Health Organization classification of brain tumors for childhood brain tumors. *Cancer* 56: 1869 - 1886, 1985
- 4 Trojanowski JQ, Tohyama T, Lee VM-Y: Medulloblastoma and related primitive neuroectodermal tumors of childhood recapitulate molecular milestones in the maturation of neuroblasts. *Mol Chem Neuropathol* 17: 121 - 135, 1992
- 5 Katsetos CD, Burger PC: Medulloblastoma. *Sem Diagn Pathol* 11: 85 - 97, 1994
- 6 Katsetos CD, Frankfurter A, Christakos S, Mancall EL, Vlachos IN, Urich H: Differential localization of class III β tubulin isotype and calbindin-D_{28k} defines distinct neuronal types in the developing human cerebellar cortex. *J Neuropathol Exp Neurol* 52:655 - 666,1993
- 7 Yachnis AT, Rocke LB, Lee VM-Y, Trojanowski JQ: Expression of neuronal and glial polypeptides during histogenesis of the human cerebellar cortex including observations on the dentate nucleus. *J Comp Neurol* 334: 356 -369, 1993
- 8 Viores SDA, Herman MM, Katsetos CD, May EE, Frankfurter A: Neuron associated class III β tubulin, tau and MAP2 in the D283-Med cell line and in

- primary explants of human medulloblastoma. *Histochem J* 26: 678 - 685, 1994
- 9 Sure U, Berghoom WJ, Bertalanffy H, Wakabayashi T, Yoshida J, Sugita K, Seeger W: Staging, scoring and grading of medulloblastoma. A postoperative prognosis predicting system based on the cases from a single institute. *Acta Neurochir (Wien)* 132: 59 - 65, 1995
- 10 Bigner SH, Mark J, Friedman HS, Biegel JA, Bigner DD: Structural chromosomal abnormalities in human medulloblastoma. *Cancer Genet Cytogenet* 30: 91-101, 1988
- 11 James CD, Ju He, Carlom E, Mikkelsen T, Ridderheim P, Cavenee WK, Collins VP: Loss of genetic information in central nervous system tumors common to children and young adults. *Genes, Chromosomes and Cancer* 2: 94-102, 1990
- 12 Cogen PH, Daneshvar L, Metzger AK, Duyk G, Edwards MSB, Sheffield, VC: Involvement of multiple 17p loci in medulloblastoma tumorigenesis. *Am J Hum Genet* 50: 584-589, 1992
- 13 Biegel JA, Burk CD, Barr FG, Emanuel BS: Evidence for a 17p tumor related locus distinct from p53 in pediatric primitive neuroectodermal tumors. *Cancer Res* 52: 3391-3395, 1992
- 14 Thomas GA, Raffel C: Loss of heterozygosity on 6q, 16q and 17p in human central nervous system primitive neuroectodermal tumors. *Cancer Res* 51: 639-643, 1991
- 15 Adesina AM, Nalbantoglu J, Cavenee WK: p53 gene mutation and mdm2 gene amplification are uncommon in medulloblastoma. *Cancer Res* 54: 5649 - 5651,

1994

- 16 Saylor III RL, Sidransky D, Friedman HS, Bigner SH, Bigner DD, Vogelstein B, Brodeur GM: Infrequent p53 gene mutations in medulloblastomas. *Cancer Res* 51: 4721-4723, 1991
- 17 Batra SK, McLendon RE, Koo JS, Castelino-Prabhu S, Fuehs HE, Krischer JP, Friedman HS, Bigner DD, Bigner SH: Prognostic implications of chromosome 17p deletions in human medulloblastomas. *J Neurooncol* 24: 39 - 45, 1995
- 18 Kraus JA, Koch A, Albrecth S, Von Deirnlng A, Wiestler OD, Pietsch T: Loss of heterozygosity at locus F13B on chromosome 1q in human medulloblastoma. *Int J Cancer* 67: 11 - 15, 1996
- 19 Schofield D, West Anthony DC, Marshal R, Sklar J: Correlation of loss of heterozygosity at chromosome 9q with histologic subtype in medulloblastomas. *Am J Pathol* 146: 472 - 480, 1995
- 20 Bale AE: The nevoid basal cell carcinoma syndrome: genetics and mechanisms of carcinogenesis. *Cancer Invest* 15: 180 - 186, 1997
- 21 Hamilton SR, Liu B, Parsons RE, Papadopoulos N, Jen J, Powell SM, Krush AJ, Berk T, Cohen Z, Tetu B et al: The molecular basis of Turcot's syndrome. *New Engl J Med* 332: 839 - 849, 1995
- 22 Mori T, Nagase H, Horrii A, Miyoshi Y, Shinamo T, Nakatsuru S, Aoki T, Arakawa H, Yanagisawa A, Ushio Y et al: Germline and somatic mutations of the APC gene with Turcot's syndrome and analysis of APC mutation in brain tumors. *Genes, Chromosomes, Cancer* 9: 168 - 172, 1994

- 23 MacGregor DN, Ziff EB: Elevated *c-myc* expression in childhood medulloblastomas. *Pediatric Res* 28: 63-68, 1990
- 24 Wasson JC, Saylor III RL, Zelter P, Friedman HS, Bigner SH, Burger PC, Bigner D, Look AT, Douglas EC, Brodeur GM: Oncogene amplification in pediatric brain tumors. *Cancer Res* 50: 2987-2990, 1990
- 25 Bigner SH, Friedman SH, Vogelstein B, Oakes WJ, Bigner DD: Amplification of the *c-myc* gene in human medulloblastoma cell lines and xenografts. *Cancer Res* 50: 2347-2350, 1990
- 26 Garson JA, Pemberton LF, Sheppard PW, Vardeel IM, Coakham HB, Kemshead JT: *N-myc* gene expression and oncoprotein characterisation in medulloblastoma. *Br J Cancer* 59: 889-894, 1989
- 27 Fults D, Maness PF, Nakamura Y, White R: The *N-ras* oncogene is activated in a human medulloblastoma cell line. *Brain Res* 503: 281-287, 1989
- 28 Gilbertson RJ, Pearson ADJ, Peryy RH, Jaros E, Kelly PJ: Prognostic significance of the *c-erbB-2* oncogene product in childhood medulloblastoma. *Brit J Cancer* 71: 473 - 477, 1995
- 29 Jessel TM: Neuronal survival and synapse formation. In *Principles of neural science* (edit, Kandel ER, Schwartz JH, Jessell TM) Elsevier, New York, pg 929 - 944, 1991
- 30 Liu M, Lee M-H, Cohen M, Bommakanti M, Freedman LP: Transcriptional activation of the cdk inhibitor p21 by vitamin D3 leads to the induced differentiation of the myelomonocytic cell line U937. *Genes & Dev* 10: 142 -153, 1996

- 31 Parker SB, Eichele G, Zhang P, Rawls A, Sands AT, Bradley A, Olson EW, Harper JW, Elledge SJ: p53 independent expression of p21/cip1 in muscle and other terminally differentiating cells. *Science* 267: 1024 - 1027, 1995
- 32 Gartel AL, Serfas MS, Gartel M, Goufman E, Wu GS, El-Deiry WS, Tyner AL: p21 (waf1/cip1) expression is induced in newly nondividing cells in diverse epithelia and during differentiation of the Caco-2 intestinal cell line. *Exp Cell Res* 227: 171 -181, 1996
- 33 Doglioni C, Plosio P, Laurino L, Macri E, Meggiolaro E, Favretti F, Barbarareschi M: p21^{waf1/cip1} expression in normal mucosa and in adenoma and adenocarcinoma of the colon: its relationship with differentiation. *J Pathol* 179: 248 - 253, 1993
- 34 Sherr CJ: Cancer cell cycles. *Science* 274: 1672 - 1677, 1996
- 35 El-Deiry WS, Tokino T, Velculescu VE, Levy DB, Parsons R, Trent JM, Lin D, Mercer WE, Kinzler KW, Vogelstein B: WAF1, a potential mediator of p53 tumor suppression. *Cell* 75: 817-825, 1993
- 36 Harper JW, Adami GR, Wei N, Keyomarsi K, Elledge SJ: The p21 Cdk-interacting protein is a potent inhibitor of G₁ cyclin -dependent kinases. *Cell* 75: 805-816, 1993
- 37 Albright AL, Wisoff JH, Zelter PM, Boyett JM, Rocke LB: Effects of medulloblastoma resection on outcome in children: a report from the children's cancer group. *Neurosurgery* 38: 265 - 271, 1996
- 38 Nishizuka Y: Intracellular signaling by hydrolysis of phospholipids and activation of protein kinase C. *Science* 258: 607 - 613, 1992
- 39 Nishizuka Y: Protein kinase C and lipid signaling for sustained cellular responses.

FASEB J 9: 484-496, 1995

- 40 Kananietz MG, Blumberg PM: Protein kinase C and signal transduction in normal and neoplastic cells. In Cellular and Molecular Pathogenesis (edit, Sirica AE) Lippincott-Raven Publishers, Philadelphia, pg 389 - 402, 1996
- 41 House C, Kemp BE: Protein kinase C contains a pseudosubstrate prototope in its regulatory domain. Science 238: 1726 - 1728, 1987
- 42 Denhardt DT: Signal - transducing protein phosphorylation cascades mediated by ras/rho proteins in the mammalian cell: the potential for multiplex signaling. Biochem J 318: 729 -747, 1996
- 43 Ghosh S, Baltimore D: Activation of NF-kappa B by phosphorylation of its inhibitor I kappa B. Nature 344: 678 - 682, 1990
- 44 Kolch W, Heidecker G, Kochs G, Hummel R, Vahidi H, Mischak H, Finkenzeller G, Marme D, Rapp UR: Protein Kinase C alpha activates RAF-1 by direct phosphorylation. Nature 364: 249 - 252, 1993
- 45 Ben-Ari Y, Anikszteijn L, Biegestovki P: Protein kinase C modulation of NMDA currents: an important link for LTP induction. Trends Neurosci 15: 333 - 339, 1992
- 46 Roivainen R, McMahon T, Messing RO: Protein kinase C isozymes that mediate enhancement of neurite outgrowth by ethanol and phorbol esters in PC12 cells. Brain Res 624: 85 - 93, 1993
- 47 O'Driscoll KR, Teng KK, Fabbro D, Greene LA, Weinstein IB: Selective translocation of protein kinase C- δ in PC12 cells during nerve growth factor

- induced neuritogenesis. *Mol Biol Cell* 6: 449 - 458, 1995
- 48 Yong VW, Sekiguchi S, Kim MW, Kim SU: Phorbol ester enhances morphological differentiation of oligodendrocytes in culture. *J Neurosci Res* 19: 187 - 194, 1988
- 49 Yong VW, Dooley NP, Noble PG: Protein kinase C in cultured adult human oligodendrocytes: a potential role for isoform α as a mediator of process outgrowth. *J Neurosci Res* 39: 83 - 96, 1994
- 50 Honne P: Protein kinase C - activating tumor promoters enhance the differentiation of astrocytes in aggregating fetal brain cell cultures. *J Neurochem* 46: 1561 - 1566, 1986
- 51 Shafiq-Zagardo B, Kunne-Iwaki A, Goldman JE: Astrocytes regulate GFAP mRNA levels by cyclic AMP and protein kinase C dependent mechanisms. *Glia* 1: 346 - 354, 1988
- 52 Mobley PL, Scott SL, Cruz EG: Protein kinase C in astrocytes: a determinant of cell morphology. *Brain Res* 398: 366 - 369, 1986
- 53 Harrison BC, Mobley PL: Phorbol ester-induced change in astrocyte morphology: correlation with protein kinase C activation and protein phosphorylation. *J Neurosci Res* 25: 71 - 80, 1990
- 54 Murphy S, McCabe N, Morrow C, Pearce B: Phorbol ester stimulates proliferation of astrocytes in primary culture. *Dev Brain Res* 31: 133 - 135, 1987
- 55 Bhat NR: Role of protein kinase C in glial cell proliferation. *J Neurosci Res* 22: 20 - 27, 1989

- 56 Sawada M, Suzumura A, Ohno K, Marunouchi T: Regulation of astrocyte proliferation by prostaglandin E2 and α subtype of protein kinase C. *Brain Res* 613: 67 - 73, 1993
- 57 Eldar H, Zisman Y, Ullrich A, Livneh E: Overexpression of protein kinase C α subtype in Swiss/3T3 fibroblasts causes loss of both high and low affinity receptor numbers for epidermal growth factor. *J Biol Chem* 265: 13290 - 13296, 1990
- 58 Melloni E, Ponremoli S, Sparastove B, Patrone M, Grossi F, Marks PA, Rifkind RA: Introduction of the β isozyme of protein kinase C accelerates induced differentiation of murine erythroleukemia cells. *Proc Natl Acad Sci (USA)* 87, 4417 - 4420, 1990
- 59 Choi P, Tchou-Wong K, Weinstein IB: Overexpression of protein kinase C in HT 29 colon cancer cells causes growth inhibition and tumor suppression. *Mol Cell Biol* 10, 4650 - 4657, 1990
- 60 Romanova LY, Alexandrov IA, Schwab G, Hilbert DM, Mushinski JF, Nordan RP: Mechanism of apoptosis suppression by phorbol ester in IL-6 starved murine plasmacytoma: role of PKC modulation and cell cycle. *Biochemistry* 35: 9900 - 9996, 1996
- 61 Zhu WH, Loh TT: Differential effects of phorbol esters on apoptosis in HL-60 promyelocytic leukemia cells. *Biochem Pharmacol* 51: 1229 - 1236, 1996
- 62 McGowan K, DeVente J, Carey JO, Ways DK, Pekala PH: Protein kinase C isoform expression during the differentiation of 3T3-L1 preadipocytes: loss of

protein kinase C - alpha isoform correlates with loss of phorbol 12-myristate 13-acetate activation of nuclear factor kappa B and acquisition of the adipocyte phenotype. *J Cell Physiol* 167: 113- 120, 1996

- 63 Florin-Christensen J, Florin-Christensen M, Meinardi E, Calle R: Diversity of roles of protein kinase C alpha in the proliferation of Swiss 3T3 cells. *Biochem J* 315: 513 - 516, 1996
- 64 Baltuch GH, Dooley NP, Rostworowski KM, Villemure J-G, Yong VW: Protein kinase C isoform α overexpression in C6 glioma cells and its role in cell proliferation. *J Neuro-Oncol* 24: 241 - 250, 1995
- 65 Mischak H, Pierce JH, Goodnight J, Kananietz MG, Blumberg PM, Mushinski JF: Phorbol ester-induced myeloid differentiation is mediated by protein kinase C $-\alpha$ and $-\delta$ and not by protein kinase C $-\beta$ II, $-\epsilon$, $-\zeta$, η . *J Biol Chem* 268:20110-20115, 1993
- 66 Watanabe T, Ono Y, Taniyama Y, Hazama K, Igarashi K, Ogita K, Kikkawa U, Nishizuka Y: Cell division arrest induced by phorbol ester in CHO overexpressing protein kinase C $-\delta$ subspecies. *Proc Natl Acad Sci (USA)* 89: 10159-10163, 1992
- 67 Zhou W, Takuwa N, Kumada M, Takuwa Y: Protein kinase C-mediated bidirectional regulation of DNA synthesis, RB protein phosphorylation and cyclin dependent kinases in human vascular endothelial cells. *J Biol Chem* 268:23041-23048, 1993

- 68 Faria M, Armelin HA: Antagonistic actions of phorbol ester in mammalian G₀-> G₁-> S cell cycle transition. *Cell Growth Differ* 7: 75 - 81, 1996
- 69 Pardee AB: G₁ events and regulation of cell proliferation. *Science* 246: 603-608, 1989
- 70 Sherr CJ: G₁ phase progression: cyclin on cue. *Cell* 79: 551 - 555, 1994
- 71 Elledge SJ, Harper JW: Cdk inhibitors: on the threshold of checkpoints and development. *Curr Opin Cell Biol* 6: 847 - 852, 1994
- 72 Sherr CJ, Roberts JM: Inhibitors of mammalian G₁ cyclin-dependent kinases. *Genes & Dev* 9: 1149, 1995
- 73 Lam E W, La Thangue NB: DP and E2F proteins: coordinating transcription with cell cycle progression. *Curr Opin Cell Biol* 6:859 -866, 1994
- 74 Serrano M, Gome-hoz E, DePinho RA, Beach D, Bar-Sagi D: Inhibition of ras - induced proliferation and cellular transformation by p16INK4. *Science* 267: 249 - 252, 1995
75. Weinberg RA: The retinoblastoma protein and cell cycle control. *Cell* 81: 323 - 330, 1995
- 76 Rivard N, L'Allemain G, Bartek J, Pouyssegur J: Abrogation of p27kip1 by cDNA antisense suppresses quiescence (Go state) in fibroblasts. *J Biol Chem* 271: 18337 - 18342, 1996
- 77 Fer ML, Rivkin M, Tasch M, Porter P, Crow CE, Firpo E, Polyak K, Tsai LH, Broudy V, Perlmutter RM, Kaushansky K, Roberts JM: A syndrome of multiorgan hyperplasia with features of gigantism, tumorigenesis and female sterility in

p27(kip1)-deficient mice. *Cell* 85: 733 - 744, 1996

- 78 Polyak K, Kato JY, Solomon MJ, Sherr CJ, Massague J, Roberts JM, Koff A:
p27kip1, a cyclin-cdk inhibitor links transforming growth factor beta and contact
inhibition to cell cycle arrest. *Genes & Dev* 8: 9 - 22, 1994
- 79 Ponce-Castaneda MV, Lee MH, Latres E, Polyak K, Lacombe L, Montgomery
K, Mathew S, Krauter, K, Sheinfeld J, Massague J et al: p27kip1: chromosomal
mapping to 12p12-12p13.1 and absence of mutations in human tumors. *Cancer Res*
55: 1211 - 1214, 1995
- 80 Spirin KS, Simps JF, Takeuchi S, Kawamata N, Miller CW, Koeffler HP:
p27/kip1 mutation found in breast cancer. *Cancer Res* 56: 2400 - 2404, 1996
- 81 Orlow I, Iavarone A, Crider-Milner SJ, Bonilla F, Latres E, Lee MH, Gerald WE
Massague J, Weissman BE, Cordon-Cardo C: Cyclin-dependent kinase inhibitor
p57KIP2 in soft tissue sarcomas and Wilms' tumors. *Cancer Res* 56: 1219 - 1221,
1996
- 82 Mousses S, Ozcelik H, Lee PD, Malkin D, Bull SB, Andrulis IL: Two variants
of the CIP1/WAF1 gene occur together and are associated with human cancer. *Hum*
Mol Genet 4: 1089 -1092, 1995
- 83 Zhang P, Liegeois NJ, Wong C, Finegold M, Hou H, Thompson JC, Silverman
A, Harper JW, DePinho RA, Elledge SJ: Altered cell differentiation and
proliferation in mice lacking p57kip2 indicates a role in Beckwith-Wiedemann
syndrome. *Nature* 387: 151 - 158, 1997
- 84 Hall M, Peter G: Genetic alteration of cyclins, cyclin-dependent kinases and cdk

- inhibitors in human cancer. *Adv Cancer Res* 68: 67 , 1996
- 85 Barker FG, Chen P, Furman F, Aldape KD, Edwando MS, Israel MA: p16 deletion and mutation analysis in human brain tumors. *J Neurooncol* 31: 17 - 23, 1997
- 86 Segal RA, Goumenova LC, Kwon YK, Stiles CD, Pomeroy SL: Expression of neurotrophin receptor *trk C* is linked to a favorable outcome in medulloblastoma. *Proc Natl Acad Sci (USA)* 91: 12867 - 12871, 1994
- 87 Nakamura T, Takeshita I, Inamure T, Tashima T, Fukui M: Expression of β chain of platelet derived growth factor and proliferative activity of human brain tumors. *Neurol Med Chir (Tokyo)* 33: 205 -211, 1993
- 88 Jennings MT, Kaariainen IT, Gold L, Maciunas RJ, Comers PA: TGF beta 1 and TGF beta 2 are potential growth regulators for medulloblastomas, primitive neuroectodermal tumors and ependymomas: evidence in support of an autocrine hypothesis. *Hum Pathol* 25: 464 - 475, 1994
- 89 Stockhammer G, Manley GT, Johnson R, Rosenblum MK, Samid D, Lieberman FS: Inhibition of proliferation and induction of differentiation in medulloblastoma and astrocytoma derived cell lines with phenylacetate. *J Neurosurgery* 83: 672 - 681, 1995
- 90 Holgado-Madruga M, Emler DR, Moscatello DK, Godwin AK, Wong AJ: A Grb2 - associated docking protein in EGF and insulin receptor signaling. *Nature* 379: 560 - 564, 1996

CHAPTER 2

p53 gene mutation and mdm2 gene amplification are uncommon in medulloblastoma

Adekunle M. Adesina^{*,#}, Josephine Nalbantoglu^{*} and Webster K Cavenee^{+*}, Montreal Neurological Institute, McGill University, Montreal, Quebec and + Ludwig Institute for Cancer Research, University of California - San Diego, La Jolla, CA

ABSTRACT

Loss of heterozygosity is common for the short arm of chromosome 17 in medulloblastomas and putative medulloblastoma suppressor loci have been localized to 17p13. The colocalization of the p53 tumor suppressor gene to 17p13 raises the possibility that its mutant alleles may play a role in the malignant transformation of "medulloblasts". Mutations and deletions of the p53 gene have been described in many tumor types and in the germline of some individuals with the Li-Fraumeni syndrome, but reports on the status of the p53 gene and the mdm2 gene (a gene coding for a p53 associated protein reportedly amplified in human sarcomas) in medulloblastomas are few and an indication of their roles, if any, in the etiology of this important childhood tumor has yet to emerge. Here we have analysed polymerase chain reaction amplified products of exons 4-9 (95% of reported p53 mutations occur within this region) of the p53 gene in 9 medulloblastomas for potential mutations using the technique of single strand conformation polymorphism (SSCP) analysis and DNA sequencing. We found only one mutation, an A-T to T-A transversion involving the second base of codon 285 and resulting in the substitution of Valine for Glutamic acid. In none of eight of these tumors could amplification of the mdm2 gene be detected. These findings suggest that genetic events associated with the inactivation of p53 gene occur in

only a minor subset of medulloblastomas.

INTRODUCTION

Medulloblastomas account for 25% of childhood intracranial tumors. Histologically, most of these tumors are composed of sheets of undifferentiated cellular elements. A minority exhibit divergent differentiation with focal areas of rhabdomyosarcomatous, glial, neuronal and melanotic differentiation (1). This feature is shared with other central primitive neuroectodermal tumors (PNETs).

Cytogenetic and molecular studies have shown a frequent occurrence of isochromosome 17q with monosomy for 17p and trisomy for 17q (2) as well as loss of heterozygosity (LOH) for chromosomes 17p, 10 and 21 (3-5) in some medulloblastomas. However, studies directed at identifying patterns of oncogene amplification and / or overexpression (reviewed in refs. 6 and 7) have not demonstrated any alterations with prognostic value in medulloblastoma.

The LOH for 17p has been reported in about 45% of the small number of medulloblastomas examined (3-5), and has allowed a tentative localization of a putative medulloblastoma locus to 17p13 (3), although other analyses have suggested an additional locus telomeric to 17p13 (7,8). The co-localization of the 17p13 locus with that for p53 gene locus raises the possibility of a role of the p53 gene in the biology of medulloblastoma. Mutations and deletions of this p53 gene have been reported in many tumors of adults including lung and breast carcinoma, colorectal carcinoma, soft tissue sarcomas, and brain tumors (9-12). In the latter case, progression from low grade to high grade glioma has been shown to be associated with clonal expansion of p53 mutant cells (12).

The p53 gene codes for a 53kDa DNA binding protein (13) which regulates G₁/S phase transition of proliferating cells (14) by regulating the transcription of genes that control cell proliferation and cell cycle progression including inosine 5' monophosphate dehydrogenase (15) and cdk2 inhibitory protein (CIP1/WAF1) (16). This ability is lost in most mutant alleles (17) with the resultant loss of p53 mediated pauses needed to check unrepaired DNA damage; a prerequisite for preserving the integrity of the genome (18). The p53 gene product may autoregulate its own activity through regulation of the expression of the mdm2 gene (19) which codes for a p53 associated protein (20) which inactivates its activity. Amplification of mdm2 gene has been detected in sarcomas (20,21), and may occur as part of an amplicon including cdk4 gene and less frequently, the gli gene (22). Mdm2 gene amplification provides another mechanism for p53 inactivation in tumors that do not have p53 gene mutation.

The frequency of p53 gene mutation and mdm2 gene amplification appears to differ significantly among different solid childhood tumors, with a high frequency of p53 mutation (23,24) or mdm2 gene amplification (20,21) detected in rhabdomyosarcoma and osteogenic sarcoma and a low frequency of p53 mutation and / or mdm2 gene amplification in Wilm's tumor, neuroblastoma and hepatoblastoma (25). There have been only few reports on the analysis of p53 gene in a limited number of medulloblastomas (11,26,27) and the data suggest a low frequency of p53 gene mutations in these tumors. Here we report analyses which complement these data and extend the information to the mdm2 gene. We have analyzed the p53 gene in nine medulloblastomas and found only one tumor with a demonstrable p53 mutation. Furthermore, analysis of eight of these tumors showed no

demonstrable amplification of the *mdm2* gene. These data suggest that the p53 - *mdm2* interaction is not a major target for neoplastic transformation in medulloblastoma. They further emphasize the emerging picture of differing genetic alterations in tumors of adults and childhood.

MATERIALS AND METHODS

Single strand conformation polymorphism analysis (SSCP) and DNA sequencing. The tumors analysed here have been previously analysed for LOH on 17p with LOH on 17p13 shown in three out of the nine tumors (5). SSCP analysis based on the method of Orita et al (28) was done for exons 4-9 of the p53 gene. PCR was carried out under the following conditions: 10mM Tris-HCl, pH 8.3, 50mM KCl, 1.5mM MgCl₂, 0.01% gelatin, 200µM of each dNTP, 50pM of each exon specific forward and reverse primer, (exon 4 -5' TCCCCCTGCCGTCCCAAGC 3' (F), 5' CGTGCAAGTCACAGACTTGG 3' (R), exon 5 - 5' TACTCCCCTGCCC TCAACAA 3' (F), 5' CATCGCTATCTGAGCAGCGC 3' (R), exon 5-6 - 5' CACA CCCCCGCCCCG 3'(F), 5' ATGCCGCCCATGCAG 3'(R), exon 7 - 5' TGACTGTA CCACGATCC 3' (F), 5' TGTTCGGTCCCAGTAGATTA 3' (R), exon 8-9 - 5' TCCA TCCAGTGGTTTC 3' (F), 5' TGTTCGGTCCCAGTAGATT A 3' (R)), Taq DNA polymerase (Gibco BRL) at 2.5 units per reaction and 1µg of genomic DNA template. 0.5 µl of α ³²P dCTP was added to a 10 reaction master mix. Amplification was carried out in a Perkin Elmer Cetus thermocycler at 94°C for 2 min, 55-60°C for 2 min and 72°C for 3 min for 25 cycles. The amplified product was diluted 1:9 with water and an aliquot was mixed with an equal volume of gel loading solution (95% formamide, 0.1% bromophenol blue, 0.1% xylene cyanol), heat denatured at 95°C for 2 min, cooled on ice and electrophoresed on 6% non-denaturing polyacrylamide gel containing 10% glycerol at room temperature. Autoradiography was carried out for 12-24 hrs.

Asymmetric PCR product was obtained from genomic DNA using exon specific

primers (1:50 ratio) under similar conditions as described above. The product was cleaned with Centricon 100 and sequenced using the Sequenase version 2.0 protocol (United States Biochem. Corp., Cleveland, Ohio).

In addition, exons 4 - 9 of the p53 gene in the tumors that did not show conformational shift on SSCP analysis was amplified, cloned into M13 and single strands of this region were sequenced using the Sequenase protocol.

Southern Blotting. DNA was extracted from tumor samples using the proteinase K / phenol extraction method (29), digested with EcoR1, separated by electrophoresis in 1% agarose and transferred to nylon filters. Southern hybridization was carried out at 42°C in 6X SSC (1X SSC is 0.15M sodium chloride and 0.015M sodium citrate), 5X Denhardt's (1X Denhardt's is composed of 0.1g Ficoll (Type 400, Pharmacia) 0.1g polyvinylpyrrolidone, 0.1g Bovine serum albumin (Fraction V, Sigma) per liter), 1% SDS, and 50% formamide with 100ug/ml salmon sperm DNA and 2×10^6 cpm/ml probe labelled with α 32 P dCTP by random priming (31). After overnight hybridization, the blots were washed in 0.2X SSC/0.1% SDS at 65°C. The blots were subjected to autoradiography using Kodak films at -70°C with an intensifying screen. A 585bp mdm2 cDNA probe was generated by reverse transcription-polymerase chain reaction using published mdm2 specific oligonucleotide primers (21) and total cellular RNA from a normal human liver tissue as template. A probe for the chromosome 12p locus D12S2 was obtained from the American Type Culture Collection and used as an internal control for correction for chromosome 12 polysomies and

differential loading of lanes. The blots were also probed with a 534bp cdk4 cDNA probe, pK4-PCR (kindly provided by Dr T Look of St Jude Children's Hospital, Memphis, TN).

RESULTS

Single strand conformation polymorphism analysis (SSCP) and gene sequencing: SSCP analysis of exon 8-9 revealed a conformational shift in one of the tumors when compared with normal peripheral blood lymphocytes (Figure 1). Subsequent sequencing of exons 8 and 9 revealed an A-T to T-A transversion involving the second base of codon 285 and resulting in the substitution of Valine for Glutamic acid (Figure 2). This mutation lies within the conserved domain V of the p53 gene. Exons 4, 5, 6 and 7 revealed no demonstrable conformational shift in any of the tumors (data not shown). Furthermore, sequencing of M13 clones from the other tumors that did not demonstrate a conformational shift on the SSCP analysis did not reveal any mutations.

Analysis of mdm2 and cdk4 genes: Southern blot analysis of 5µg of Eco R1 digested genomic DNA revealed the expected bands for the mdm2 gene (21) (Figure 3). Correction for differential loading of the lanes and polysomies for chromosome 12 was done with the chromosome 12p specific DNA single copy gene, D12S2. Comparison of the band intensities by densitometry revealed no demonstrable amplification of the mdm2 gene in any of the tumors. Similarly, there was no demonstrable amplification of the cdk4 gene in these tumors (Figure 3).

Figure 1 SSCP analysis of exons 8 - 9 of the p53 gene in 6% non-denaturing polyacrylamide gel with 10% glycerol showing conformational shift in the single strands of tumor 8T. 2B and 8B represent PCR products from DNA isolated from peripheral blood of cases 2 and 8 and serve as controls. 8B-ND is a non-denatured double stranded DNA product .

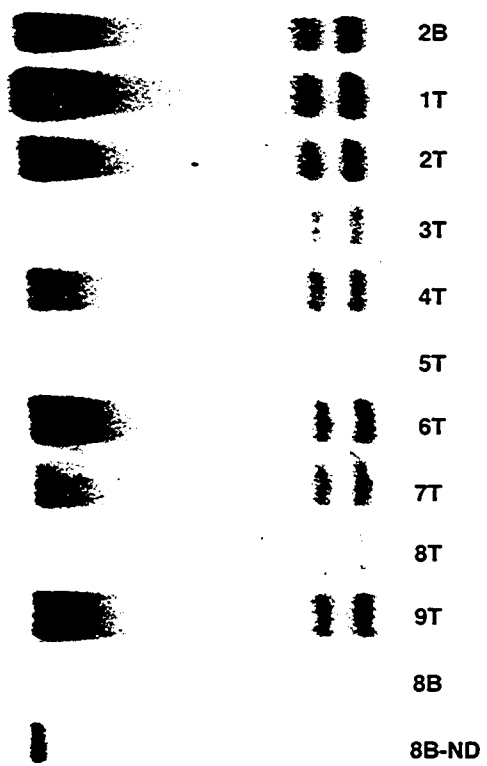

Figure 2 Sequencing of asymmetric PCR product of exons 8 - 9 of tumor 8T reveals an A-T to T-A transversion involving the second base of codon 285 resulting in the substitution of Valine for Glutamic acid.

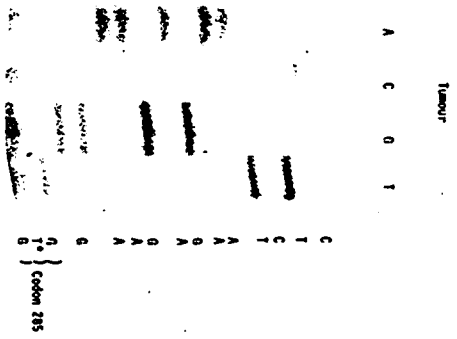
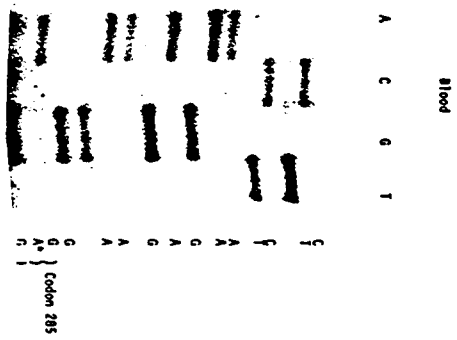
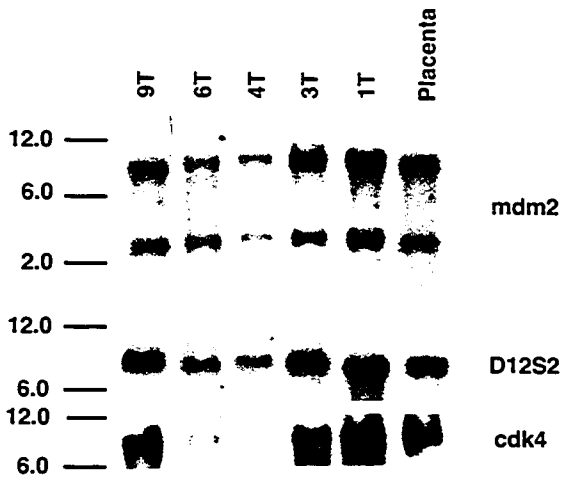

Figure 3 Southern blot analysis of Eco R1 digested DNA probed with mdm2 and cdk4 cDNA. Correction for differential loading and chromosome 12 polysomy with D12S2 shows no amplification of either the mdm2 gene or the cdk4 gene.



DISCUSSION

The analysis of exons 4 to 9 of the p53 gene has revealed a mutation in only one of the nine medulloblastomas. This mutation lies within the conserved domain V of the p53 gene and is due to an A-T to T-A transversion involving the second base of codon 285 resulting in the substitution of valine for glutamic acid. Mutations within this region have been reported to alter the conformation of the p53 protein product resulting in a change in the transcriptional activity and the half-life of such protein product (17). The tumors analysed here have been previously shown to have LOH on 17p in three out of the nine tumors (5) so that only one of these three has a demonstrable p53 mutation. The other six tumors retained both alleles for markers in 17p13. This is in sharp contrast to lung and glial brain tumors, among others (12,31), in which there is a high correlation between LOH on 17p and the presence of p53 mutation / deletion. These data complement and extend other reports which show p53 mutations in medulloblastoma / PNET tumors to range from none of 12 tumors and 1 of 3 cell lines (27), to 2 of 11 (26), 2 of 20 (7) 0 of 7 (8) and 1 of 9 (this study). Thus the overall incidence is about 8%, strengthening the suggestion of another tumor suppressor gene locus on 17p which might also play a role in the transformation and / or progression of medulloblastoma.

A review of the spectrum of p53 mutations in various tumors including malignant glial tumors and colorectal carcinoma shows a predominance of G:C to A:T transitions among these mutations. Most of these transitions occur at CpG islands and presumably result from the deamination of 5-methyl cytosine found at CpG sites (32). In addition,

p53 mutations in liver and lung are frequently dominated by G:C to T:A transversions, a finding suggesting selective targeting of some of these mutational hotspots by specific carcinogens such as benzpyrene through the formation of DNA adducts with guanine (33). Since most of the tumors with high prevalence of p53 mutation are adult tumors, selective targeting of the p53 mutational hotspots following prolonged exposure to environmental carcinogens probably plays a role in the mechanism of acquisition of p53 mutations by the transformed cells. In contrast, medulloblastoma is a childhood tumor sometimes seen in congenital form and rarely seen in adults. The low frequency of p53 mutations in medulloblastomas is consistent with the hypothesis that prolonged exposure to certain environmental mutagens may not play a major role in the etiopathogenesis of these childhood tumors.

Another mechanism of p53 inactivation is through the amplification of mdm2 gene, the protein product of which binds and inactivates wild type p53 (20). Amplification of this gene has been reported in some sarcomas (20,21) thus providing another mechanism for p53 inactivation in tumors that do not have p53 mutation. The role of this gene in the biology of medulloblastomas has not been reported. Here, we were not able to demonstrate amplification of the mdm2 gene in 8 of these tumors, thus excluding a major role for this gene in the biology of this set of medulloblastomas. Furthermore, we conclude that a lack of demonstrable cdk4 amplification makes a major role for the mdm2-cdk4-gli gene amplicon in the biology of these tumors unlikely.

References

- 1 Russell DS, Rubenstein LJ: Pathology of tumors of the central nervous system. 5th edition, pg 251-270, 1989
- 2 Bigner SH, Mark J, Friedman HS, Biegel JA, Bigner DD: Structural chromosomal abnormalities in human medulloblastoma. *Cancer Genet Cytogenet* 30: 91-101, 1988
- 3 Cogen PH, Daneshvar L, Metzger AK, Edwards MSB: Deletion mapping of the medulloblastoma locus on chromosome 17p. *Genomics* 8: 279-285, 1990
- 4 Thomas GA, Raffel C: Loss of heterozygosity on 6q, 16q and 17p in human central nervous system primitive neuroectodermal tumors. *Cancer Res* 51: 639-643, 1991
- 5 James CD, Ju H, Carbo E, Mikkelsen T, Ridderheim P, Cavenee WK, Collins VP: Loss of genetic information in central nervous system tumors common to children and young adults. *Genes Chromosomes and Cancer* 2: 94-102, 1990
- 6 Wasson JC, Saylor III RL, Zelter P, Friedman HS, Bigner SH, Burger PC, Bigner DD, Look AT, Douglas EC, Brodeur GM: Oncogene amplification in pediatric brain tumors. *Cancer Res* 50: 2987-2990, 1990
- 7 Cogen PH, Daneshvar L, Metzger AK, Duyk G, Edwards MSB, Sheffield VC: Involvement of multiple 17p loci in medulloblastoma tumorigenesis. *Am J Hum Genet* 50: 584-589, 1992
- 8 Biegel JA, Burk CD, Barr FG, Emanuel BS: Evidence for a 17p tumor related locus distinct from p53 in pediatric primitive neuroectodermal tumors. *Cancer*

Res 52: 3391-3395, 1992

- 9 Levine A, Momand J, Finlay CA: The p53 tumor suppressor gene. *Nature* 351: 453-456, 1991
- 10 Holstein M, Sidransky D, Vogelstein B, Harris CC: p53 mutations in human cancer. *Science* 253: 49-53, 1991
- 11 Mulligan LM, Matalashewski GJ, Scoble HJ, Cavenee WK: Mechanisms of p53 loss in human sarcomas *Proc Natl Acad Sci (USA)* 87: 5863-5867, 1990
- 12 Sidransky D, Mikkelsen T, Schehheimer K, Rosenblum M, Cavenee W, Vogelstein B: Clonal expansion of p53 mutant cells is associated with brain tumor progression. *Nature* 355: 846-847, 1992
- 13 Kern SE, Kinzler KW, Bruskin A, Jarosz D, Friedman P, Prives C, Vogelstein B: Identification of p53 as a sequence specific DNA binding protein. *Science* 252: 1708-1711, 1991
- 14 Mercer WE, Shields MT, Amin M, Sauve GJ, Appella E, Romano JW, and Ullrich SJ: Negative regulation in a glioblastoma tumor cell line that conditionally expresses human wild type p53. *Proc Natl Acad Sci (USA)* 87: 6166-6170, 1990
- 15 Sherley J: Guanine nucleotide biosynthesis is regulated by the cellular p53 concentration. *J Biol Chem.* 266: 24815-24828, 1991
- 16 El-Deiry WS, Tokino T, Velculescu VE, Levy DB, Parsons R, Trent JM, Lin D, Mercer WE, Kinzler KW, Vogelstein B: WAF1, a potential mediator of p53 tumor suppression. *Cell* 75: 817-825, 1993

- 17 Raycroft L, Schmidt JR, Yoas K, Hao M, Lozano G: Analysis of p53 mutants for transcriptional activity. *Mol Cell Biol* 11: 6067-6074, 1991
- 18 Yin Y, Tainsky MA, Bischoff FZ, Strong LC, Wahl GM: Wild type p53 restores cell cycle control and inhibits gene amplification in cells with mutant p53 alleles. *Cell* 70: 937-948, 1992
- 19 Barak Y, Juven T, Haffner R, Oren M: mdm2 expression is induced by wild type p53 activity. *EMBO J* 12: 461-468, 1993
- 20 Oliner JD, Kinzler KW, Meltzer PS, George DL, Vogelstein B: Amplification of a gene encoding a p53 associated protein in human sarcomas. *Nature* 358: 80-83, 1992
- 21 Ladanyi M, Cha C, Lewis R, Jhanwar SC, Huvos AG, Healey JH: mdm2 gene amplification in metastatic osteosarcoma. *Cancer Res* 53: 16-18, 1993
- 22 Khatib ZA, Matsushime H, Valentine M, Shapiro DN, Sherr CJ, Look AT: Coamplification of the *odk4* gene with *mdm2* and *gli* in human sarcomas. *Cancer Res* 53: 5535-5541, 1993
- 23 Felix CA, Chavez K C, Mitsudomi T, Nau MM, Tsokos M, Crouch GD, Nisen PD, Winick NJ, Helman LJ: Frequency and diversity of p53 mutations in childhood rhabdomyosarcoma. *Cancer Res* 52: 2243-2247, 1992
- 24 Ueda Y, Dockhorn-Dworniczak B, Blasius S, Mellin W, Wuisman P, Bocker W, Roesner A: Analysis of mutant p53 protein in osteosarcoma and other malignant and benign lesions of bone. *J Cancer Res Clin Oncol* 119: 172 - 178, 1993
- 25 Waber PG, Chen J, Nissen PD: Infrequency of *mdm2* gene amplification in

- pediatric solid tumors and lack of association with p53 mutations in adult squamous cell carcinomas. *Cancer Res* 53: 6028 - 6030, 1993
- 26 Oghaki H, Elbi RH, Wiestler OD, Vasargil MG, Newcomb EW, Kleihues P: p53 mutations in non astrocytic human brain tumors. *Cancer Res* 51: 6202-6205, 1991
- 27 Saylor III RL, Sidransky D, Friedman HS, Bigner SH, Bigner DD, Vogelstein B, Brodeur GM: Infrequent p53 gene mutations in medulloblastomas. *Cancer Res* 51: 4721-4723, 1991
- 28 Orita M, Suzuki Y, Sekiya T, Hayashi K: Rapid and sensitive detection of point mutation and DNA polymorphisms using the polymerase chain reaction. *Genomics* 5: 874-879, 1989
- 29 Sambrook J, Fritsch EF, Maniatis T: *Molecular cloning: a laboratory manual*. 2nd Edition, pg. 9.17 - 9.19, 1989
- 30 Feinberg AP, Vogelstein B: A technique for radiolabelling DNA restriction endonuclease fragments to high specific activity. *Anal Biochem* 137: 266-267, 1984
- 31 Takahashi T, Nau MM, Chiba I, Birrer MJ, Rosenberg RK, Vinocour M, Levitt M, Pass H, Gazdar AF, Minna JD: p53: A frequent target for genetic abnormalities in lung cancer. *Science* 246: 491-494, 1989
- 32 Rideout WM, Coetzee GA, Olumi AF, Jones PA: 5 methyl-cytosine as an endogenous mutagen in human LDL receptor and p53 genes. *Science* 249: 1288-1290, 1990

- 33 Pusieux A, Lim S, Groopman J, Ozurk M: Selective targeting of p53 gene mutational hotspots in human cancers by etiologically defined carcinogens. *Cancer Res* 51: 6185-6189, 1991

CHAPTER 3

Although we have demonstrated mutation of the p53 gene in a subset of medulloblastomas, a large proportion of these tumors do not appear to undergo malignant transformation via this pathogenetic mechanism. Similarly a p53-mdm2 interaction is not a method of p53 inactivation in these tumors. However, it is reasonable to presume that uncontrolled cell proliferation in medulloblastoma is a result of the deregulation of cell signaling and activation of mitogenic pathways. To understand the nature of this deregulation, a sequential analysis of all possible genes for mutations in medulloblastoma does not appear feasible. We hypothesized that genetic events that are important in the biology of medulloblastoma may be accompanied by the deregulation of the activity of a major and central second messenger signal transducer, such as protein kinase C which serves as a common converging point for signals transduced from the activation of tyrosine kinase receptors and G proteins. Such an analysis may provide an insight into the nature of the deregulation, if any, of PKC isoforms as second messenger transducers, a phenomenon which may be seen, even if the initiating genetic events differ.

Differential role for Protein kinase C - mediated signaling in the proliferation of medulloblastoma cell lines

Adekunle M Adesina**, Nora Dooley*, Voon-Wee Yong*, Josephine Nalbantogiu*, Department of Pathology, University of Oklahoma Health Sciences Center*, Oklahoma City, OK and Montreal Neurological Institute, McGill University*, Montreal, Quebec

ABSTRACT

Recent studies have implicated protein kinase C (PKC)-mediated signaling in the proliferation of gliomas. In this study, we have investigated the role of PKC mediated signaling in the proliferation of medulloblastoma cell lines DAOY, D283-Med and D341-Med. By Western blot analyses, conventional PKC (cPKC) α was detectable in DAOY only, while atypical PKC (aPKC) ζ was present in all three cell lines. cPKC β 1, β 11, γ , novel PKC (nPKC) δ , and ϵ were not detectable in all cell lines. Antisense oligonucleotides to PKC α , Calphostin C (a specific PKC inhibitor) and prolonged treatment with phorbol 12-myristate 13-acetate (PMA) with downregulation of cPKC α caused a decrease in proliferation in DAOY and no effect on D283-Med. Furthermore, PMA treatment was associated with upregulation of p21cip1 in DAOY. Since cPKC α is the only PMA responsive isoform in DAOY, this observation implicates the cPKC α isoform in the proliferation of DAOY but not in D283-Med. A comparison of DAOY and D283-Med showed a higher proliferation index in DAOY. In contrast, multiprobe ribonuclease protection assay revealed higher levels of p27 kip1 and p21 cip1 mRNA in D283-Med. These transcripts were barely detectable in untreated DAOY.

These observations indicate possible significant molecular heterogeneity among medulloblastoma cell lines with implications for differing biology among medulloblastoma cell lines and tumors.

INTRODUCTION

Medulloblastomas represent a major group of pediatric central nervous system tumors accounting for about 25% of childhood intracranial tumors. These tumors also occur in the adult population, but at a much lower frequency. While the histologic phenotypes of medulloblastoma have been well characterized with some associated significant prognostic implication (1), the major molecular determinants of malignant transformation and tumor biology in medulloblastoma and related primitive neuroectodermal tumors remain poorly characterized. To understand the biology of medulloblastoma, there is a need for an *in vitro* system where the role of some of the proteins involved as major and central second messengers in signaling, such as PKC, can be systematically analyzed.

PKC is a major signal transducer in the central nervous system (CNS) with important role in normal neuronal functioning, including long term potentiation and neurotransmitter release (2-4). PKC is a multigene family of serine/threonine kinases initially characterized by their response to Ca^{2+} , phospholipid and diacylglycerol (DAG) induced activation (5). There are eleven different isoforms currently identified. These include the Ca^{2+} dependent conventional PKC (cPKC) α , $\beta 1$, $\beta 11$ and γ which are activated by DAG, phorbol esters and phospholipids (reviewed in ref. 6,7), the Ca^{2+}

independent novel PKC (nPKC) δ , ϵ , η , θ , and μ which are also activated by DAG and phospholipids, and the Ca^{2+} independent atypical PKC (aPKC) ζ and λ which are activated by phospholipids only (reviewed in ref. 6,7).

PKC mediated signaling involves the classical pathway characterized by a series of phosphorylation and dephosphorylation events leading to the nuclear translocation of nuclear factor κB and the transcriptional activation of genes with the rel response element (8). More recent studies have implicated PKC also in the activation of the mitogen activated protein kinase (MAPK) pathway resulting in the activation of *c-jun* / *c-fos* (AP-1) heterodimer and activation of genes with the TPA response element, among others (9,10), with the ultimate modulation of cellular growth and response to mitogens. Specifically, in NIH 3T3 fibroblasts, cPKC α activates *raf-1* by direct phosphorylation, leading to activation of MAPK kinase (9). In CHO.10T1/2 cells, activation of MAPK depends on cPKC α , $\beta 1$ and γ but not PKC ϵ (10) while during angiotensin II induced vasoconstriction in vascular smooth muscle cells, the PKC mediated activation of MAP kinase is dependent on nPKC ϵ but not cPKC α (11). These examples illustrate the diversity in the function of PKC isoforms, depending on the tissue and the biological context in which they are activated.

Current observations continue to indicate a differential role for specific PKC isoforms in cell cycle regulation and more importantly, suggest that the overall observed effect of PKC activation is tissue-specific and isoform dependent. These effects range from cellular proliferation induced by PKC α overexpression in Swiss/3T3

fibroblasts (12) to the induction of terminal differentiation by PKC β in murine erythroleukemia cells (13) and growth suppression in human colon carcinoma cell lines by PKC β I (14). In addition, PKC α and / or δ have been observed to be involved in PKC mediated suppression of apoptosis by PMA in a plasmacytoma cell line (15) while activation of PKC by PMA inhibits apoptosis in HL-60 promyelocytic leukemia cells (16). Also, loss of PKC α expression correlates with the induction of differentiation in adipocytes (17) while the down regulation of PKC α partially abrogates the mitogenic response of Swiss 3T3 cells to bombesin and totally suppresses the mitogenic response of Swiss 3T3 cells to PMA activation (18). In rat C6 glioma cell lines, overexpression of PKC α correlates with the malignant phenotype and rat C6 glioma cell proliferation can be inhibited by treatment with antisense oligonucleotide to PKC α (19). Furthermore, the effect of phorbol ester stimulation of PKC is not only isoform dependent and tissue specific (20,21), the observed effects may also be cell cycle dependent in some cells, and are presumed to be partly related to a complex array of PKC-cyclin dependent kinase (cdk) signaling pathways which influence cell cycle control by inhibiting DNA synthesis when activated in the late G₁ phase, or potentiating growth factor-induced DNA synthesis when activated during early G₁ phase (22,23).

Cell cycle progression through G₁ phase following mitogen or growth factor stimulation is under the regulatory activity of cdk's including cdk4 / cdk6 and cdk2 which are themselves regulated by cyclins D and E respectively (24-28). Positive or negative regulation of cellular transit through G₁ to G₁/S phase by growth factors occurs either

through the activation or inhibition of the formation of active cyclin-cdk complexes respectively (29,30). This inhibition of cyclin-cdk complexes is effected by the upregulation of cyclin-cdk inhibitors including p21cip1 and p27kip1 which tightly bind to and inhibit the activity of cyclinD-cdk4 and cyclinE-cdk2 (31-35). For example, such an upregulation of cdk inhibitors including p21cip1, p27kip1 and p15^{INK4b} is seen following exposure of epithelial cells to transforming growth factor β and results in the inhibition of DNA synthesis and negative regulation of growth (34 -38). Although, both p21cip1 and p27kip1 function as cdk inhibitors, the specific pathways and conditions under which they function appear to differ. p21cip1 appears to function predominantly but not exclusively in pathways that monitor the cell's internal state including the detection of DNA damage which is p53 dependent (38-40), while p27kip1 is involved in pathways that sense both mitogenic and antiproliferative extrinsic signals (41). However, it is noteworthy that p21cip1 upregulation occurs via both p53 dependent (38-40) and p53 independent pathways (42).

We have chosen to study the medulloblastoma cell lines DAOY, D283-Med and D341-Med which represent some of the major phenotypic variants of medulloblastoma with DAOY having been derived from a desmoplastic medulloblastoma (43) and lacks neurofilament protein (NFP) expression while D283-Med and D341-Med were derived from classic medulloblastomas and both express NFP (44). The proliferation indices for these cell lines were first determined and correlated with the pattern of expression of cPKC isoforms, as well as cell cycle control genes. The effect of PKC modulation on cell growth in DAOY and D283-Med following prolonged treatment with PMA,

Calphostin C and antisense oligonucleotides to cPKC α was also assessed. Only DAOY showed inhibition of proliferation following the downregulation or inhibition of PKC α by these treatments. PKC-mediated signaling did not appear to play a significant role in the proliferation of D283-Med, attesting to the differential role played by these signaling pathways in the proliferation of medulloblastoma cell lines.

MATERIALS & METHODS

Cell culture, RNA extraction and reverse transcription/polymerase chain reaction (RT/PCR)

The medulloblastoma cell lines were obtained from the American Type Culture Collection, and grown in Minimum Essential Medium with Earle's salts and supplemented with non-essential amino acids and 10% fetal calf serum. The cells were grown until subconfluent, harvested and total RNA isolated using the guanidium isothiocyanate method of Chomczynski (45). The qualitative detection of cPKC transcripts was done by using the technique of reverse transcription and polymerase chain reaction (RT/PCR). PCR was carried out under the following conditions: 10mM Tris-HCl, pH 8.3, 50mM KCl, 1.5mM MgCl₂, 0.01% gelatin, 200µM of each dNTP, 50pM of each cPKC isoform specific forward and reverse primer, AMV reverse transcriptase (Gibco-BRL) at 2 units per reaction, Taq DNA polymerase (Gibco BRL) at 2.5 units per reaction and 1µg of total cellular RNA as template. 0.5 µl of α³²P dCTP was added to a 10 reaction master mix. Sequences for the cPKC isoform specific oligonucleotide primers have been previously published (46). Amplification was carried out in a Perkin Elmer Cetus thermocycler at 50°C for 10 min, followed by 94°C for 2 min, 60°C for 2 min and 72 C for 3 min for 25 cycles. 25µl of the product was electrophoresed on 8% non-denaturing polyacrylamide gel at room temperature. Autoradiography was carried out at room temperature for 1-3 hrs. Total cellular RNA from adult and fetal brains were analysed under the same conditions and served as

controls. Tubes with similar reaction mixture but containing β actin specific primers instead of the cPKC isoform primers were run concurrently with each experiment under the same conditions and they also served as controls.

Western blotting

For the detection of PKC isoform specific proteins, subconfluent cell cultures were harvested by trypsinization and centrifugation, followed by washes and final lysis in 2X SDS gel electrophoresis sample buffer (100mM Tris.HCl, pH 6.8, 200mM dithiothreitol, 4% SDS, 0.2% Bromophenol blue, 20% Glycerol) and heated in a boiling water bath for 10 minutes. 50 μ g or 100 μ g of whole cell extracts were electrophoresed in 12% SDS gels and transferred to nitrocellulose membranes. Immunoblot analysis was carried out with PKC isoform specific antibodies to PKC α , β (cross reactive with β 1 and β 11), γ , δ , ϵ and ζ at 2 μ g/ml (Gibco BRL). Detection of immunoreactivity was done with peroxidase conjugated secondary antibodies at 40mU/ml (units specified by the manufacturer) followed by chemiluminescence as per the manufacturer's protocol (Boehringer Mannheim).

For the determination of the effect of PKC modulation on cell proliferation, cells were plated into 60mm culture dishes and treated with antisense oligonucleotides to PKC α , PMA and Calphostin C and using appropriate controls (details below). Cells were harvested at 36 hours and 72 hours post-treatment. They were lysed in 2X SDS gel-loading buffer and heated in a boiling-water bath for 10 minutes. The samples were

processed for electrophoresis in 8% SDS-polyacrylamide gel. 50µg of total cellular protein was electrophoresed and transferred to nitrocellulose. Blocking was done with 5% non-fat dried milk, followed by incubation with rabbit polyclonal anti-PKC α antibody (Gibco, BRL) for 2 hours, rinsed 3x in PBS, incubated with biotinylated goat anti-rabbit antibody for 2 hours, rinsed 3x in PBS, followed by incubation with streptavidin horse-radish peroxidase conjugate for 30 minutes, rinsed 3x in 150mM NaCl, 50mM Tris.HCl (pH 7.5), followed by treatment with diaminobenzidine (DAB) (47).

Treatment with antisense oligonucleotide, phorbol 12-myristate 13-acetate (PMA), calphostin C, immunocytochemistry and proliferative index (PI) determination

Cells were plated on 12 multiwell plates (2×10^5) or 60mm dishes (1×10^6) and grown under similar conditions as stated above. In addition, 24 hours post-plating cells were treated with 5µM of HPLC-purified antisense phosphorothioate oligonucleotides to PKC α (5'-CCCGGGAAAACGTAGCC AT-3') (16) with 5µM of nonspecific oligonucleotide as control (5'-CCTGGAGAGCCAATCAG CCAG-3') (16). Preliminary experiments indicated that lower concentrations of antisense oligonucleotides were ineffective while higher concentrations (10µM) were cytotoxic. Other treatment groups consisted of 100ng of PMA with 4- α -PMA as control or 100 nM of Calphostin C with untreated cell plates serving as control. Antisense oligonucleotides were added every 36 hours. After 3 days of treatment, cells were pulsed with 10mM of Bromodeoxyuridine (BrdU) for 3 hours,

then rinsed 2x with PBS, fixed in 70% ethanol and air dried. It is to be noted that D283-Med grows predominantly in suspension with a few adherent cells. Therefore for this cell line, following pulsing with BrdU, the adherent cells were scraped with spatula and all cells aspirated into a centrifuge tube, followed by centrifugation for 5 minutes at 1200rpm, then 2x washes with PBS, with each wash followed by centrifugation. The cells were then spun onto slides using a cytospin. They were fixed in 70% ethanol and air dried. All fixed DAOY and D283-Med cells on plates or slides were subsequently processed in a similar fashion. They were then washed 3x in PBS, treated for 10min with 2N HCl, 3x washes with PBS, neutralized with 0.1M Sodium borate, pH 9.0, washed with PBS, treated with mouse monoclonal anti-BrdU 1:25 (Becton-Dickinson) and incubated at room temperature for 45 min. Subsequent treatments include, 3x washes in PBS, application of biotinylated universal secondary antibody (Research Genetics, Inc, Huntsville, AL) and incubation for 45 min, 3x washes in PBS, treatment for 15 min with streptavidin horse-radish peroxidase conjugate, 3x washes with PBS, followed by DAB for 5min, rinsed in PBS and stained with hematoxylin. The proliferative index is defined as a proportion of anti-BrdU positive cells obtained by random counting of five hundred cells in multiple fields. Treatments were done in triplicates and the mean values of the proliferative index of treatment groups were compared with those of controls using the *Student's t test*. Each experiment was repeated three times.

In situ Apoptosis detection

The detection of apoptosis, if any, in the DAOY and D283-Med cells following treatment with antisense PKC α oligonucleotides, PMA and Calphostin C was done using the Oncor ApopTag kit (Oncor, Gaithersburg, MD) following the manufacturer's protocol. This kit is based on the simple principle that morphologic apoptosis is a distinct physiologic process characterized by a multistage process of DNA fragmentation into multimers of about 180 bp nucleosomal units (seen as DNA laddering on agarose gels) with the generation of a multitude of new 3'OH DNA ends. These 3'OH DNA ends are tailed with Digoxigenin-dUTP in a reaction catalyzed by the enzyme terminal deoxynucleotidyl transferase (TdT). Detection is then done with peroxidase conjugated antidigoxigenin antibodies followed by DAB. The use of an *in situ* method has the unique advantage of being able to provide a single-cell sensitivity which may not be achievable with standard DNA agarose gel methods for detecting DNA laddering. Cells were fixed in 5% neutral buffered formalin, dried at 60°C and washed in PBS, followed by proteinase K digestion (20 μ g/ml) x 15 minutes, 4x washes in distilled water, quenching of endogenous peroxidase with 2% hydrogen peroxide, treatment with equilibration buffer, application of TdT/reaction buffer mix, followed by stop/wash buffer and then anti-digoxigenin-peroxidase, 3x washes in PBS and detection of positive reaction with DAB. The slides were counterstained with methyl green and mounted with permount. Positive controls were obtained by treating cells with DNase (1 μ g/ml) before

the TdT reaction step. Negative controls were obtained by omitting the TdT reaction step.

Multiprobe Riboquant RNase Protection Assay (RPA)

Quantitative RNase protection assay was done using the multiprobe riboquant RPA kit (Pharmingen, San Diego, CA) and following the manufacturer's protocol. Briefly, the RNA probe for the RPA was synthesized by in vitro RNA transcription using a multiprobe cocktail of DNA templates for cell cycle regulatory genes (hCC-1 and hCC-2). The probes were labelled by the incorporation of [α - 32 P]UTP during the probe synthesis. The reaction was terminated by adding DNase, and the free nucleotides separated from the synthesized radiolabelled RNA transcripts using phenol/chloroform:isoamyl alcohol. 2 μ g of total RNA from each of the treatment groups or cell line was hybridized overnight (16 hours) to the hCC-1 or hCC-2 cocktail of riboprobes (4×10^5 cpm/ μ l) at 37 degrees C. This was followed by RNase digestion, proteinase K treatment, extraction with phenol/chloroform and ethanol precipitation. Dried samples were dissolved in loading buffer and electrophoresed in 40 cm 6% sequencing gel. 4000 cpm/lane of the synthesized riboprobes served as size markers. The gels were dried and exposed overnight for autoradiography. The relative ratio of the band intensity for each specific gene to that of GAPDH which served as internal control was determined for each lane by densitometry. The HeLa cell RNA provided by the manufacturers served as positive control.

RESULTS

The proliferation indices of the medulloblastoma cell lines, DAOY, D283-Med and D341-Med were initially determined by the BrdU incorporation assay. This assay revealed significant differences in the proliferation of the three cell lines with DAOY > D283-Med > D341-Med (Figure 1, $p < 0.05$, *Students t test*). Although an earlier report may have indicated no significant difference in the doubling time of D283-Med and DAOY (44), we have consistently observed a significant difference in the proliferation indices of these cell lines.

To determine if differential expression of cPKC isoforms might account for these differences in proliferation index, RT-PCR for cPKC isoforms was performed. RT-PCR revealed detectable transcripts for cPKC α in DAOY and D283-Med. Although the RT-PCR was not designed to be quantitative, and being fully aware of the fact that quantitative estimates have significant limitations when applied to RT-PCR, we noted that the intensity of the bands obtained following RT-PCR for PKC α transcripts in DAOY is much stronger than that obtained for D283-Med (Figure 2). PKC β 1 transcripts were not detected in any of the three cell lines (Figure 2) while PKC β II transcripts were noted to be differentially expressed in the three cell lines (Figure 2). The lack of PKC β 1 expression in all the cell lines contrasts with its demonstrable expression in both the adult brain and the 16 week fetal brain controls. The detection of PKC α transcripts and the detection of β actin transcripts at relatively similar levels in all the cell lines confirm that the lack of detection of cPKC β 1 expression is not due to RNA

Figure 1 Comparison of the proliferation indices between DAOY, D283-Med and D341-Med. Proliferation indices were determined by incorporation of BrdU as described in materials and methods. Note that the proliferation index of DAOY is higher than that of D283-Med and D341-Med ($p < 0.05$ by *Student's t test*)

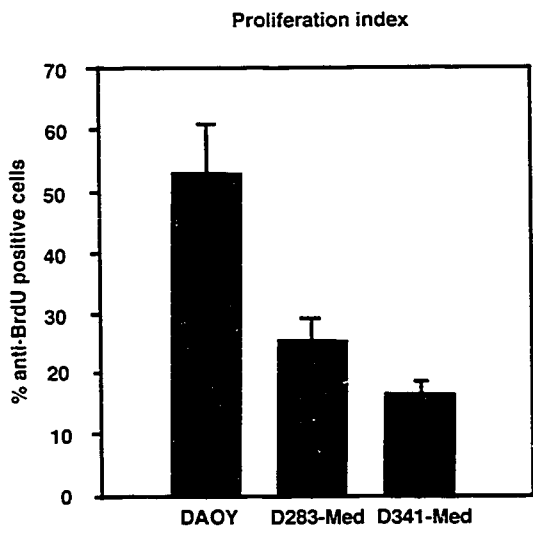
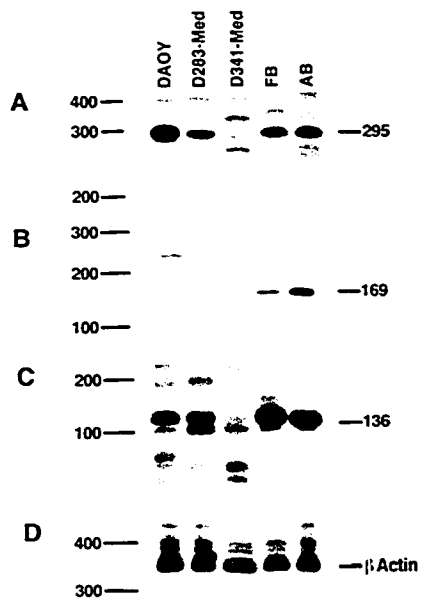

Figure 2 Expression of cPKC transcripts in medulloblastoma cell lines. Total cellular RNA was used as template in the RT/PCR protocol (25 cycles) with incorporation of [α - 32 P] dCTP, followed by electrophoresis on polyacrylamide gel and autoradiography as described in methods. (A) shows PKC α with qualitatively higher signal intensity in DAOY. (B) shows no detectable PKC β 1 transcripts in the three cell lines. (C) shows differential expression of PKC β 11 transcript in the three cell lines. (D) shows comparable levels of β actin transcript in all test samples, which were run under similar conditions as those for the PKC isoforms. FB = fetal brain, AD = adult brain. Line indicates the size of the specific band.



degradation (Figure 2). In addition, there were no demonstrable cPKC γ transcripts in any of the cell lines (data not shown). The expression of cPKC γ has been associated in the literature with mature neurons only (3). It is noteworthy, that no PKC α , β I and β II mRNA transcripts were detected in D341-Med (Figure 2).

To determine if there is a relationship between the presence of cPKC mRNA transcripts and the expression of the cPKC isoforms at the protein level, Western blot analyses were performed. Immunoblots revealed the expression of an approximately 80kDa cPKC α isoform protein in DAOY only (Figure 3A). A faint approximately 68kDa band is seen in D283-Med when reacted with the antibodies to PKC α . Since 80 kDa represents the expected size of the PKC α isoform, the smaller size band may represent a truncated or modified form of the PKC α protein. In addition, cPKC β 1, β 11 and γ , as well as nPKC δ and ϵ were not detectable in any of the cell lines (data not shown). aPKC ζ protein is expressed as a 75-80kDa doublet in DAOY and as a single 75kDa band in D283-Med and D341-Med (Figure 3B). The possible differential expression of cPKC α mRNA transcripts between DAOY and D283-Med as observed in the RT-PCR, is consistent with our demonstration of the 80kDa PKC α protein by immunoblot in DAOY only. In spite of the detection of cPKC β II mRNA transcripts in DAOY and D283-Med, cPKC β 11 proteins were not detected by immunoblotting and flow cytometry (data not shown) in the three cell lines.

To further define the role of PKC α in the biology of the medulloblastoma cell lines, DAOY and D283-Med cell lines were treated with antisense phosphorothioate

Figure 3 Expression of PKC isoforms in medulloblastoma cell lines. 50µg or 100µg of total cellular protein extract was electrophoresed in 12% SDS/Polyacrylamide gels. Immunoblots show the detection of (A) an 80kDa cPKC α protein in DAOY only. The faint band of 68kDa band in D383-Med may represent a truncated or modified form of this isoform. (B) aPKC ζ can be seen as a 75 - 80kDa doublet in DAOY and as a single band in D283-Med and D341-Med. cPKC β 1, β 11, γ and nPKC δ and ϵ were not detected (data not shown).

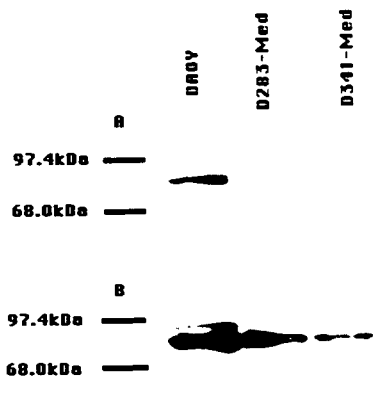

oligonucleotides (5 μ M) to PKC α or PMA at a concentration of 100ng/ml or Calphostin C at a concentration of 100nM. Appropriate non-specific antisense controls, 4- α -PMA controls and untreated control cells were set up respectively. There was a demonstrable 25 \pm 1.9% decrease in proliferation index (PI) following antisense treatment in DAOY (Figure 4A). Treatments with PMA and Calphostin C resulted in 36 \pm 2.4% and 35 \pm 2.1% decrease in proliferation, respectively and are statistically significant with $p < 0.05$. Morphologic changes were observed in the PMA treated group in which cells tended to become rounded with fewer cell processes when compared with the 4- α -PMA treated controls (Figure 5). This phenotypic effect of PMA has recently been attributed to PKC α modulation and linked to the inactivation of E cadherin in HT-29 human intestinal cells (48). No significant changes in proliferation index or phenotype were observed in D283-Med following similar treatment with antisense PKC α oligonucleotides, PMA and Calphostin C (Figure 4B).

Immunoblotting with anti-PKC α antibodies and densitometric scanning revealed a significant decrease in the level of PKC α protein following treatment of DAOY for 72 hours with PMA (approximately 47% reduction, Figure 6), antisense oligonucleotides to PKC α (approximately 21% reduction, Figure 6) and Calphostin C (approximately 48% reduction, Figure 6). Although, a reduction in PKC α protein is not necessary to observe the inhibitory effect of Calphostin C, we have consistently observed this effect of Calphostin C on PKC α protein level. No significant decrease in

Figure 4 Effect of down regulation of cPKC α on the proliferation index of medulloblastoma cell lines (A) DAOY (B) D283-Med following treatment with antisense PKC α oligonucleotide (column 3), PMA (column 1) Calphostin C (column 5) and corresponding antisense (column 4), 4- α -PMA (column 2) and untreated Calphostin C controls (columns 6) using the BrdU incorporation assay, indicates statistically significant difference in proliferation in DAOY only when compared to appropriate controls ($p < 0.05$).

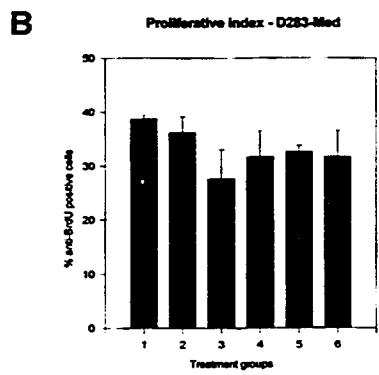
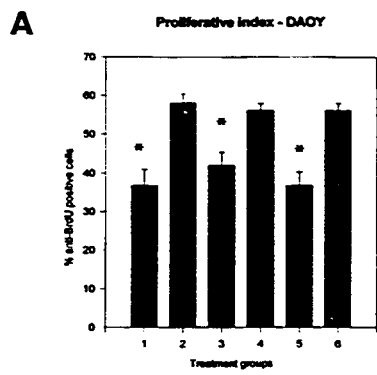
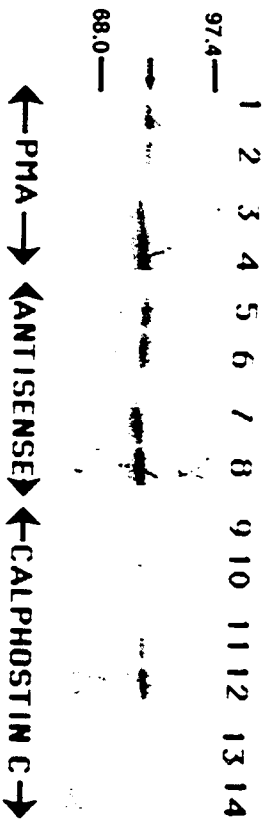

Figure 5 Effect of PMA treatment on the phenotype of the DAOY cell line following treatment with (A) 4- α -PMA and (B) PMA. Note the tendency for PMA treated cells to round up and to form less prominent processes.



Figure 6 Determination of PKC α protein levels following treatment of DAOY with PMA (lanes 1-4), antisense oligonucleotides (AS) to PKC α (lanes 5-8) and Calphostin C (lanes 9-14). Treatment was carried out for either 36 hours (lanes 1,2,5,6,9,10) or 72 hours (lanes 3,4,7,8,11-14). Appropriate controls were analyzed concurrently; 4- α - PMA (lanes 2 and 4); control oligonucleotide (lanes 6 and 8); vehicle control (lanes 10 and 12); control PKC α polypeptide block (lanes 13 and 14). Note the decrease in PKC α protein at 72 hours following treatment with PMA (lane 3 compared with lane 4), following treatment with antisense to PKC α (lane 7 compared with lane 8) and following treatment with Calphostin C (lane 11 compared with lane 12).

Treatment	AS	PMA	Calphostin C
Reduction of PKC α protein (%)	21	47	48



PKC α protein was detected in similarly treated DAOY cells when harvested at 36 hours post treatment. The decrease in the level of cPKC α protein after 72 hours of treatment is consistent with the observed decrease in proliferation index in DAOY and also offers an explanation for the modest decrease in proliferation observed after cPKC α antisense treatment. These experiments were carried out in the presence of serum. The presence of other growth factors that are able to activate alternate mitogenic pathways independent of PKC may account for these modest decreases in proliferation index. Carrying out these experiments in the presence of serum is probably a more realistic simulation of the *in vivo* state in which these tumors are continually exposed to the mitogenic effect of serum growth factors. The decrease in proliferation index in DAOY following PKC modulation, may reflect the relative role of this signaling pathway in the proliferation of DAOY.

Furthermore, we were interested in determining the effect of PKC modulation on the pattern of expression of cell cycle related genes in DAOY. Using the multiprobe riboquant RPA with probes for cell cycle related genes, we noted no significant alteration in the expression of p18, p27kip1, p57kip2, cdk1, cdk2, cdk3, cdk4, pRB, and p53 in the antisense PKC α , PMA and Calphostin C treated groups (Figures 7 and 8). However, a 6 to 7 fold upregulation of the expression of the mRNA transcript for p21cip1 was noted following prolonged treatment with PMA for 36 hours and 72 hours (Figure 7). The upregulation of p21cip1 was not seen in the antisense PKC α and Calphostin C treated cells. Therefore, this upregulation may not be due to PKC α

Figure 7 Analysis of transcripts for cell cycle regulatory genes after modulation of PKC expression in DAOY cell line. Multiprobe RPA analysis was carried out with the multiprobe cocktail hCC-2. Treatment of cells was as follows: antisense (AS) PKC α (1), antisense control (2), PMA(3), 4- α -PMA (4), Calphostin C (5), Calphostin C control (6). Note the upregulation of p21cip1 in the PMA treated cells (lane3) compared with the 4- α -PMA control (lane 4). HeLa cell line served as control.

Treatment	AS	PMA	Calphostin C
Upregulation of p21cip1	-	6 - 7x	-

(The numbers were derived from the densitometric scanning of several different autoradiographic exposures)

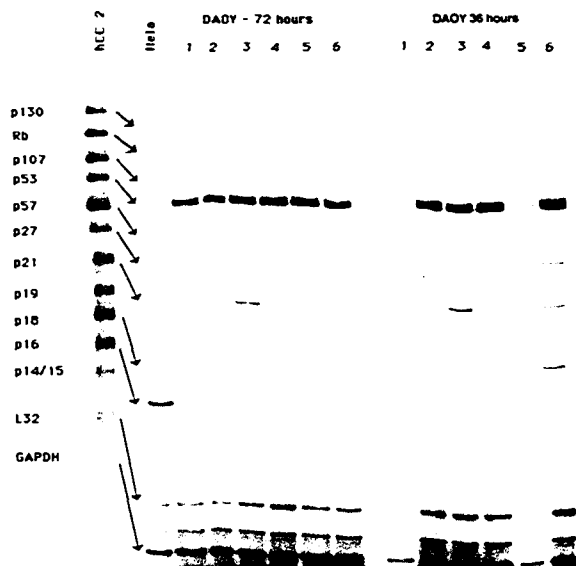
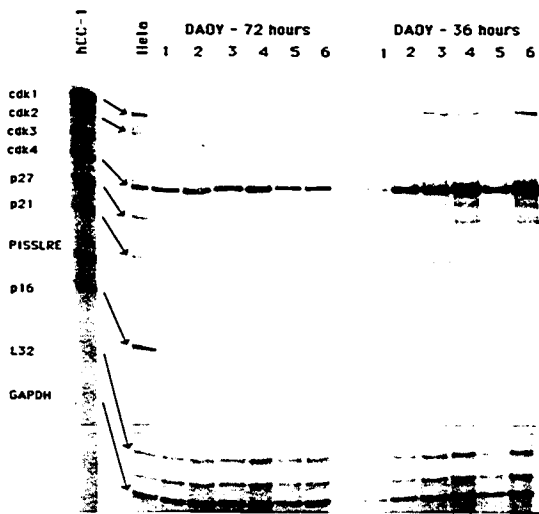

Figure 8 Analysis of transcripts for cell cycle regulatory genes after modulation of PKC expression in DAOY cell line. Multiprobe RPA analysis was carried out with the multiprobe cocktail hCC-1. Treatment of cells was as follows: antisense PKC α (1), antisense control (2), PMA(3), 4- α -PMA (4), Calphostin C (5), Calphostin C control (6). Note the upregulation of p21cip1 in the PMA treated cells (lane3) compared with the 4- α -PMA control (lane 4). HeLa cell line served as control.



inhibition but related to other PMA specific effects. Since DAOY is known to contain a mutant p53 (49), it is reasonable to presume that the upregulation of p21cip1 observed in this cell line represents a p53 independent modulation of p21cip1 expression. Analysis of the PMA treated DAOY cells for apoptosis revealed that this upregulation of p21cip1 did not induce apoptosis as assessed with the Oncor apoptag (TUNEL assay) kit.

Following our observation of a barely detectable and relatively low level of p21cip1 expression in the untreated DAOY, we compared the pattern of expression of these cell cycle related genes in untreated DAOY and D283-Med using the multiprobe riboquant RPA kit. This analysis confirmed the earlier observation of barely detectable levels of p21cip1 and p27kip1 in DAOY (Figure 9). In contrast, p21cip1 mRNA transcripts and more significantly p27kip1 mRNA transcripts were expressed at higher levels in D283-Med. Densitometric analysis showed about 14 and 7 fold higher levels of p27kip1 and p21cip1, respectively, in D283-Med when compared with DAOY. This differential expression of p21cip1 and p27kip1 between DAOY and D283-Med is consistent with the observed lower proliferation rate in D283-Med.

Figure 9 Analysis of transcripts for cell cycle regulatory genes in untreated cell lines DAOY and D283-Med with the multiprobe cocktail hCC-1 (A) and hCC-2 (B). Despite the unequal loading between DAOY and D283-Med lanes, it is evident that p21cip1 and p27kip1 transcripts are barely detectable in DAOY in comparison to the much higher levels of these two transcripts in D283-Med. HeLa cell line served as control.

Ratio of DAOY:D341-Med

p21cip1	1:14
p27kip1	1:7

(The numbers were derived from the densitometric scanning of several different autoradiographic exposures)

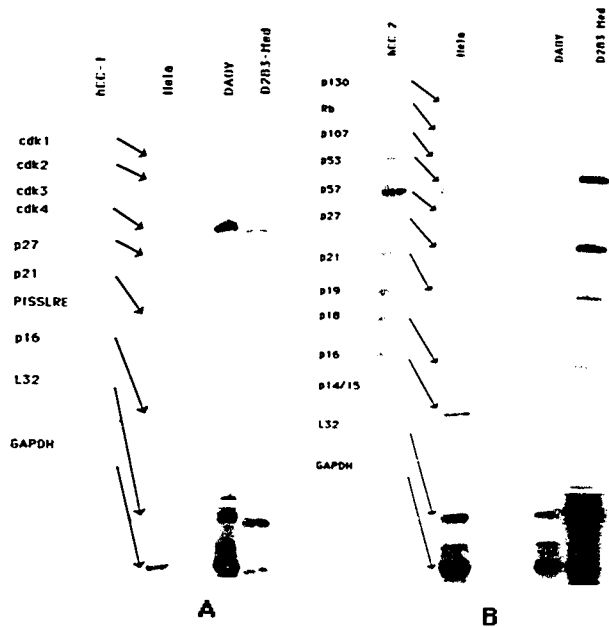

DISCUSSION

Current hypotheses based on immunochemical characterization of primitive cells of the external granular layer and the germinal matrix of the posterior medullary velum have implicated the immature cells of the external granular layer as the precursor cells of desmoplastic medulloblastoma while incompletely migrated precursor cells either originating in the rhombic lip or in the germinal matrix of the posterior medullary velum have been proposed as the precursors of classic medulloblastoma and related PNETS (50,51). The superficial proliferative and the deep zone of premigratory cells of the external granular layer, as well as the intermediate zone cells of the ventricular germinal matrix have been reported to be composed of cells showing among others, immunoreactivity for p75NGFR (51). In contrast, cells in the proliferative zone of the ventricular germinal matrix are notably negative for p75NGFR (51). The DAOY cell line was originally developed from a desmoplastic medulloblastoma (42,49) while the D283-Med and D341-Med cell lines were obtained from classic medulloblastomas (44). Using immunocytochemical methods, we have been able to demonstrate the expression of neurotrophin receptors *trkB*, *trkC* and may be even *trkA* in the DAOY cell line (unpublished observations). None of these receptors were detected in D283-Med. Similar observations confirming the expression of *trkB* and *trkC* transcripts in DAOY only, was also recently reported by another group (52). These findings suggest a similarity between DAOY and external granular layer cells on the one hand and a similarity between D283-Med cell line and proliferative ventricular zone cells on the other.

PKC is present as a major signal transducer in the CNS with widespread distribution in various neuronal cell populations (3). In the medulloblastoma cell lines, cPKC α protein is seen in DAOY only while aPKC ζ is present in the three cell lines. cPKC $\beta 1$, $\beta 11$, γ , as well as nPKC δ , and ϵ were not present in any of the three cell lines. Therefore, the predominant PMA responsive PKC isoform that we have been able to demonstrate in DAOY is cPKC α . Furthermore, treatments which resulted in downregulation of cPKC α had a growth inhibitory effect on DAOY cells. The presence of this isoform is consistent with the higher proliferative index in DAOY when compared with D283-Med and D341-Med. In contrast, D283-Med and D341-Med do not express any PMA responsive PKC isoform including cPKC α protein and is consistent with the observed lack of growth inhibition following the prolonged treatment of D283-Med with antisense PKC α oligonucleotides, PMA and the PKC specific inhibitor, Calphostin C. Some reports have found a higher proliferation index as well as decreased dependence on external growth factors in systems in which the cPKC α has been overexpressed (12). Our observations implicate cPKC α isoform in the proliferation of DAOY and is consistent with a role for PKC α in the biology of a subset of medulloblastoma cell lines and possibly medulloblastoma tumors. The lack of effect of these treatments on D283-Med is indicative of molecular heterogeneity among medulloblastoma cell lines with implications for differing biology among medulloblastoma cell lines and tumors.

A modulation of the pattern of PKC isoform expression has been associated with the amplification of N-myc in neuroblastoma cell lines (53) and in rat fibroblasts

transfected with ras, src and fos oncogenes (54). It is not clear what oncogene/s account for the upregulation of cPKC α in DAOY. However, a recent report indicates a demonstrable p53 mutation in the DAOY cell line (49).

In these medulloblastoma cell lines, there is a distinct lack of demonstrable cPKC β 1 transcripts despite the presence of cPKC β 11 transcripts. Both isoforms are known to be obtained from a single mRNA by alternative splicing (6). While studies on C3H.10T1/2 cells have suggested a transforming role for the cPKC β isoform (55,56), transfection of the cPKC β isoform into the murine erythroleukemia cells (13) as well as an assay of the pattern of expression of cPKC β in HL-60 promyelocytic leukemia variant cells resistant to the induction of cell differentiation (57) have implicated the cPKC β isoform as a prerequisite for the ability to induce terminal differentiation in these cell lines. In addition, overexpression of the cPKC β 1 isoform in human colon cancer cells has been associated with growth inhibition and tumor suppressor function (14).

In rat cerebellar cortex, the cPKC β 1 isoform is present mainly in the internal granular cell layer while the cPKC β 11 is predominantly in the molecular layer (58). The internal granular layer is composed of a differentiated neuronal cell population which developmentally are derived by migration of cells from the undifferentiated external granular cell layer. It is currently unknown if cPKC β 1 plays a role in the induction of terminal neuronal differentiation, however, its expression in the internal granular neurons coincides with terminal differentiation in this layer in the developing CNS (58). It is tempting to speculate on a terminal differentiation role for this isoform in neuronal

development as has been demonstrated in murine erythroleukemia cells. Such a deduction will have to await the results of transfection or transgenic studies. At this juncture, one can only speculate on the possible relationship between our finding of a lack of expression of cPKC β 1 and its possible role in the lack of terminal differentiation in these medulloblastoma cell lines. The lack of expression of this isoform is clearly not due to the absence of the gene that codes for it, since the cPKC β II isoform which is obtained by alternative splicing of the primary transcript is demonstrable in these cell lines. A current study indicates that a switch in the alternative splicing of the PKC β mRNA transcripts from β I to β II may be influenced by exposure to extrinsic signals such as insulin (59). We hypothesize that a dysregulation of cPKC β I expression plays a significant role in the lack of commitment of medulloblastoma cell lines to induced terminal differentiation.

An alternative explanation is to simply regard the lack of cPKC β 1 expression as a feature of the immaturity of these cells by presuming that cPKC β 1 expression is a mature neuronal phenotype. Although cPKC β 1 may not directly induce cell differentiation, in other cell systems (57) it appears to prime the cell, possibly by inducing the expression or activation of specific genes required for the cell to respond to differentiation inducing stimuli (13,57). Similarly, the medulloblastoma cell lines do not express PKC δ , an isoform that has been associated with neural differentiation in PC12 cells (60). In CHO, Daudi Burkitt's lymphoma cells and myeloid precursor cells, phorbol ester-induced cell growth arrest or differentiation has been shown to be

mediated by cPKC α and δ (7,20,21). More recent studies implicating PKC-cdk interaction in the positive and negative regulation of DNA synthesis depending on whether the cell is in late or early G₁ phase at the time of PKC activation (21) support the hypothesis that the pattern of PKC isoform expression is important in determining the pattern of cell response.

It is noteworthy that while the basal level of expression of p21cip1 and p27kip1 is very low in DAOY, the slower growing D283-Med expresses higher levels of these cdk inhibitors. In gastric carcinoma cells, p53 mutation is associated with very low or undetectable levels of p21cip1 mRNA compared with very high levels of p21cip1 in cells with wild type p53 (61). We hypothesize that the presence of p53 mutation results in the barely detectable levels of p21cip1 in DAOY compared to D283-Med which has a wild type p53 (48). Furthermore, in this study, prolonged PMA treatment of DAOY is accompanied by upregulation of p21cip1 mRNA possibly via p53 independent pathways (42) involving the activation of p21cip1 expression. The p21cip1 gene promoter region is known to contain the TPA response element, AP2 (62).

It has been reported that cell cycle withdrawal in postmitotic neurons involves cyclin dependent kinases and specifically, during mouse neurogenesis, cortical postmitotic neurons have been shown to accumulate high levels of p27 kip1 compared with their progenitor neuroblasts (63). The higher level of p27 kip1 expression in D283-Med is consistent with the reported expression of NFP in this cell line in contrast to DAOY which does not express NFP (44). Our immunohistochemical analysis of medulloblastoma tumors for these cdk inhibitors revealed a relationship between the

detection of p27kip1 expression and the focal loss of proliferation activity with the development of neuronal differentiation (64). Furthermore, in mice, targeted disruption of p27kip1 is associated with enlargement of all tissues, with increase in the number of cells leading to the suggestion that p27kip1 deficiency may cause a cell autonomous defect resulting in enhanced proliferation in response to mitogens (65). These observations suggest that a dysregulation of the cdk inhibitors may also underlie the proliferation of medulloblastomas. An understanding of the mechanism/s underlying this dysregulation of the expression of cell cycle regulatory genes is, therefore, critical to our understanding of the biology of medulloblastoma. Cell cycle control is the focal point of all mitogenic and proliferative pathways and may provide the key to developing appropriate gene therapies for specific tumors including medulloblastoma.

References

- 1 Russell DS, Rubinstein LJ: Pathology of tumors of the central nervous system 5th edition, Williams & Wilkins, 251 - 270, 1989
- 2 Ben-Ari Y, Aniksztejn L, Biegestovki P: Protein kinase C modulation of NMDA currents: an important link for LTP induction. Trends Neurosci 15: 333 - 339, 1992
- 3 Saito N, Kikkawa U, Nishizuka Y, Tanaka C: Distribution of protein kinase C - like immunoreactive neurons in rat brain. J Neuroscience 8: 369 - 382, 1988
- 4 Koda Y, Kobayashi H, Mizki T, Okazaki M, Uezono Y, Yanagihara N, Wa A, Izumi F: Protein kinase C subtypes in tissues derived from neural crest. Brain Res 518: 334 - 336, 1990
- 5 Nishizuka Y: Intracellular signaling by hydrolysis of phospholipids and activation of protein kinase C. Science 258: 607 - 613, 1992
- 6 Nishizuka Y: The molecular heterogeneity of protein kinase C and its implications for cellular regulation. Nature 334:661 -665, 1988
- 7 Nishizuka Y: Protein kinase C and lipid signaling for sustained cellular responses. FASEB J 9: 484-496, 1995
- 8 Ghosh S, Baltimore D: Activation in vitro of NF-kappa B by phosphorylation of its inhibitor I kappa B. Nature 344: 678 - 682, 1990
- 9 Kolch W, Heidecker G, Kochs G, Hummel R, Vahidi H, Mischak H, Finkenzeller G, Marme D, Rapp UR: Protein Kinase C alpha activates RAF-1 by direct phosphorylation. Nature 364: 249 - 252, 1993

- 10 Young SW, Dickens M, Tavaré JM: Activation of mitogen-activated protein kinase by protein kinase C isotypes alpha, beta 1 and gamma but not epsilon. *FEBS Lett* 384: 181 -184, 1996
- 11 Malarkey K, McLees A, Paul A, Gould GW, Plein R: The role of protein kinase C in activation and termination of mitogen-activated protein kinase activity in angiotensin II - stimulated rat aortic smooth muscle cells. *Cellular Signaling* 8: 123- 129, 1996
- 12 Eldar H, Zisman Y, Ullrich A, Livneh E: Overexpression of protein kinase C α subtype in Swiss/3T3 fibroblasts causes loss of both high and low affinity receptor numbers for epidermal growth factor. *J Biol Chem* 265: 13290 - 13296, 1990
- 13 Melloni E, Ponremoli S, Sparastove B, Patrone M, Grossi F, Marks PA, Rifkin RA: Introduction of the β isozyme of protein kinase C accelerates induced differentiation of murine erythroleukemia cells. *Proc Natl Acad Sci (USA)* 87, 4417 - 4420, 1990
- 14 Choi P, Tchou-Wong K, Weinstein IB: Overexpression of protein kinase C in HT 29 colon cancer cells causes growth inhibition and tumor suppression. *Mol Cell Biol* 10: 4650 - 4657, 1990
- 15 Romanova LY, Alexandrov IA, Schwab G, Hilbert DM, Mushinski JF, Nordan RP: Mechanism of apoptosis suppression by phorbol ester in IL-6 starved

- murine plasmacytoma: role of PKC modulation and cell cycle. *Biochemistry* 35: 9900 - 9996, 1996
- 16 Zhu WH, Loh TT: Differential effects of phorbol esters on apoptosis in HL-60 promyelocytic leukemia cells. *Biochem Pharmacol* 51: 1229 - 1236, 1996
- 17 McGowan K, DeVente J, Carey JO, Ways DK, Pekala PH: Protein kinase C isoform expression during the differentiation of 3T3-L1 preadipocytes: loss of protein kinase C - alpha isoform correlates with loss of phorbol 12-myristate 13-acetate activation of nuclear factor kappa B and acquisition of the adipocyte phenotype. *J Cell Physiol* 167: 113- 120, 1996
- 18 Florin-Christensen J, Florin-Christensen M, Meinardi E, Calle R: Diversity of roles of protein kinase C alpha in the proliferation of Swiss 3T3 cells. *Biochem J* 315: 513 - 516, 1996
- 19 Baltuch GH, Dooley NP, Rostworowski KM, Villemure J-G, Yong VW: Protein kinase C isoform α overexpression in C6 glioma cells and its role in cell proliferation. *J Neuro-Oncol* 24: 241 - 250, 1995
- 20 Mischak H, Pierce JH, Goodnight J, Kananietz MG, Blumberg PM, Mushinski JF: Phorbol ester-induced myeloid differentiation is mediated by protein kinase C $-\alpha$ and $-\delta$ and not by protein kinase C $-\beta$ II, $-\epsilon$, $-\zeta$, η . *J Biol Chem* 268: 20110-20115, 1993
- 21 Watanabe T, Ono Y, Taniyama Y, Hazama K, Igarashi K, Ogita K, Kikkawa U, Nishizuka Y: Cell division arrest induced by phorbol ester in CHO

- overexpressing protein kinase C δ subspecies. Proc Natl Acad Sci (USA) 89: 10159-10163, 1992
- 22 Zhou W, Takuwa N, Kumada M, Takuwa Y: Protein kinase C-mediated bidirectional regulation of DNA synthesis, RB protein phosphorylation and cyclin dependent kinases in human vascular endothelial cells. J Biol Chem 268:23041-23048, 1993
- 23 Faria M, Armelin HA: Antagonistic actions of phorbol ester in mammalian $G_0 \rightarrow G_1 \rightarrow S$ cell cycle transition. Cell Growth Differ 7: 75 - 81, 1996
- 24 Dulic V, Lees E, Reed SI: Association of human cyclin E with a periodic G_1/S phase protein kinase. Science 257: 1958 1961, 1992
- 25 Koff A, Giordano A, Desai D, Yamashita K, Harper JW, Elledge S, Nishimoto T, Morgan DO, Franza BR, Roberts JM: Formation and activation of a cyclin E-cdk2 complex during G_1 phase of the human cell cycle. Science 257: 1689 - 1694, 1992
- 26 Matsuchime H, Quelle DE, Shurtleff SA, Shibuya M, Sherr CJ, Kato J-Y: D-type cyclin-dependent kinase activity in mammalian cells. Mol Cell Biol 14: 2066 -2076, 1994
- 27 Meyerson M, Harlow E: Identification of G_1 kinase activity for cdk6, a novel cyclin D partner. Mol Cell Biol 14: 2077 - 2086, 1994

- 28 Retnisky D, Gossen M, Bujard H, Reed SI: Acceleration of the G₁/S phase transition by expression of cyclins D1 and E with an inducible system. *Mol Cell Biol* 14: 1669 - 1679, 1994
- 29 Ewen ME, Sluss HK, Whitehouse LL, Livingston DM: TGF β inhibition of cdk4 kinase is linked to cell cycle arrest. *Cell* 74: 1009 - 1020, 1993
- 30 Koff A, Ohtsuki M, Polyak K, Roberts JM, Massague J: Negative regulation of G₁ in mammalian cells: inhibition of cyclin E-dependent kinase by TGF- β . *Science* 260: 536 -539, 1993
- 31 Xiong Y, Hannon GJ, Zhand H, Caso D, Kobayashi R, Beach D: p21 is a universal inhibitor of cyclin kinases. *Nature* 366: 701 - 704, 1993
- 32 Xiong Y, Xiang H, Beach D: D type cyclins associate with multiple protein kinases and the DNA replication and repair factor PCNA. *Cell* 71: 505 -5143, 1992
- 33 Harper JW, Adami GR, Wei N, Keymars K, Elledge SJ: The cdk interacting protein cip1 is a potent inhibitor of G₁ cyclin dependent kinases. *Cell* 75: 805 - 816, 1993
- 34 Polyak K, Kato J-Y, Solomon MJ, Sherr CJ, Massague J, Roberts JM, Koff A: p27^{kip1}, a cyclin-cdk inhibitor links transforming growth factor - β and contact inhibition to cell cycle arrest. *Genes & Dev* 8: 9 - 22, 1994

- 35 Polyak K, Lee M-H, Erdjument-Bromage H, Koff A, Roberts JM, Tempst P, Massague J: Cloning of p27kip1 , a cyclin-dependent kinase inhibitor and a potential mediator of extracellular antimitogenic signals. *Cell* 78: 59 - 66, 1994
- 36 Reynisdottir I, Polyak K, Iavarone A, Massague J: Kip/cip and INK4 cdk inhibitors cooperate to induce cell cycle arrest in response to TGF β . *Genes & Dev* 9:1831 - 1845, 1995
- 37 Hannon GS, Beach D: p15INK4B is a potential effector of TGF β -induced cell cycle arrest. *Nature* 371: 257 - 261, 1994
- 38 Ewen ME: p53 dependent response of cdk4 synthesis in transforming growth factor - β - induced G1 cell cycle arrest. *J Lab Clin Med* 128: 355 - 360, 1996
- 39 El-Deiry WS, Tokino T, Velculescu VE, Levy DB, Parsons R, Trent JM, Lin D, Mercer WE, Kinzler KW, Vogelstein B: Waf1, a potential mediator of p53 tumor suppressor. *Cell* 75: 817 - 825, 1993
- 40 Dulic V, Kaufman WK, Wilson SJ, Tlsty TD, Lees E, Elledge SJ, Reed SI: p53 dependent inhibition of cyclin dependent kinase activity in human fibroblast during radiation induced G1 arrest. *Cell* 76: 1013 - 1023, 1994
- 41 Ravitz MJ, Yan S, Dolce C, Kinniburgh AJ, Wenner CE: Differential regulation of p27 and cyclin D1 by TGF β and RGF in C3H.10T1/2 mouse fibroblasts. *J Cellular Physiol* 168: 510 - 520, 1996

- 42 Fuse T, Yamada K, Kato T, Nakanishi M: Heat shock-mediated cell cycle arrest is accompanied by induction of p21 cki. *Biochem Biophys Res Commun* 225: 759 - 763, 1996
- 43 Jacobsen PF, Jenkyn DJ, Papadimitriou JM: Establishment of a human medulloblastoma cell line and its heterotransplantation into nude mice. *J Neuropathol Exp Neurol* 44, 472-485, 1985
- 44 He X, Med MS, Skapek SX, Wikstrand CJ, Friedman HS, Trojanowski JQ, Kemshead JT, Coakham HB, Bigner SH, Bigner DD: Phenotypic analysis of four human medulloblastoma cell lines and transplantable xenografts. *J Neuropathol Exp Neurol* 48, 48-68, 1989
- 45 Chomczynski P, Sacchi N: Single step method of RNA isolation by acid guanidinium thiocyanate-phenol-chloroform extraction *Anal Biochem* 162: 156-159, 1987
- 46 Yong VW, Dooley NP, Noble PG: Protein kinase C in cultured adult human oligodendrocytes: a potential role for isoform alpha as a mediator of process outgrowth. *J Neurosci Res* 39: 83 - 86, 1994
- 47 Sambrook J, Fritsch EF, Maniatis T: *Molecular cloning, a laboratory manual*, 2nd edition, Cold Spring Harbor Laboratory Press, 1989, 18.62-18.75
- 48 Llosas MD, Batlle E, Coll O, Skoudy A, Fabre M, Garcia de Herreras A: Evidence for a role of conventional protein kinase C alpha in the control of homotypic contacts and cell scattering of HT-29 human intestinal cells. *Biochem J* 315: 1949 - 1964, 1996

- 49 Saylor III RL, Sidransky D, Friedman HS, Bigner SH, Bigner DD, Vogelstein B, Brodeur GM: Infrequent p53 gene mutations in medulloblastomas. *Cancer Research* 51: 4721-4723, 1991
- 50 Kasetos CD, Frankfurter A, Christakos S, Mancall EL, Vlachos IN, Ulrich H: Differential localization of class III β tubulin isotype and calbindin-D_{28k} defines distinct neuronal types in the developing human cerebellar cortex. *J Neuropath Exp Neurol* 52: 655-666, 1993
- 51 Yachnis AT, Rorke LB, Lee V M-Y, Trojanowski JQ: Expression of neuronal and glial polypeptides during histogenesis of the human cerebellar cortex including observation on the dentate nucleus. *J Comp Neurol* 334, 356-369, 1993
- 52 Segal RA, Goumnerova LC, Kwon YK, Stiles CD, Pomeroy SL: Expression of neurotrophin receptor trk C is linked to a favorable outcome in medulloblastoma. *Proc Natl Acad Sci (USA)* 91, 12867-12871, 1994
- 53 Bernards R: N-myc disrupts protein kinase C- mediated signal transduction in neuroblastoma. *EMBO J* 10: 1119-1125, 1991
- 54 Borner C, Guadagno SN, Hsiao WW-L, Fabbro D, Barr M, Weinstein IB: Expression of four protein kinase C isoforms in rat fibroblasts. *J Biol Chem* 267: 12900 - 12910, 1992

- 55 Hsiao W-LW, Housey GM, Johnson MD, Weinstein IB: Cells that overproduce protein kinase C are more susceptible to transformation by an activated *H-ras* oncogene. *Mol Cell Biol* 9: 2641 - 2647, 1989
- 56 Krauss RS, Housey GM, Johnson MD, Weinstein IB: Disturbances in growth control and gene expression in a C3H.10T1/2 cell line that stably overexpresses protein kinase C. *Oncogene* 4: 991 - 998, 1989
- 57 Nishikawa M, Komada F, Uemura Y, Hidaka H, Shirakawa S: Decreased expression of type II protein kinase C in HL-60 variant cells resistant to induction of cell differentiation by phorbol ester. *Cancer Res* 50: 621 - 626, 1990
- 58 Sposi NM, Bottero L, Cossu G, Russo G, Testa U, Peschle C: Expression of protein kinase C genes during ontogenic development of central nervous system. *Mol Cell Biol* 9: 2284-2288, 1989
- 59 Chalfant CE, Mischak H, Watson JE, Winkler BC, Goodnight J, Farese RV, Cooper DR: Regulation of alternative splicing of protein kinase C beta by insulin. *J Biol Chem* 270: 13326 - 13332, 1995
- 60 O'Driscoll KR, Teng KK, Fabbro D, Greene LA, Weinstein IB: Selective translocation of protein kinase C- δ in PC12 cells during nerve growth factor induced neuritogenesis. *Mol Cell Biol* 6: 449 - 458, 1995
- 61 Akama Y, Yasui W, Kuniyasu H, Hokoziaki H, Akagi M, Tahara H, Ishikawa T, Tahara E: Genetic status and expression of the cyclin-dependent kinase

inhibitors in human gastric carcinoma cell lines. *Jpn J Cancer Res* 87: 824 - 830, 1996

- 62 Zeng YX, Somasundaram K, El-Deiry WS: AP2 inhibits cancer cell growth and activates p21 waf1/cip1 expression. *Nature Genet* 15: 78 - 82, 1997
- 63 Lee MH, Nikolic M, Baptista CA, Lai E, Isai LH, Massague J: The brain specific activator p35 allows cdk5 to escape inhibition by p27kip1 in neurons. *Proc Natl Acad Sci (U S A)* 93: 3259 - 3263, 1996
- 64 Adesina AM, Dunn T, Nalbantoglu J: The pattern of p27kip1 expression shows a correlation between focal inhibition of proliferation and differentiation in medulloblastoma. (Submitted)
- 65 Fer ML, Rivkin M, Tasch M, Porter P, Crow CE, Firpo E, Polyak K, Tsai LH, Broudy V, Perlmutter RM, Kaushansky K, Roberts JM: A syndrome of multiorgan hyperplasia with features of gigantism, tumorigenesis and female sterility in p27(kip1)-deficient mice. *Cell* 85: 733 - 744, 1996

CHAPTER 4

The riboquant multiprobe RPA analysis of medulloblastoma cell lines, DAOY and D283-Med showed a significant difference in the expression of cdk inhibitors p21cip1 and p27kip1. This differential expression also correlates with significant differences in the proliferation of these two cell lines, thus suggesting a role for the pattern of expression of these cdk inhibitors in the proliferation of these cell lines. We hypothesized that uncontrolled cellular proliferation in medulloblastoma is related to the dysregulation of the expression of cdk inhibitors, p21cip1 and p27kip1. While the cell lines provided *in vitro* evidence supporting this hypothesis, we did not know if this finding has any relevance to medulloblastomas *in vivo*. Therefore, to determine if the pattern of expression of p21cip1 and p27kip1 played a role in the biology of medulloblastoma, we used immunohistochemical methods to detect their expression in medulloblastoma tumors.

The pattern of p27kip1 expression shows a relationship with focal inhibition of proliferation and differentiation in medulloblastoma

Adekunle M Adesina+*, Dunn T* and Nabantoglu J*, Department of Pathology, University of Oklahoma Health Sciences Center*, Oklahoma City, OK and Montreal Neurological Institute, McGill University*, Montreal, Quebec

ABSTRACT

p27kip1 and p21cip1 are cyclin-dependent kinase (cdk) inhibitors with critical roles in the control of cell cycle progression. Accumulation of p27kip1 in postmitotic neurons is a major component of neurogenesis. We investigated p27kip1 and p21cip1 immunoreactivity in medulloblastoma tumors. We found an inverse relationship between p27kip1 expression and proliferation (MIB1). Focal islands of neuroblastic or glial differentiation expressed high levels of p27kip1. In contrast, the undifferentiated highly proliferative population of tumor cells showed no detectable p27kip1 expression. In addition, there was no detectable p21cip1 expression in any of the medulloblastomas. There was no relationship between the detection of p53 protein and lack of p21cip1 expression. Similarly, positivity for p53 protein did not show any relationship with proliferation or apoptotic index. The low level of apoptosis in these tumors was not associated with the expression of Bcl2. These findings suggest a role for p27kip1 in cell cycle control in medulloblastoma. Since, p21cip1 and p27kip1 are often coexpressed along with other INK4 family of cdk inhibitors during the induction of cell differentiation and are synergistic in their effect, a deregulation of the coordinate

expression of p21cip1 and p27kip1 may underly the lack of complete differentiation in medulloblastoma.

INTRODUCTION

Regulation of cellular transit through G₁ to G₁/S by growth factors occurs either through the activation or inhibition of the formation of active cyclin-cdk complexes (1,2). The inhibition of cyclin-cdk complexes is effected by the upregulation of cyclin-cdk inhibitors including p21cip1 and p27kip1 among others. These tightly bind to and inhibit the activity of cyclin-cdk4 and cyclin E-cdk2 (3-7). While p21cip1 appears to function predominantly in pathways that monitor the cell's internal state, including the detection of DNA damage, which is p53 dependent (8-10), p27kip1 is involved in pathways that sense both mitogenic and antiproliferative extrinsic signals (11).

Exit from the cell cycle is a prerequisite for the onset of terminal differentiation. The induction of p21cip1, p27kip1 and the INK4 family of proteins appears to play a significant role in this cell cycle exit (12). For example, the permanent arrest of cell division and the induction of differentiation are associated with p21cip1 expression in embryonic and adult mouse tissues (13). p21cip1 expression has also been observed to increase with cessation of cell division and differentiation in diverse epithelia cells including stomach, tongue, cervix and hair follicle (14) as well as in adenomas and adenocarcinomas of the colon (15). While a close inverse relationship exists between p21cip1 expression and proliferation in many tissues, detection of p21cip1 has been found to be rare in some human adult tissues including lung, kidney, thyroid, pancreas,

and liver (16), thus suggesting that there might be variation in the expression of this cdk inhibitor among different human tissues. During mouse neurogenesis, p27kip1 cdk inhibitor appears to accumulate at high levels in postmitotic neurons compared with their progenitor neuroblasts (17). This growth inhibitory role of p27kip1 is further illustrated by the spontaneous development of pituitary tumors and multiorgan hyperplasia in the p27kip1 deficient mice (18).

Mutations and genetic alterations involving p27kip1, p21cip1 and p57kip2 are infrequent in human tumors, suggesting that this mechanism is not the preferred method of dysregulation of expression of these cdk inhibitors (19-22). However, recent studies have reported a correlation between p53 mutation and low expression of p21cip1 in gastric carcinomas and colonic adenocarcinomas (15,23); an observation consistent with the demonstrated role of p53 in the regulation of p21cip1 expression (9,10). It is noteworthy that p21cip1 upregulation occurs via p53 dependent and p53 independent pathways (24).

Medulloblastomas represent a major group of malignant childhood central nervous system tumors in which there is very little understanding of the major molecular determinants of cell transformation and biology. We and others have reported a low frequency of p53 mutation in medulloblastomas (25,26). However, we have found a relationship between p53 status and the expression of cdk inhibitor, p21cip1, in medulloblastoma cell lines DAOY and D283-Med. We also observed a relationship between the expression of p27kip1 mRNA and a lower proliferation rate in the medulloblastoma cell line D283-Med when compared with DAOY which has a higher

proliferation index and very low levels of p27kip1 mRNA (27). These observations suggest a possible significant role for cdk inhibitors p21cip1 and p27kip1 in the biology of medulloblastoma.

In this study, we have used immunohistochemical methods to analyze medulloblastoma tumors for the expression of cdk inhibitors p27kip1 and p21cip1 and determined the relationship between their pattern of expression and the expression of p53, proliferation index, apoptosis and the expression of the anti-apoptosis gene, Bcl2.

MATERIALS AND METHODS

A total of 14 medulloblastomas diagnosed at the University Hospitals, Oklahoma City, OK were available for this study. Patients had undergone surgery for brain tumors between 1987 and 1994. The histologic slides were reviewed and the original diagnosis of medulloblastoma confirmed.

Imunohistochemistry

Serial sections of 5µm thick sections of paraffin embedded tissue were deparaffinized in xylene, hydrated through 100% to 70% ethanol, followed by antigen retrieval by microwaving for a total of 15 min in 10mM citrate buffer. Slides were rinsed in automation buffer (Research Genetics, Huntsville, Alabama) 3x, followed by protein blocker (Research Genetics, Huntsville, Alabama) for 15 minutes, 3x washes [all washes are done with automation buffer (Research Genetics)], followed by incubation with primary monoclonal antibody to each one of the following antigens (i) p53, - DO-7 antibody which reacts with mutant and wild type p53 (DAKO, Carpenteria, CA) at 1:50 dilution at 4°C overnight, (ii) Bcl2 (DAKO) at 1:40 dilution for 1 hour at 37°C, (iii) p21 (Pharmlingen, San Diego, CA) at 20 µg/ml overnight at 4°C, (iv) p27 (Pharmlingen, San Diego, CA) at 5 µg/ml overnight at 4°C and (v) Ki-67 (MIB1) (Immunotech Inc, Westbrook, ME) at 1:40 dilution at 37°C for 1 hour, (vi) synaptophysin (Biogenex, SanRaymon, CA) at room temperature (RT) for 25 minutes and (vii) GFAP (Cell Marque Corp, Austin,Tx) at RT for 25 minutes. Following incubation with primary antibody, slides are washed 3x, incubated with biotinylated universal secondary antibody

(Research Genetics, Huntsville, Alabama), washed 3x, incubated with strepavidin horse-radish peroxidase x 15 minutes and treated with diaminobenzidine (DAB) or 3-amino-9-ethylcarbazole for 5 minutes. Slides are dehydrated and mounted with permount. Positive controls include, tonsil for p21cip1 and p27kip1, a breast carcinoma known to express p53 for p53, a follicular lymphoma for Bcl2 and brain for synaptophysin/GFAP. Negative controls were obtained by using non-specific mouse serum in place of primary antibody or by omitting primary antibodies. The positivity index is defined as the percentage of positive cells seen by counting 500 cells in the most positive areas of the tissue. Analyses of each of the immunostains were done "blindly."

***In situ* Apoptosis detection**

The detection of apoptosis, if any, in the medulloblastomas was done using the Oncor ApopTag kit (Oncor, Gaithersburg, MD) and following the manufacturer's protocol. This kit is a TUNEL assay kit based on the simple principle that morphologic apoptosis is a distinct physiologic process characterized by a multistage process of DNA fragmentation into multimers of about 180 bp nucleosomal units (seen as DNA laddering on agarose gels) with the generation of a multitude of new 3'OH DNA ends. These 3'OH DNA ends are tailed with Digoxigenin-dUTP in a reaction catalyzed by the enzyme terminal deoxynucleotidyl transferase (TdT). Detection is then done with peroxidase conjugated antidigoxigenin antibodies followed by DAB (28). The use of an *in situ* method has the unique advantage of being able to provide a single-cell sensitivity which may not be achievable with standard DNA agarose gel methods for detecting

DNA laddering. Briefly, 5µm thick sections of paraffin embedded tissue were deparaffinized in xylene, hydrated through 100% to 70% ethanol, followed by proteinase K digestion (20µg/ml) x 15 minutes, 4x washes in distilled water, quenching of endogenous peroxidase with 2% hydrogen peroxide, treatment with equilibration buffer, application of TdT/reaction buffer mix, followed by stop/wash buffer and then anti-digoxigenin-peroxidase, 3x washes 3x in PBS and detection of positive reaction with DAB. Sections were counterstained with methyl green and mounted with permount. Positive controls were obtained by treating tissue with DNase (1µg/ml) before the TdT reaction step. Negative controls were obtained by omitting the TdT reaction step. The apoptosis index is defined as the percentage of positive cells seen by counting 500 cells in the most positive areas of the tissue.

RESULTS

Out of the 14 tumors analysed, 5 showed features of desmoplastic medulloblastoma with multifocal islands of pale staining tumor cells with a distinct slightly more fibrillary stroma randomly distributed within these islands (Figure 1A). These islands occasionally showed positivity for synaptophysin indicating the formation of synaptic vesicles and consistent with neuroblastic differentiation (Figure 1B).

Immunohistochemical analysis for p53 protein using DO-7 antibody revealed positive nuclear staining in > 10% of the cells in 2 (two) cases with 14.6% and 16% positivity, respectively (Figure 2C), <5% of the cells in 4 (four) tumors, one of which showed 3% positivity while the other (3) three showed only rare to few positive cells. Since the antibody, DO-7, detects both mutant and wild type p53, the immunohistochemical detection of p53 may not necessarily indicate the presence of p53 mutation. However, the detection of p53 positive staining suggests a deregulation of p53 expression since normal p53 protein has a short half life and is not usually detectable in tissues (29). There was no relationship between nuclear positivity for p53 and proliferation index.

p21cip1 (Figure 2A) expression and Bcl2 expression (Figure 2B) were not demonstrable in any of the tumors. The analyses of the tumors for apoptosis revealed 1 (one) tumor with an apoptotic index of 5% (Figure 2D), 2 (two) tumors with a score of 2% , 8 (eight) tumors with a score of < or = 1% and 3 (three) tumors with no detectable apoptosis. There was no demonstrable inverse relationship between p53 positive nuclear staining (Figure 2C) and the apoptotic index. The low level of apoptosis

is consistent with the high proliferation index observed in these tumors (mean proliferation index = 28.46 +/- 8.6%) (Table 1).

p27kip1 expression was detected in 8 (eight) of the tumors. A comparison of the mean proliferation index for the p27kip1 positive and negative tumors revealed no statistically significant difference. However, further analysis of the pattern of positivity for p27kip1 in the 5 (five) tumors with the focal islands of neuronal or glial differentiation revealed an inverse relationship between positivity for p27kip1 and positivity for the proliferation antigen, Ki-67 (MIB-1). The differentiating islands showed strong positivity for p27kip1 and low proliferation index with few cells positive for Ki-67, consistent with the withdrawal of these cells from the proliferation pool and the cell cycle (Figure 3A,C) . In contrast, the tumor cells in the non-differentiating areas showed very few cells positive for p27kip1 and a high proliferation index (Figure 3B,D), thereby implicating p27kip1 in the arrest of cell cycle progression during the differentiation of medulloblastoma cells.

The ages at diagnosis and the length of survival of the patients is as shown in Table 1. Correlation of survival with pattern of immunoreactivity is limited by both the number of cases and the duration of follow up. Despite this limitation, there is a trend towards longer survival in p27kip1 positive patients. Three of the five patients who were p27kip1 negative died within 13 months of diagnosis. Of the nine patients who were p27kip1 positive, three died within 16 months of diagnosis. It is noteworthy that in two of these patients (cases #8 and 13), their tumors also had 14.6% and 3% of cells positive for p53 protein respectively.

TABLE 1

Results of immunohistochemical analysis of medulloblastomas.

Cases	Age (yrs)	p27	p53	ApopTag	MIB1	Survival (months)
1	4.5	0	0	0	28.2	13(D)
2	7	0*	0	0	25	54(A)
3	0.25	0	16	1	34	2(D)
4	4	0	<1	<1	26	104(A)
5	7	weak*	0	5	17.8	47(A)
6	8	1	0	1	18	16(D)
7	2.5	0	<1	1	35	8(D)
8	4	1	14.6	0	44.4	6.5(D)
9	8	50	0	2	32	48(A)
10	5	30*	<1	2	40.6	36(A)
11	14	29	0	<1	29	46(A)
12	4	25*	0	1	26	61(A)
13	5	24*	3	<1	29	10(D)
14	15	19	0	1	13.4	81(A)

Figures represent percentage of positive cells in each tumor, A=alive, D=dead

*desmoplastic medulloblastomas with pale islands of neuroblastic differentiation

Figure 1 Section of desmoplastic medulloblastoma showing (A) pale islands with slightly more fibrillary stroma and a slight streaming pattern, (Hematoxylin & Eosin) and (B) synaptophysin immunoreactivity in these differentiating islands and is consistent with neuroblastic differentiation (Magnification x 400).

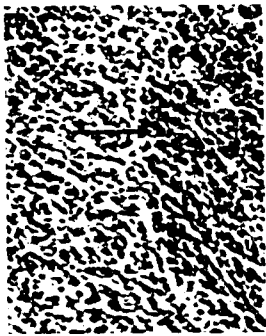
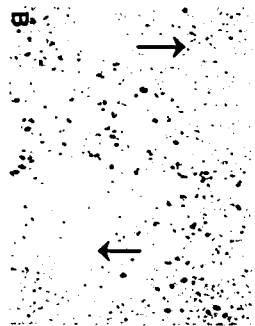
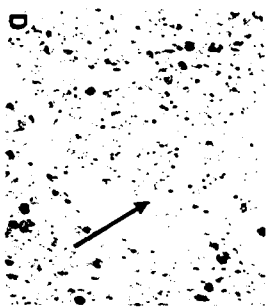
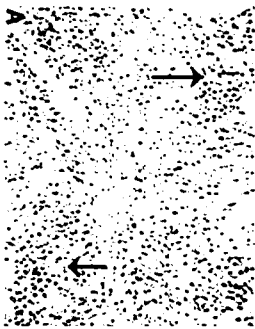
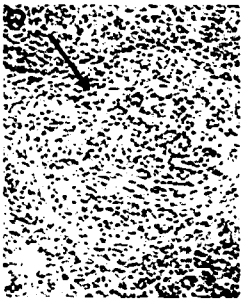

Figure 2 Immunohistochemical analysis of medulloblastoma. Sections show lack of immunoreactivity for (A) p21cip1 and (B) Bcl2 while there is some (C) p53 nuclear immunoreactivity and (D) infrequent apoptosis as detected by TUNEL assay in this medulloblastoma (Magnification A, C, D x 400, B x 200)



Figure 3 Inverse staining of desmoplastic medulloblastomas for (A,C) p27kip1 and (B,D) Ki-67. Immunoreactivity for p27kip1 is seen predominantly in the differentiating islands (arrows). In contrast, immunoreactivity for Ki-67 (MIB1) is infrequent in the differentiating p27kip1 positive islands (arrows) but frequent in the non-differentiating p27kip1 negative population of cells (Magnification: A, B x 400, C & D x 200).



DISCUSSION

We have investigated p27kip1 and p21cip1 immunoreactivity in medulloblastoma tumors and found an inverse relationship between p27kip1 expression and proliferation (MIB1). Focal islands of neuroblastic differentiation expressed high levels of p27kip1. In contrast, the undifferentiated highly proliferative population of tumor cells showed no detectable p27kip1 expression. In addition, there was no detectable p21cip1 expression in any of the medulloblastomas. There was no relationship between the detection of p53 protein and lack of p21cip1 expression. Similarly, positivity for p53 protein did not show any relationship with proliferation or apoptotic index. The low level of apoptosis in these tumors was not associated with the expression of Bcl2.

We and others have reported a low frequency (8%) of detectable p53 mutation in medulloblastoma (25,26). However, in this study, we have noted that 6 out of 14 tumors showed immunohistochemically demonstrable p53. 4 of these 6 positive tumors had only rare to few positive cells which nonetheless showed strong and specific nuclear positivity. The detection of p53 protein would suggest abnormal elongation of the half life of this protein resulting from a dysregulation of its expression due to either a mutant p53 gene or a deregulation of genes that control p53 activity (30). Although we do not see any relationship between p53 expression and proliferation index or apoptosis in this set of medulloblastomas, we observed a relatively short survival in the 3 cases with a population of p53 positive cells equal to or greater than 3%. Our observation of a relatively short survival in these few p53 positive patients may suggest a prognostic significance for p53 overexpression in these tumors. It is currently unclear if p53

overexpression may confer a poor prognosis, independent of p27kip1 expression in medulloblastoma. One cannot but speculate that there might be a currently unclear biological relevance for the immunohistochemically detectable p53 protein in these tumors

There was a lack of detectable p21cip1 expression in these tumors, particularly in areas of neuroblastic differentiation. Although p21cip1 expression can be p53 dependent (9,10), its expression via p53 independent pathways has been well documented and may occur along with the induction of p27kip1 expression (12). For example, during the vitamin D3 induced differentiation of the myelomonocytic cell line U937, the transcriptional activation of p21cip1 is associated with the increased expression of p27kip1 (12). In this experimental system, the strongest expression of the cell surface differentiation markers occurred when both p27kip1 and p21cip1 were co-transfected in this myeloid cell line, thus suggesting a synergistic role and possible requirement for the expression of multiple cell cycle inhibitors to obtain complete differentiation. Our observation with these medulloblastomas in which only focal and limited differentiation is seen in association with the expression of p27kip1 only is consistent with such reports. However, whether the co-expression of multiple cdk inhibitors is required to ensure complete differentiation in medulloblastoma awaits future studies.

Apoptosis is the mechanism by which excess primitive stem cells in the subependymal germinal matrix are eliminated during neurogenesis and subsequent maturation of the central nervous system (31). It has been postulated that

medulloblastomas and related primitive neuroectodermal tumors, may arise from dysplastic precursor cells which did not undergo apoptosis and were arrested in ectopic sites during neuronal precursor cell migration (32). If this histogenesis is correct, it is reasonable to speculate that a dysregulation of apoptotic mechanisms rather than lack of response to differentiation inducers may underly the biology of medulloblastoma. Our finding of very low apoptotic index in these medulloblastomas is consistent with such an hypothesis. From the close link between the pathways that regulate apoptosis and those that regulate cell cycle progression and subsequent differentiation, it is conceivable that dysregulation of signaling in these primitive neuroectodermal tumors may occur at a level where its effect on apoptosis and the regulation of cell cycle progression may not be mutually exclusive. We have not been able to demonstrate the expression of the anti-apoptosis protein, Bcl₂ in these medulloblastomas, thus excluding the role of this protein for the observed low apoptotic index.

The accumulation of p27kip1 in postmitotic neurons during neurogenesis (17), the spontaneous development of pituitary tumors in the p27(-/-) mice, as well as the increased forebrain neuronal density and disorganization of the retina observed in these mice (18), suggest a significant role for p27kip1 in the arrest of cell cycle progression in the central nervous system and neural crest derived tissues. As far as we know, this is the first documentation of a relationship between p27kip1 expression and neuroblastic differentiation in primitive neuroectodermal tumors, specifically, medulloblastoma. In the p27kip1 knockout mice, the lack of p27kip1 appears to be marked by a significant relative increase in hematopoietic progenitor cells as compared to the smaller but

significant relative increase to their differentiated descendants. This observation has led to the suggestion that a lack of p27kip1 expression may have a selective effect on the self renewing, mitogen-driven cell cycles that are associated with stem cells (18). The possibility that this may occur during neurogenesis is supported by the increased neuronal density seen in the knockout mice brain. As also demonstrated in the p27kip1 deficient mice, p27kip1 expression is not necessary for cell differentiation in most tissues, but a lack of expression may raise the threshold at which some cells like the ovarian follicular cells respond to differentiation inducing factors. In addition, p27kip1 deficiency may also predispose to uncontrolled proliferation as in the development of spontaneous pituitary tumors in these mice. In this study of medulloblastoma, we have noted that the undifferentiated and highly proliferative population of tumor cells do not express p27kip1. The role of p27kip1 in the proliferation of medulloblastoma and in the determination of the pattern of response of medulloblastoma tumors to differentiation inducing cytokines requires further investigation.

References

- 1 Ewen ME, Sluss HK, Whitehouse LL, Livingston DM: TGF β inhibition of cdk4 kinase is linked to cell cycle arrest .Cell 74: 1009 - 1020, 1993
- 2 Koff A, Ohtsuki M, Polyak K, Roberts JM, Massague J: Negative regulation of G₁ in mammalian cells: inhibition of cyclin E-dependent kinase by TGF- β . Science 260: 536 -539, 1993
- 3 Xiong Y, Hannon GJ, Zhand H, Caso D, Kobayashi R, Beach D: p21 is a universal inhibitor of cyclin kinases. Nature 366: 701 - 704, 1993
- 4 Xiong Y, Xhang H, Beach D: D type cyclins associate with multiple protein kinases and the DNA replication and repair factor PCNA. Cell 71: 505 -5143, 1992
- 5 Harper JW, Adami GR, Wei N, Keymars K, Elledge SJ: The cdk interacting protein cip1 is a potent inhibitor of G1 cyclin dependent kinases. Cell 75: 805 - 816, 1993
- 6 Polyak K, Kato J-Y, Soloman MJ, Sherr CJ, Massague J, Roberts JM, Koff A: p27^{kip1}, a cyclin-cdk inhibitor links transforming growth factor - β and contact inhibition to cell cycle arrest. Genes & Dev 8: 9 - 22, 1994
- 7 Polyak K, Lee M-H, Erdjument-Bromage H, Koff A, Roberts JM, Tempst P, Massague J: Cloning of p27^{kip1} , a cyclin-dependent kinase inhibitor and a potential mediator of extracellular antimitogenic signals. Cell: 59 - 66, 1994

- 8 Ewen ME: p53 dependent response of cdk4 synthesis in transforming growth factor -beta - induced G1 cell cycle arrest. *J Lab Clin Med* 128: 355 - 360, 1996
- 9 El-Deiry WS, Tokino T, Velculescu VE, Levy DB, Parsons R, Trent JM, Lin D, Mercer WE, Kinzler KW, Vogelstein B: Waf1, a potential mediator of p53 tumor suppressor. *Cell* 75: 817 - 825, 1993
- 10 Dulic V, Kaufman WK, Wilson SJ, Tlsty TD, Lees E, Elledge SJ, Reed SI: p53 dependent inhibition of cyclin dependent kinase activity in human fibroblast during radiation induced G1 arrest. *Cell* 76: 1013 - 1023, 1994
- 11 Ravitz MJ, Yan S, Dolce C, Kinniburgh AJ, Wenner CE: Differential regulation of p27 and cyclin D1 by TGF β and RGF in C3H 10T1/2 mouse fibroblasts. *J Cellular Physiol* 168: 510 - 520, 1996
- 12 Liu M, Lee M-H, Cohen M, Bommakanti M, Freedman LP: Transcriptional activation of the cdk inhibitor p21 by vitamin D3 leads to the induced differentiation of the myelomonocytic cell line U937. *Genes & Dev* 10: 142 - 153, 1996
- 13 Parker SB, Eichele G, Zhang P, Rawls A, Sands AT, Bradley A, Olson EW, Harper JW, Elledge SJ: p53 independent expression of p21/cip1 in muscle and other terminally differentiating cells. *Science* 267: 1024 - 1027, 1995
- 14 Gartel AL, Serfas MS, Gartel M, Goufman E, Wu GS, El-Deiry WS, Tyner AL: p21(waf1/cip1) expression is induced in newly nondividing cells in diverse

- epithelia and during differentiation of the Caco-2 intestinal cell line. *Exp Cell Res* 227: 171 - 181, 1996
- 15 Doglioni C, Plosio P, Laurino L, Macri E, Meggiolaro E, Favretti F, Barbarareschi M: p21^{waf1/cip1} expression in normal mucosa and in adenoma and adenocarcinoma of the colon: its relationship with differentiation. *J Pathol* 179: 248 - 253, 1993
- 16 Fredersdorff S, Milne AW, Hall PA, Lu X: Characterization of a panel of novel anti-p21^{waf1/cip1} antibodies and immunohistochemical analysis of p21^{waf1/cip1} expression in normal human tissues. *Am J Pathol* 148: 825 -835, 1996
- 17 Lee MH, Nikolic M, Baptista CA, Lai E, Isai LH, Massague J: The brain specific activator p35 allows cdk5 to escape inhibition by p27kip1 in neurons. *Proc Natl Acad Sci (U S A)* 93: 3259 - 3263, 1996
- 18 Fer ML, Rivkin M, Tasch M, Porter P, Crow CE, Firpo E, Polyak K, Tsai LH, Broudy V, Perlmutter RM, Kaushansky K, Roberts JM: A syndrome of multiorgan hyperplasia with features of gigantism, tumorigenesis and female sterility in p27(kip1)-deficient mice. *Cell* 85: 733 - 744, 1996
- 19 Ponce-Castaneda MV, Lee MH, Latres E, Polyak K, Lacombe L, Montgomery K, Mathew S, Krauter K, Sheinfeld J, Massague J et al: p27kip1: Chromosomal mapping to 12p12-12p13.1 and absence of mutations in human tumors. *Cancer Res* 55: 1211 -1214, 1995
- 20 Spirin KS, Simps JF, Takeuchi S, Kawamata N, Miller CW, Koeffler HP: p27/kip1 mutation found in breast cancer. *Cancer Res* 56: 2400 - 24004, 1996

- 21 Orlow I, Iavarone A, Crider-Milner SJ, Bonilla F, Latres E, Lee MH, Gerald WL, Massague J, Weissman BE, Cordon-Cardo C: Cyclin-dependent kinase inhibitor p57KIP2 in soft tissue sarcomas and Wilms' tumors. *Cancer Res* 56: 1219 - 1221, 1996
- 22 Mousses S, Ozelik H, Lee PD, Malkin D, Bull SB, Andrulis IL: Two variants of the CIP1/WAF1 gene occur together and are associated with human cancer. *Hum Mol Genet* 4: 1089 -1092, 1995
- 23 Hsiao W-LW, Housey GM, Johnson MD, Weinstein IB: Cells that overproduce protein kinase C are more susceptible to transformation by an activated *H-ras* oncogene. *Mol Cell Biol* 9: 2641 - 2647, 1989
- 24 Fuse T, Yamada K, Kato T, Nakanishi M: Heat shock-mediated cell cycle arrest is accompanied by induction of p21 cki. *Biochem Biophys Res Commun* 225: 759 - 763, 1996
- 25 Adesina AM, Nalbantoglu J, Cavenee WK: p53 gene mutation and mdm2 gene amplification are uncommon in medulloblastoma. *Cancer Res* 54: 5649 - 5651, 1994
- 26 Saylor III RL, Sidransky D, Friedman HS, Bigner SH, Bigner DD, Vogelstein B, Brodeur GM: Infrequent p53 gene mutations in medulloblastomas. *Cancer Res* 51, 4721-4723, 1991
- 27 Adesina AM, Dooley N, Yong VW, Nalbantoglu J: Differential role for protein kinase C-mediated signaling in the proliferation of medulloblastoma cell lines . (Submitted)

- 28 Wijsman JH, Jonker RR, Keijzer, van de Velde CJ, Cornellisse CJ, van Dierendonck JH: A new method to detect apoptosis in paraffin section: in situ end-labelling of fragmented DNA. *J Histochem Cytochem* 41: 7 -12, 1993
- 29 Iggo R, Gatter K, Bartek J, Lnane D, Harris AL: Increased expression of mutant forms of p53 oncogene in primary lung cancer. *Lancet* 335: 675 - 679, 1990
- 30 Ladanyi M, Cha C, Lewis R, Jhanwar SC, Huvos AG, Healey JH: Mdm 2 gene amplification in metastatic osteosarcoma. *Cancer Res* 53: 16 - 18, 1993
- 31 Sidman RL, Rakic P: Development of the human central nervous system. In *Histology and histopathology of the nervous system* (edit Haymaker W, Adams RD) Springfield, IL: Charles C Thomas pp 94 - 110, 1992
- 32 Yachnis AT, Rorke LB, Lee V M-Y, Trojanowski JQ: Expression of neuronal and glial polypeptides during histogenesis of the human cerebellar cortex including observation on the dentate nucleus. *J Comp Neurol* 334: 356-369, 1993

CHAPTER 5
CONCLUSIONS

CONTRIBUTIONS TO ORIGINAL KNOWLEDGE

1. We have shown that p53 gene, a major regulator of cell cycle progression, particularly in response to DNA damage, is mutated in only 11% of medulloblastomas.
2. In addition, p53-mdm2 interaction is not a major target in the neoplastic transformation of medulloblastoma.
3. Furthermore, we demonstrate for the first time that medulloblastoma cell lines DAOY, D283-Med and D341-Med differentially express PKC isoforms α and ζ . These cell lines do not express PKC β 1, β 11, γ , δ and ϵ .
4. PMA responsive PKC α plays a role in the proliferation of DAOY but not in D283-Med and D341-Med.
5. We also demonstrate for the first time that there is a relationship between the expression of cdk inhibitor p27kip1 and growth inhibition / neuroblastic differentiation in medulloblastoma.

These findings are indicative of significant molecular heterogeneity among medulloblastoma cell lines and reflect molecular heterogeneity among medulloblastoma tumors.

Conclusions

In this study, we have shown that p53 mutations are infrequent in medulloblastoma. We also show that p53-mdm2 interaction may not be an alternative pathway for p53 inactivation in medulloblastoma. In addition, p53 nuclear immunoreactivity reveals a subset of tumors in which p53 protein is detectable in rare to a few cells. Relative to the entire cell population, these p53 positive cells often account for less than 1% of the cell population. In gliomas, clonal expansion of cells which acquire a p53 mutation has been suggested as a major mechanism for tumor progression from low grade glioma to high grade glioblastoma multiforme (1). These secondary glioblastomas appear to represent a pathogenetically distinct subset of glioblastoma multiforme (2). It is currently unknown if the recurrent tumor in children with medulloblastoma whose primary tumor shows few to rare p53 positive cells, maintain the same pattern of immunoreactivity or show a clonal expansion of the p53 positive population. Since children with recurrent tumors do not frequently undergo a rebiopsy or resection, a retrospective analysis may be difficult. Future systematic rebiopsy of recurrent tumors and their analysis for p53 protein expression may help in answering this question and provide a clue to the possible biological significance of these few p53 positive cells.

We have also implicated cPKC α in the proliferation of the medulloblastoma cell line DAOY, but not in D283-Med and D341-Med. This finding suggests that PKC-mediated signaling may be important in the proliferation of a subset of medulloblastomas. The clinical significance of this finding, therefore, is that growth modulation based therapeutic approaches addressed at modulating second messenger

pathways, such as the use of the PKC inhibitor, Tamoxifen, which is currently used in clinical trials in gliomas, may have application in a subset of medulloblastomas. To be able to tailor such therapy to the individual patient who is most likely to benefit from it, will require the immunohistochemical analysis of these tumors for the overexpression of PKC α protein. However, a major limiting factor is that currently available antibodies to PKC α do not react in paraffin embedded tissue. This situation also limits our ability to initially assess currently available archival medulloblastoma tumors, which are largely paraffin embedded. Such an analysis would have provided valuable data on the clinical utility of PKC α analysis in medulloblastoma tumors.

We also demonstrate that the expression of cdk inhibitor, p27kip1, is associated with growth retardation and neuroblastic differentiation in medulloblastoma. Since postsurgical fatal outcome in medulloblastoma is related to the growth of the residual tumor mass left behind, especially when complete resections are impractical, it is reasonable to speculate that the expression of cdk inhibitors, p27kip1 and p21cip1, in medulloblastoma, either by pharmacological methods or gene therapy, using for example, adenovirus expression vectors (4) containing cDNA for p27kip1 or p21cip1, may offer the opportunity to reduce the growth of postsurgical residual medulloblastoma tumor cells. Whether such transfected tumor cells will undergo differentiation in the presence of growth inducing factors, such as NGF, awaits future studies.

A major and critical component of the clinical management of medulloblastoma, is the ability to be able to predict the prognosis for each individual patient. While clinical

parameters, such as surgical resectability, age at presentation, and the presence or absence of metastases at presentation have significant prognostic relevance (5), the histologic features of these tumors have not consistently shown prognostic significance, except for the desmoplastic medulloblastoma which has a better prognosis when compared with the classic medulloblastoma (6). As shown in this study, there is a significant molecular heterogeneity between medulloblastoma cell lines and tumors, a finding which suggests the need for the identification of specific molecular subsets among medulloblastomas. It is noteworthy that the expression of p27kip1 is associated with significant growth inhibition and is more frequently seen in the pale islands of desmoplastic medulloblastoma. This raises the suggestion that the expression of p27kip1 may account in part for the better prognosis of this subset of medulloblastomas. Immunohistochemical analysis of medulloblastomas for the expression of p27kip1 may, therefore, identify a molecular subset of medulloblastomas with possibly better prognosis.

Similarly a recent study indicates differential expression of the neurotrophin receptor, *trk C*, in medulloblastoma with a correlation between *trk C* expression and better prognosis (7). Since the expression of neurotrophin receptors occurs as a maturation step during neurogenesis, the expression of *trk C* can be regarded as a marker of better differentiation and suggests the possibility that these tumors may be able to respond to differentiation inducing neurotrophic factors. One would anticipate that *trk C* expression in such tumors would correlate with foci of neuroblastic differentiation, and

lower proliferation index. Therefore, *trk C* expression provides another molecular marker of prognostic significance in medulloblastoma.

Furthermore, 17p deletion in medulloblastomas has been suggested to be an independent poor prognostic indicator (8). This locus probably includes more than one single gene. Such gene/s that may play a role in the biology of this subset of medulloblastomas remain to be identified. Hence, this locus may provide other gene products with potential application in gene therapy for this specific subset of medulloblastomas.

Therefore, molecular subtyping of medulloblastomas may not only provide prognostic markers, but allow for the use of newer therapeutic techniques, such as gene therapy, for selective targeting of critical genetic events in subsets of medulloblastoma. This would be a radical departure from the current management approach of "one coat fits all". Accumulating evidence continues to indicate that although all "blue" cells may share similar malignant morphologic phenotype, they do not necessarily share similar molecular phenotype with implications for differing tumor biology.

References

- 1 Sidransky D, Mikkelsen T, Schehheimer K, Rosenblum M, Cavenee W, Vogelstein B: Clonal expansion of p53 mutant cells is associated with brain tumor progression. *Nature* 355: 846-847, 1992
- 2 Watanabe K, Tachibana O, Sata K, Yonekawa Y, Kleihues P, Ohgaki H: Overexpression of the EGF receptor and p53 mutations are mutually exclusive in the evolution of primary and secondary glioblastomas. *Brain Pathol* 6: 217 - 223, 1996
- 3 Baltuch GH, Dooley NP, Villemure J-G, Yong VW: Protein kinase C and growth regulation of malignant gliomas. *Can J Neurol Sc* 22: 264 - 271, 1995
- 4 Fueyo J, Gomez-Manzano C, Alfred Young WK, Clayman GL, Liu T-J, Bruner J, Levin VA, Kyritsis AP: Adenovirus-mediated *p16/CDKN2* gene transfer induces growth arrest and modifies the transformed phenotype of glioma cells . *Oncogene* 12: 103 -110, 1996
- 5 Albright AL, Wisoff JH, Zelter PM, Boyett JM, Rocke LB: Effects of medulloblastoma resection on outcome in children: a report from the children's cancer group. *Neurosurgery* 38: 265 - 271, 1996
- 6 Russell DS, Rubinstein LJ: Pathology of tumors of the central nervous system 5th edition, Williams & Wilkins, 251 - 270, 1989
- 7 Segal RA, Goumenova LC, Kwon YK, Stiles CD, Pomeroy SL: Expression of neurotrophin receptor *trk C* is linked to a favorable outcome in medulloblastoma. *Proc Natl Acad Sci (USA)* 91: 12867 - 12871, 1994

- 8 Batra SK, McLendon RE, Koo JS, Castelino-Prabhu S, Fuehs HE, Krischer JP, Friedman HS, Bigner DD, Bigner SH: Prognostic implications of chromosome 17p deletions in human medulloblastomas. *J Neurooncol* 24: 39 - 45, 1995