

**Impact of Ventilation System Operation and Building Products  
On Perceived Indoor Air Quality**

**Wafa Sakr**

**A Thesis**

**In**

**The Department of**

**Building, Civil and Environmental Engineering**

**Presented in Partial Fulfillment of the Requirements  
for the Degree of Masters of Applied Science at  
Concordia University  
Montreal, Quebec, Canada**

**August 1999**

**© Wafa Sakr, 1999**



**National Library  
of Canada**

**Acquisitions and  
Bibliographic Services**

395 Wellington Street  
Ottawa ON K1A 0N4  
Canada

**Bibliothèque nationale  
du Canada**

**Acquisitions et  
services bibliographiques**

395, rue Wellington  
Ottawa ON K1A 0N4  
Canada

*Your file Votre référence*

*Our file Notre référence*

**The author has granted a non-exclusive licence allowing the National Library of Canada to reproduce, loan, distribute or sell copies of this thesis in microform, paper or electronic formats.**

**The author retains ownership of the copyright in this thesis. Neither the thesis nor substantial extracts from it may be printed or otherwise reproduced without the author's permission.**

**L'auteur a accordé une licence non exclusive permettant à la Bibliothèque nationale du Canada de reproduire, prêter, distribuer ou vendre des copies de cette thèse sous la forme de microfiche/film, de reproduction sur papier ou sur format électronique.**

**L'auteur conserve la propriété du droit d'auteur qui protège cette thèse. Ni la thèse ni des extraits substantiels de celle-ci ne doivent être imprimés ou autrement reproduits sans son autorisation.**

**0-612-43651-9**

**Canada**

## **ABSTRACT**

### **Impact of ventilation system operation and building products on perceived indoor air quality**

**Wafa Sakr**

Systematic studies conducted over the last few years suggest that many of the building materials and consumer products are the main source of indoor pollution and consequently they affect the perceived indoor air quality. Because of the diversity of the sources and types of contaminants, many have suggested that the best technique to ensure acceptable indoor air quality is to ventilate the building. However, no systematic study has shown to what extent this solution can be useful and when this solution is not practical.

Currently, the ventilation rate in non-industrial buildings is determined per human occupant regardless of the pollutant emissions from building materials, ventilation systems and other sources. With the intention of saving energy, the ventilation systems in many office buildings are turned off during the night. This process may reduce the quality of indoor air during day time, because of accumulation of contaminants in the air as well as the process of sorption when the air pollutants absorbed by cleaner surfaces at night are reemitted during the day.

This thesis reports the results of a series of experimental studies on the impact of operation of ventilation system and the mixture of building materials on the perceived air quality. Experiments were performed in test chambers as well as in office buildings. Untrained panels of approximately 35 subjects assessed the air quality in terms of acceptability and odor intensity. Experiments were performed using test chambers to

determine the exposure-response relationship for tested building materials.

The results of ventilation strategy experiments indicated that intermittent ventilation reduces the daytime air quality, and in order to maintain the same level of acceptability of the air as for continuous ventilation the ventilation rates during the day must be increased. The exposure-response relationship was then used to quantify the required increase in ventilation rate in order to maintain certain level of acceptability of the indoor air.

The additive effect experiment revealed an equivocal improvement in perceived air quality when two materials were combined. However, to achieve the same level of acceptability, more ventilation is needed for a mixture of two materials due to a more flat nature of exposure-response relationship of combined material than for a single material.

## **Acknowledgments**

My deepest gratitude and warm thanks to my supervisors, professor Fariborz Haghighat and professor Michael Von Grünau for their magnificent contribution and great help to make this work a success.

My sincere appreciation to Dr. Lars Gunnarsen, at the Danish Building Research Institute for his valuable advises and friendly discussion by e-mail.

My special thanks to Mr. Joe Hrib for his craftsmanship which helped build the test facilities; to Mr. Jacque Payer and Joseph Zilkha for their often sought services; to my friends, Julia Reduca Popa and Chang Seo Lee for their assistance in the laboratory during the course of this work, and to all panels who participate in this projects.

My hearty thanks to my parents, my two brothers and sister for their love, encouragement and continuous support during my studies.

## TABLE OF CONTENTS

	<b>PAGE</b>
List of Figures .....	viii
List of Tables .....	x
 <b>CHAPTER</b>	
1.0 INTRODUCTION.....	1
1.1 OVERVIEW OF THE INDOOR AIR QUALITY PROBLEMS .....	1
1.2 THE PERCEPTION OF INDOOR AIR .....	3
1.2.1 Sensory mechanisms .....	3
1.2.2 Odors in indoor environment .....	4
1.2.3 Sensory evaluation of indoor air quality .....	4
1.3 MAIN OBJECTIVES OF THIS WORK.....	5
 2.0 LITERATURE REVIEW .....	 7
2.1 PERCEIVED INDOOR AIR QUALITY AND ODOR .....	7
2.2 THE NEW UNITS OF PERCEIVED AIR QUALITY.....	10
2.3 ODOR INTENSITY AND OLFACTORY SENSATION.....	12
2.4 TRAINED AND UNTRAINED PANELS.....	14
2.5 ADAPTATION.....	18
2.6 THE EFFECT OF INDOOR-CLIMATE-RELATED PARAMETERS ON THE EMISSION FROM BUILDING MATERIAL.....	20
2.7 SENSORY VS NON SENSORY TECHNIQUES TO EVALUATE INDOOR AIR QUALITY.....	23
2.8 CONCLUSION.....	23
 3.0 EXPERIMENTAL SET-UP AND METHODOLOGY.....	 31
3.1 CHAMBER DESCRIPTION .....	31
3.2 BUILDING PRODUCTS .....	34
3.3 SENSORY PANEL .....	36
3.4 PROCEDURE.....	37
3.5 DATA HANDLING AND STATISTICS .....	38
 4.0 RESULTS .....	 41
4.1 VENTILATION STRATEGIES.....	41
4.1.1 Continuous ventilation experiment .....	41
4.1.2. Intermittent ventilation experiment .....	43
4.1.3. Dilution experiment .....	47
4.2 FIELD MEASUREMENTS: .....	54
4.3 THE ADDITION EFFECT OF BUILDING PRODUCTS ON THE PERCEIVED AIR QUALITY .....	56

5.0 DISCUSSION .....	74
5.1 EFFECT OF VENTILATION STRATEGIES ON PERCEIVED AIR QUALITY .....	74
5.2 THE ADDITIVE EFFECT OF BUILDING PRODUCTS ON PERCEIVED AIR QUALITY .....	76
6.0 CONCLUSIONS AND RECOMMENDATIONS .....	79
6.1 EFFECT OF VENTILATION STRATEGIES ON PERCEIVED AIR QUALITY .....	79
6.2 THE ADDITIVE EFFECT OF BUILDING PRODUCTS ON PERCEIVED AIR QUALITY .....	79
6.3 ACCEPTABILITY VS. ODOR INTENSITY .....	80
6.3 FUTURE WORK .....	80
REFERENCES.....	82
APPENDICES.....	87
APPENDIX I: CALIBRATION RESULTS OF THE TEST CHAMBERS.....	87
APPENDIX II: THE AIR QUALITY ASSESSMENT RESULTS FOR EACH PARTICIPATING INDIVIDUAL.....	99
APPENDIX III: ANOVA RESULTS.....	143
APPENDIX IV: PHOTOGRAPHS.....	151

## LIST OF FIGURES

	<b>PAGE</b>
FIGURE 2.1 : VOTING SCALE AND QUESTIONS USUALLY USED WITH THE REPRESENTATIVE PANEL.....	16
FIGURE 3.1 : THE CLIMPAQ.....	31
FIGURE 3.2 : THE EXPERIMENTAL SET-UP.....	32
FIGURE 3.3 : DILUTION SYSTEM.....	33
FIGURE 3.4 : SETS OF ORIFICES PLATES USED FOR THE DILUTION.....	33
FIGURE 3.5 : PVC & CARPET SAMPLES INSIDE THE TEST CHAMBERS.....	36
FIGURE 3.6 : ACCEPTABILITY AND ODOR INTENSITY VOTING SHEET.....	39
FIGURE 4.1 : MEAN ACCEPTABILITY VOTES FOR CONTINUOUS VENTILATION.....	42
FIGURE 4.2 : MEAN ODOR INTENSITY VOTES FOR CONTINUOUS VENTILATION...	42
FIGURE 4.3 : MEAN ACCEPTABILITY VOTES FOR INTERMITTENT VENTILATION...45	45
FIGURE 4.4 : MEAN ODOR INTENSITY VOTES FOR INTERMITTENT VENTILATION.....	45
FIGURE 4.5 : MEAN ACCEPTABILITY VOTES WITH CONTINUOUS AND INTERMITTENT VENTILATION.....	46
FIGURE 4.6 : MEAN ODOR INTENSITY VOTES WITH CONTINUOUS AND INTERMITTENT VENTILATION.....	46
FIGURE 4.7 : ACCEPTABILITY AS A FUNCTION OF DILUTION FACTOR.....	49
FIGURE 4.8 : ODOR INTENSITY AS A FUNCTION OF DILUTION FACTOR.....	51
FIGURE 4.9 : EXPOSURE-RESPONSE RELATIONSHIP.....	53
FIGURE 4.10 : MEAN ACCEPTABILITY VOTES AT CONTINUOUS AND INTERMITTENT VENTILATION.....	55
FIGURE 4.11 : MEAN ODOR INTENSITY VOTES AT CONTINUOUS AND INTERMITTENT VENTILATION.....	55
FIGURE 4.12 : MEAN ACCEPTABILITY AND 95% CONFIDENCE INTERVAL WHEN CHAMBER EXHAUSTS WERE DILUTED.....	58



FIGURE 4.13 : ACCEPTABILITY AS A FUNCTION OF DILUTION FACTOR.....	60
FIGURE 4.14 : ODOR INTENSITY AS A FUNCTION OF DILUTION FACTOR.....	62
FIGURE 4.15 : EXPOSURE RESPONSE RELATIONSHIP.....	63
FIGURE 4.16 : MEAN ACCEPTABILITY AND 95% CONFIDENCE INTERVAL WHEN CHAMBER EXHAUSTS WERE DILUTED ( CASE OF COMBINED MATERIALS).....	65
FIGURE 4.17 : ACCEPTABILITY AS A FUNCTION OF DILUTION FACTOR (CASE OF COMBINED MATERIALS).....	68
FIGURE 4.18 : ODOR INTENSITY AS AFUNCTION OF DILUTION FACTOR (CASE OF COMBINED MATERIALS).....	69
FIGURE 4.19 : EXPOSURE RESPONSE RELATIONSHIP (CASE OF COMBINED MATERIALS).....	70
FIGURE 4.20 : RELATIONSHIP BETWEEN ACCEPTABILITY AND ODOR INTENSITY.....	72
FIGURE 4.21 : EXPERIMENTAL STANDARD DEVIATION OF THE ACCEPTABILITY VOTE.....	73

**LIST OF TABLES**

	<b>PAGE</b>
TABLE 2.1: SUMMURY OF SOME CHEMICAL AND SENSORY TESTS CONDUCTED TO DATE.....	25
TABLE 3.1: TESTED CONSTRUCTION PRODUCTS.....	34
TABLE 3.2: TEST CONDITIONS IN THE TEST CHAMBERS BASED ON A MODEL ROOM WITH AN AIR EXCHANGE RATE OF 2 H <sup>-1</sup> .....	35
TABLE 3.3: DATA FOR PARTICIPATING SUBJECTS.....	40
TABLE 4.1: RESULTS OF CONTINUOUS VENTILATION EXPERIMENT.....	42
TABLE 4.2: RESULTS OF INTERMITTENT VENTILATION EXPERIMENT.....	45
TABLE 4.3: SUMMURY OF THE DILUTION EXPERIMENT RESULTS.....	48
TABLE 4.4: RESULTS OF THE SENSORY TESTING CARRIED OUT IN REAL OFFICES.....	55
TABLE 4.5: SENSORY ASSESSMENT RESULTS FOR DILUTION EXPERIMENT WHEN EACH CHAMBER CONTAINED SAMPLES OF ONE BUILDING PRODUCTS.....	57
TABLE 4.6: SENSORY ASSESSMENT RESULTS FOR DILUTION EXPERIMENT WHEN THE TEST CHAMBER CONTAINED SAMPLES OF TWO BUILDING PRODUCTS.....	64
TABLE 5.1: ACCEPTABILITY ASSESSMENTS AT INTERMITTENT AND CONTINUOUS VENTILATION WITH THE REQUIRED DILUTION.....	75
TABLE 5.2: ACCEPTABILITY ASSESSMENTS FOR INDIVIDUAL AND COMBINED MATERIALS WITH THE REQUIRED DILUTION NEEDED TO REACH THE ACCEPTABILITY OF AN EMPTY CHAMBER.....	77

# CHAPTER I

## INTRODUCTION

### 1.1 Overview of indoor air quality problems

Exposure to pollutants commonly found in non-industrial indoor air have, in the past decade, become a main cause for international health concern. Of major significance, is a class of pollutants called volatile organic compounds (VOCs). Some known sources of these contaminants are building materials, furnishings, cleaning and personal care products. Human exposure to VOCs, believed to be perceived by the olfactory system, can elicit a variety of symptoms (Hudnell et al., 1990). These chemical compounds may often be present in concentrations several orders of magnitude lower than measurable limits, and the only sign of their presence may occur via the sense of smell (Iwashita et al., 1990).

The notion that odor level perceived by visitors to an occupied space could offer a quantitative criterion for ventilation requirements in buildings goes back to 1930. Yaglou et al (1936) applied psychophysical scaling to study the level of occupancy odor depended on ventilation rate in nonsmoking environment. Both American and European standards have relied explicitly on Yaglou's results. The recommended ventilation flow rate did not however prevent serious complaints concerning air quality in many buildings. It was also found that the human bioeffluents comprise very little of the pollution sources, whereas materials in spaces and ventilation systems, ignored for a century as pollution sources in standards, were the major cause of the poor air quality observed in many buildings. This finding allowed the introduction of a new philosophy of ventilation that

acknowledged all pollution sources (construction materials, furniture ....) in addition to smoking and bioeffluents caused by humans (Fanger,1989).

In some buildings, the reason for poor air quality may be obvious: actual air supply may be less than the designed or required supply. Even where compliance with ventilation standards are observed, and measured concentrations of contaminants are several orders of magnitudes below existing limits, it was reported that 60% of the occupants still found the air unacceptable (Fanger, 1989).

In both sensory and chemical terms, the emissions from building materials depend on the following parameters: temperature, humidity (Fang et al., 1996) (Wolkoff, 1998) time after manufacture, air velocity, ventilation rate (Gunnarsen, 1993) surface treatments and pollution from other activities adsorbed on the materials (Wolkoff et al., 1991). Human perception of the ambient air quality depends on the chemical and physical properties of the air. Berglund and Cain (1989) have shown that the physical properties of the air will exert a strong influence on how air quality is judged. They have shown that the air temperature will strongly affect the perception of acceptable air quality with humidity having less effect.

At the design stage it is possible to predict the perceived air quality of a space based on an estimation of the total sensory pollution load in the space which could be found by adding the loads from the present individual materials. One way of providing data on individual materials is full-scale experiments in environmental chambers. This approach is expensive and time consuming. A simple and inexpensive test method for measuring chemical emission is the use of small-scale test chambers, and a similar procedure may be used for quantifying the sensory emission from materials (Knudsen et al., 1993).

## **1.2 The perception of indoor air**

Neither chemical nor physical measurements were able to identify reasons for increased complaints about indoor air quality. Interestingly, it was observed that human senses were superior to chemical analysis for assessing the quality of perceived indoor air in most occasions.

### **1.2.1 Sensory mechanisms**

The sensory systems, which link us with the outside world, are functionally identical. They transmit signals in the form of coded messages from the receptor to the central nervous system for evaluation and eventually relayed back to the receptor. For the various sensory systems, the interface between external and internal environments may be either mucous or the skin. Responses to chemical stimuli are the result of interaction between external molecules and sensory receptors, made up of proteins. It will therefore be expected that responses to chemical stimuli will be equally dependent on the nature of the stimulus and receptor properties as well as on personal factors. Somethesia (the common chemical sense) and olfaction have been shown to be the directly associated with indoor air quality. While somethesia is associated with mucosal irritation, olfaction is linked with odor (ECA-IAQ, 1999). The two senses are influenced differently by adaptation (Engen, 1986). The olfactory sense is sensitive to odors and likely to adapt while the common chemical sense is sensitive to irritants and not likely to adapt (Gunnarsen, 1990).

The nose is a sensitive instrument, it perceives the presence of pure chemicals and chemical mixtures at levels much lower than the detection limit of most conventional analytical instruments. The sense of olfaction is viewed as chemical sense because molecules interacting with receptor molecules are the stimulus prerequisites for eliciting

the sensations. Odorous properties of volatile molecules are linked to the formation of reversible, low energy bindings with protein receptors. The specificity of these receptor bindings depends on the actual topography of the receptor site, which is still unknown.

The binding energy is accounted for by van der Waals forces, including hydrogen bonding and hydrophobic bonding. (ECA-IAQ, 1999)

The science of smelling is an interdisciplinary science that encompasses biology, physiology, chemistry, psychology, statistics and environmental sciences. Indoor air sciences employ olfactory sciences as a tool to investigate sources of indoor air pollution.

### **1.2.2 Odors in indoor environment**

Historically, the presence of odor in indoor environment has been associated with dangerous places having unsanitary conditions. Moreover, odor in indoor environment is undesirable because it may indicate: an annoyance factor for the exposed occupants, low air exchange between indoor and fresh outdoor air, or the emission of VOCs (Moschandreas, 1992).

Measurement of odor qualities is affected by several factors such as temperature, relative humidity (Berglund and Cain, 1989; Bluysen et al., 1996), the frequency and length of exposure to the odorant (Gunnarsen, 1990; Gunnarsen and Fanger, 1992) and by the education/ culture of the evaluator.

### **1.2.3 Sensory evaluation of indoor air quality**

Sensory analyses are based on the use of human subjects as measuring instruments. Individuals do differ in sensory sensitivity, response behavior and value judgements. Some of these differences are environmentally induced, some are linked to

person and personality characteristics. Furthermore, a number of biological variables influence olfactory sensitivity. The most important is the decrease in sensitivity with age (Schiffman, 1996). Sensory methods are still preferred to physico-chemical methods as an evaluation tool since the later are often insensitive to low odor level or pollutants which are irritating to the olfactory system. Nonetheless, the olfactory system is not only insensitive to some harmful air pollutants (e.g. carbon monoxide and radon), but could also fail to quantitatively link the sensory effects and toxicity for other pollutants. Therefore the sensory method cannot be regarded as a universal tool for assessing health impact of indoor air.

Sensory evaluation of perceived indoor air quality may be used to study the impact of physical factors on perceived air quality, for investigation of exposure and response relationships, for evaluation of indoor air quality in new or refurbished buildings, for identification and quantification of pollution sources in buildings and for development of a testing system for building materials (ECA-IAQ 1999).

### **1.3 Main Objectives of this work**

The main objective of this thesis is to investigate the impact of ventilation operation on the quality of indoor air as perceived by a panel of subjects. The quality of indoor air is measured in terms of acceptability and odor intensity. The more specific objectives are:

- To assess the influence of nocturnal ventilation reduction on the perceived air quality, in terms of acceptability and odor intensity, in comparison with the case of continuous ventilation.

- To quantify the required increase in ventilation rates in order to maintain the acceptability of the air when intermittent ventilation is used.
- To investigate the additive impact of building materials on the perceived air quality.

It is expected that the results of this work will help to establish ventilation requirements based on odor criteria, to help building designers and architects to select materials based on odor perception, and finally to predict the perceived air quality of a space based on the total sensory pollution load which could be found by knowing the existing materials in that space.



## CHAPTER II

### LITERATURE REVIEW

#### 2.1 Perceived indoor air quality and odor :

Odor has lately been a topic of interest because odor and stuffiness are a notable source of annoyance in the indoor climate. WHO (1987) in Air Quality Guidelines for Europe, discuss odor annoyance levels in terms of what may be acceptable as “the concentration at which not more than a small proportion of the population ( less than 5%) experience annoyance for a small part of the time”. In another report (WHO 1989) they recommend that unwanted odors should not be present such that 50% of people can detect them and that 90% should be free of sensory irritation (EURO Reports 111, WHO 1989).

ASHRAE Standards (1989) state that an acceptable air quality is “air in which there are no known contaminants at harmful concentrations and with which a substantial majority (80% or more) of the people exposed do not express dissatisfactions”. (Standards 62, ASHRAE 1989).

European Guidelines (European Concerted Action 1992) state that indoor air quality has two requirements; first the health risk should be negligible and then, the air should be pleasant rather than stale, stuffy and irritating. (Report 11, 1992)

Parine et al. (1994) analyzed the responses of 300 occupants to different questions regarding air quality in two buildings and they suggest that the perception of indoor air quality is complex where odor is of less importance than perceptions of “ freshness”.

They concluded that the odor production by building materials may be as important as

the occupants odor production in determining the perception of air quality and there is no single measurable definition of acceptable indoor air quality and further research is needed to find the influence of 'physical' parameters on occupant judgement before odor is accepted as a surrogate for poor air quality.

Knudsen et al. (1993) conducted experiments using small-scale chambers with different volume and a full-scale environmental chamber, they quantified the sensory emissions from four materials placed in the different chambers by a trained sensory panel (15 judges). They concluded that the sensory emission rate for individual materials in a real space can be predicted by experiments in small-scale test chambers because the air quality assessed in a diffuser was not different from the same air assessed immediately upon entering the space. However, they recommend keeping the ratio between ventilation rate and area of material similar to the conditions in the real space.

Berglund et al. published a report in (1990) about the sensory criteria for healthy buildings. The aim of the report was to define criteria for healthy building from a sensory effect point of view and to discuss requirements on methods of testing sensory effects.

They said that sensory perceptions are real and possible to explicate, manipulate and measure. Common features of the sensory systems are multisensory perceptions, perceptual interactions and recognition of chemical and sensory patterns of the indoor air. They concluded that unwanted odorous compounds should not be present indoors in concentrations exceeding the 50% for detection among the occupants and sensory irritant should never exceed 10% for detection, and healthy building priority should be given to protect the sensitive occupant population.

Wolkoff (1994) developed a system to label the emission of VOCs from new building

products according to their impact on comfort, the purpose of this research was to explore the possibilities of ranking and evaluating the emission of VOCs from building products based on emission testing of potential VOCs selected on the basis of health assessment, it was decided to focus on odor and mucous irritation. The pilot study evaluated 9 building products: 3 carpet, 3 sealant, and 3 waterborne paints, and the goal was to determine the time during which a new building product may cause air quality problems, based on odor and mucous irritation thresholds. It was found that odor thresholds are magnitudes lower than mucous irritation thresholds and the time value can be used as a label and for ranking purposes.

Knudsen et al. (1997) studied the exposure-response relationship between the concentration of air pollutants and perceived air quality, they tested 8 materials often found indoors. Samples of the materials were placed in a ventilated test chamber and the exhaust air from this chamber was diluted with different rates of unpolluted air to obtain different concentrations. A sensory panel assessed the perceived quality of the polluted air. They found that the exposure-response relationship between the pollutant concentration and perceived air quality differed between the eight investigated materials and that the sensory pollution load for a material change with the pollution concentrations. They proposed a simple measurement method based on a dilution system connected to a ventilated small-scale test chamber to characterize the emissions from materials in sensory and chemical terms.

Balez (1998) studied the olfactory effect in the built environment. Her research was based on user's statements. She introduced the "olfactory effect" as a new tool for architectural design. This new method consists in analyzing anecdotes about olfactory phenomena, and

it requires a very interdisciplinary approach, which relates physico-chemicals elements of odor to its perception.

It is doubtful that a single approach or value can be adopted to universally characterize good air quality, which is both healthy and comfortable. The issue is far more complex and requires an interdisciplinary approach. However, the guidelines developed can provide background information, which may be useful for both general and specific purposes.

## **2.2 The new units of perceived air quality**

Fanger (1988) introduced two new units, the olf and the decipol to quantify air pollution sources and air pollution perceived by humans indoors and outdoors. The olf is introduced to quantify air pollution sources. One olf is the emission rate of air pollutants (bioeffluents) from a standard person and any other pollution source may be quantified by the number of standard persons (olf) required to cause the same dissatisfaction as the actual pollution source. The decipol is introduced to quantify air pollution perceived by humans, one decipol is the pollution caused by one olf ventilated by 10 l/s of unpolluted air.

In 1989, Fanger introduced the new comfort equation for indoor air quality (using decipol and olf units), the equation incorporates all pollution sources in a space to derive a ventilation level that appeals to human perceptions. The comfort equation acknowledged for the first time all pollution sources, not just human bioeffluents and smoking, and it quantified the quality of indoor and outdoor air as perceived by human being.

It established a rational basis for future ventilation standards.

Osland et al. (1994) discussed the new units of perceived air quality and the validity of using these units to determine ventilation rates. They concluded that still queries about the derivation of the olf / decipol approach and further research needed to examine the methodology used to determine the olf and decipol, as well as investigating the value of the new units in assessing air quality.

Pejtersen et al. (1990) introduced a new simplified method to quantify the total pollution load in buildings caused by materials, occupants and tobacco smoking. The objective was to determine the total olf load from measurements of perceived indoor air quality in decipol and outdoor air supply. The contribution from human bioeffluents and tobacco smoking were calculated from CO<sub>2</sub> and CO measurements. The olf load of the building itself was found as the total load (calculated from the comfort equation\*) minus bioeffluent and smoking. Nine office buildings were studied using this method and a trained panel assessed the perceived air quality. From the results of this study they found that 62% of the pollution sources came from materials in the spaces and in the ventilation system while the occupants contribution did not exceed 24%. They concluded that the building itself is a serious pollution source and the first step to reduce unnecessary pollution sources is to identify the pollution load.

In a research conducted by Bluyssen et al. (1993) the two available methods to evaluate air quality (the decipol method and the threshold method) were compared. It was concluded that for perceived air qualities above 15 decipol the two methods showed a correlation, and at perceived air qualities below 15 decipol no relation between the two

---

\* The comfort equation:  $Q = 10G / (C_i - C_o)$  where Q is the ventilation rate (l/s), G is the total pollution sources (olf), C<sub>i</sub> is the perceived indoor air quality (decipol) and C<sub>o</sub> is the perceived outdoor air quality(decipol) (Fanger 1989)

methods was found. When evaluating indoor air quality in buildings, the perceived air quality will be below 15 decipol, therefore the decipol method is the method to be used.

The old and decipol method do provide a rational basis for identifying the source of pollution, calculate ventilation requirements, and to predict and measure indoor air quality. However, it suffers from both theoretical (assumed linearity between perceived air quality and pollution source) and practical limitations (trained panel costly to maintain).

### 2.3 Odor intensity and olfactory sensation

A series of five experiments were performed by Cain (1969) dealing mainly with normal aliphatic alcohols. It was found that there are reliable differences among the exponents of the psychophysical power functions for odorants\*. There was a perfect rank-order correlation between the size of the exponent and the water-solubility of the odorants. Although the exponents were higher when the stimuli were delivered with an air-dilution olfactometer than when was sniffed from cotton swabs. They concluded that the rate of growth of suprathreshold odor intensity is partially dependent on the solubility characteristics of odorants.

Berglund et al. (1971) obtained individual scales of odor intensity for 28 different chemical compounds using the method of magnitude estimation. A panel of 11 members participated in an experiment with 196 olfactory stimuli which differed in both quality

---

\* A mathematical relationship between the magnitude of the physical stimulus dimension and the magnitude of sensation called the power law (Stevens, 1957). According to the power law, sensory magnitude is proportioned to physical intensity of the stimulus raised to a power:  $S = kI^b$   
 S: sensation, k: constant (takes into account the choice of units used in a given sensory dimension), I: stimulus intensity or concentration, b: is the exponent which reflects the relation between sensory magnitude and stimulus magnitude and it differs between odorants. The relationship between sensation (or psychological magnitude) and stimulus magnitude can be plotted as a curve called a power function. (Schiffman, Sensation and Perception, 1996)

and intensity. It was found that power functions described the relationship between partial vapor pressure of the odorants and their subjective odor intensity for all the panel members and all exponents were less than one and varied greatly between the participated members. As a result, the variation in the exponents is characteristic of the odorants rather than of response bias.

Engen (1982) studied the relationship between odor stimuli and odor sensation and he found that for individual chemical compounds the relation between perceived intensity and concentration vary between odorants.

The study done by G. Iwashita et al (1990) was to investigate indoor air quality by making subjective assessment of perceived air pollution caused by human bioeffluents.

They used 107 subjects as judges to report the odor intensities and acceptability of bioeffluents from 54 other subjects as occupants. The experiments were conducted in a full-scale test chamber. The percentage of dissatisfied judges expressed as a function of Yaglou's odor intensity. They concluded that the mean odor intensity has strong correlation with the percentage of dissatisfied, and a ventilation rate approximately 7 l/s/person was required to satisfy 80% of judges entering the chamber.

Hudnell et al. 1990 published a report, which described evidence indicating that perceived odor intensity diminishes during prolonged exposure while perceived intensity of irritation showed no evidence of decay. They concluded that both odor and irritation contributed to the perception of air quality.

Karpe et al. (1995) presented a method aimed to measure the odor intensity in indoor air. This method is based on the comparison of the unknown odor intensity with the reference of 8 butanol solutions. A sensory panel of 21 persons has been trained in order to

measure the odor intensity of different polluted sources (building materials) using the olfactory matching method, based on the comparison of an unknown odor intensity with the reference of 8 butanol solutions. The panel was asked to estimate the odor in terms of intensity and not in terms of quality. Three wallpapers and two floor covering were conditioned in a 1 m<sup>3</sup> stainless steel test chamber. They concluded that the olfactory matching method is reliable and the floor coverings tested are less odorous than the wall coverings but no correlation exists between TVOC emission rates and the odor intensities for the studied materials.

The majority of the indoor volatile air contaminants are odorous. For odorous as well as other sensory stimuli, perceived odor intensity increases as a power function of concentration. At present, only sensory methods using human subjects are available for measurements of perceived air quality. The study of the relationship between odor stimuli and odor sensation show that for individual chemical compounds the relationship between perceived intensity and concentration varies between odorants. As a consequence the change in perceived odor intensity due to the same relative change of the concentration varies between odorants.

#### **2.4 Trained and untrained panels**

Two different panel procedures may be used to measure the initially perceived air quality:

1. **Trained or calibrated panel:** when a panel has to be trained to evaluate perceived air quality in decipol, a reference that is easy to measure and to produce is required. The gas 2-propanone (acetone) was selected through a literature survey and laboratory tests, it was found to be the best candidate since it is cheap, common and readily available. The



production is based on passive evaporation and is introduced to the human nose by a constant airflow coming out of the so called decipolmeter. Before 2-propanone can be used as a reference, a relation between the perceived air quality in decipol and the 2-propanone concentration in air is required. This relation can be used to train people in evaluating air quality directly in decipol.









2. Representative panel (untrained panel): this panel needs no training. It assesses the air quality by voting on acceptability and intensity scales shown in Figure (2.1).

Representativeness of this kind of panel is important. The panel size depends on the required precision of mean votes. The panel members rate odor intensity and assess acceptability immediately after sniffing the air. One disadvantage of using an untrained panel is that the performance of the panel cannot be evaluated.

The reason for using a trained panel instead of an untrained panel is that a trained panel requires less people than an untrained panel. It was found that in order to establish the same standard error on a mean vote with an untrained panel as a trained panel, at least 8 times as many people are needed (Bluyssen 1991). Both ASHRAE (1989) and European concerted Action (1992) suggest the use of untrained 'visitors' as judges due to the occupant's diminishing response to odors over time.

Gunnarsen & Bluyssen (1994) conducted a study to compare the performance of representative panels (vote either on a binary acceptability scale or on the continuous acceptability scale (figure 2.1)) and trained panels (vote in decipol scale) for initial assessment of air quality. They concluded that if an untrained panel is applied to evaluate perceived air quality in buildings, it should consist of 50 members minimum, when voting perceived air qualities in the typical range of 0-10 decipol, to be as precise as a

**Figure 2.1 Voting scale and questions usually used with the representative panel**

Vote for odor intensity	Vote for accept
How strong is the odor in this room ?	Imagine that you frequently during
Please mark on the scale :	daily work were exposed to the
	odor in this room . Would you
1  No odor	judge the odor as acceptable
2  Slight odor	<input type="checkbox"/> Acceptable
3  Strong odor	<input type="checkbox"/> Not acceptable
4  Very strong odor	How acceptable do you find
5  Overpowering odor	the odor ? please mark on the
	scale.
	1  Clearly acceptable
	Just acceptable
	0  Just not acceptable
	Just not acceptable
	-1  Clearly not acceptable
	Clearly not acceptable

trained panel of 12 members. The choice of panel depends on the required accuracy at expected pollution levels and the available equipment.

Reinikainen (1993) conducted a study on the effect of humidification on perceived indoor air quality assessed by untrained odor panel with 18-20 members. Before entering the building the panelists received a questionnaire inquiring the quality of outdoor and indoor air. They were asked to evaluate the perceived odor (using the same voting scale shown in figure 2.1) plus a scale to evaluate stuffiness (1=very fresh, 2= fresh, 3=neutral,

4=slightly stuffy, 5=stuffy). The results showed that an untrained panel of about 20 members can reliably differentiate a slight malodor and stuffiness in indoor air.

Oseland et al. (1994) developed a procedure for testing buildings by using a trained panel of people to rate air quality directly in decipol. 50 people were exposed to 8 unknown concentrations of acetone. The 17 people who gave the closest answers to the correct concentrations were selected to be trained as panel members. The panel members who were selected became capable of detecting and rating very low concentrations of acetone. The aims of the training were two folds: to ensure each panel member was competent in assessing samples of acetone, and to ensure consistency across the panel when assessing samples other than acetone. As the only difference between these samples was their concentration, the panel learnt to use intensity rather than annoyance to make their assessment. When the panel were presented with samples other than acetone, the assessments needed to be made considering annoyance, not intensity and the rating become much more varied. It was concluded that there were practical limitations with the procedure drawn up to test air quality in buildings using trained panels of people. Because of the cost of this technique and the practical difficulties associated with it, it is hard to see the technique being widely used in the future.

Berglund et al (1990) in their report about the sensory criteria for healthy building aimed to furnish judgmental criteria for defining a healthy building from a sensory effect point of view and to discuss requirements on methods of testing the sensory effects. They mentioned that the typical tool for scaling sensory effects in occupied buildings is the questionnaire surveys from which dose-response relationships may be constructed.

Pejtersen et al. (1993) studied the performance of a trained sensory panel, 15 subjects

were selected and trained for 14 hours in how to assess perceived air quality in the sensory unit decipol. The 2-propanone gas was used as a reference gas. In addition to the training with the reference gas the panel was exposed to air polluted with materials from buildings and ventilation systems. They concluded that it is important to make a careful selection of the subjects by a proper entrance test in order to obtain accurate and reproducible results from a trained sensory panel. They found for a panel of 15 subjects the standard error of the mean assessment of air samples polluted by various building materials increased from 0.4 decipol at a mean vote of 2 decipol to 1.3 decipol at a mean vote of 10 decipol.

A strategy was given by Bluyssen et al. (1995) on how to produce different concentrations of the reference gas to be used to train panels in evaluating perceived air quality directly in decipol. The equipment required to train a panel comprised 12 decipolmeters equipment for production of 2-propanone, a zero-decipol room and several forms to be filled by the panel members. It was found that the relation between the 2-propanone concentration and the perceived air quality could be used to train people to evaluate air quality directly in decipol. A critical point in the use of the decipolmeter is the establishment of the low values i.e. values below one decipol. Recommendations to establish an accurate and stable concentration using decipolmeter were given.

## **2.5 Adaptation**

The sense of smell, more than other modalities, is affected by adaptation as a result of fatigue from continued exposure to a stimulus. Exposure to an odor may cause adaptation and thus reduce both its perceived intensity and its quality but without its

disappearing altogether (Engen, 1982). There are several aspects of adaptation:

- Self adaptation means that the same substance was used as the adapting stimulus and as the test stimulus.
- Cross adaptation: when adapting stimulus having a different quality than the test stimulus.

Gunnarsen (1990) studied the adaptation to air pollution originated from typical building materials and its influence on the ventilation rate. A panel of 11 trained subjects was exposed to the pollution in climate chambers; the exposure lasted 16 minutes. The results showed a slight improvement in the acceptability of polluted air during the first minutes of exposure. He concluded that adaptation improves acceptability considerably when humans pollute the air, and some improvement occurs when moderate tobacco smoking is the pollution sources, while only a small improvement is observed when building materials are the main source of pollution. It was found that the most important factor to be considered when designing ventilation for acceptable air quality is pollution from building materials. Another research was conducted by Gunnarsen &Fanger (1992) about the adaptation to indoor air pollution, the purpose of this research was to study discomfort caused by typical indoor pollution before, during, and after a transient period of adaptation. 32 subjects served as air quality judges during 42 exposures. They were exposed to different concentrations of human bioeffluents, tobacco smoke, and emissions from building materials. The panel subjects voted every two minutes on scales for odor intensity and acceptability of the air quality while they were exposed to constant levels of air pollution. The results showed the positive and negative effects of cross adaptation. It was found that the air is perceived least acceptable immediately after people entering a

space with air pollution, and after some minutes people may adapt and the air is felt more acceptable, although the acceptability improvement due to adaptation depend on the source of air pollution (bioeffluent, tobacco smoking, building materials) which correlate with the results obtained in the previous study (Gunnarsen 1990). They concluded that ventilation for comfort may be reduced considerably if a few minutes of discomfort are acceptable or if the occupants are exposed to a gradually increased pollution level during the first 10 min. or more of their stay in a space.

Cain (1985) presented a model for the time course of olfactory adaptation to single components. He found that perceived intensity reaches a stable level of approximately 40% of the initial magnitude after 3 min of adaptation.

Adaptation, arising from continuous exposure, can affect olfaction, producing a reduced response which can result in lower perceived odor intensity. Studies conducted to date show that adaptation varies with the type of pollutant; of special interest are pollutants due to construction materials.

## **2.6 The effect of indoor-climate-related parameters on the emission from building materials:**

Physical and Psychophysical measurements of odor were performed by Cain et al (1983) to examine ventilation requirements during smoking and nonsmoking occupancy in an environmental chamber. They compared the impressions of visitors with impressions of occupants. For nonsmoking occupancy, 47 combinations of temperature, humidity, ventilation rate and occupancy density were examined. The main conclusion was that for both smoking and nonsmoking conditions, a combination of high temperature (25.5 °C)

and relative humidity (> 70%) exacerbated the odor problem.

Gunnarsen et al. (1993) studied the influence of specific ventilation rate on the emissions from construction products. The experiments were performed using small-scale climate chambers including CLIMPAQ, 4 construction products were tested. A trained sensory panel voted on decipol scale and chemical analysis quantified the major pollutants. The results showed that for low ventilation rates the emission rates may be proportional to the specific ventilation rate and for higher ventilation rates the emission rates become independent of ventilation.

Reinikainen (1993) evaluated the effect of humidification on odor perception, acceptability, and stuffiness of indoor air. The quality of indoor air was assessed by untrained odor panel. It was concluded that both perception of unpleasant odor and stuffiness increased when the air was humidified, and humidified air was less acceptable than nonhumidified.

Iwashita et al. (1994) examined the effects of the surface air velocity on surface emission of perceived air pollutants using 4 small chambers. Four different levels of surface air velocities were assigned to the four chambers. Four different materials were tested. The surface emission rate was calculated from the mean perceived air quality in decipol voted by trained panel. The results showed that the higher the surface air velocity the greater the surface emission rate of perceived pollutants, and it was recommended to keep the surface air velocities in a range found indoors in evaluating emission rate from building materials.

Bluvssen et al. (1996) described experiments on the effect of temperature on the chemical and sensory emission of indoor materials. Four materials were investigated and each

material was tested under two different temperatures. It was concluded that temperature has a significant influence on the chemically measured emission rate, but temperature did not influence the sensory emission significantly during two weeks. Also the chemical decay of TVOC emission proceeds faster than the sensory decrement.

L. Fang et al. (1996) studied the sensory response to air polluted by five building materials under different combinations of temperature and humidity. They concluded that the temperature and humidity have a strong impact on the perception of air polluted by five common materials while the impact on emission was less significant, and the impact of temperature and humidity on perception decreases with increasing level of air pollution.

In a research conducted by Wolkoff (1998) the emission of two volatile organic compounds of concern from five building products were measured in field and laboratory emission cell (FLEC). Ten different climate conditions were tested. The VOCs selected to be below human odor thresholds. The results showed that primary source emissions were not affected by the air velocity after a few days to any great extent. Both the temperature and relative humidity affected the emission rates, but depend strongly on the type of VOC and the type of building product.

In order to characterize a building product properly, it is important to know how various climate parameters may affect the perceived air quality and the emission rates of VOCs. Several parameters should be considered, including the air velocity over the building product, the age of the building product, temperature, and humidity.



## **2.7 Sensory VS non sensory techniques to evaluate indoor air quality**

Non-sensory methods have so far proved unsuccessful in determining odor and mucosal irritation. Recent studies have mostly shown that, for different VOC mixtures, there is no consistent relationship between concentration and odor intensity. While, for a given odorant or irritant, the perceived intensity will increase with increase in chemical concentration, different substances with the same concentration will elicit different perceived intensities. It would thus be useful, in addition to sensory methods, to employ VOC measurements in assessing air quality since VOCs are major pollutants, potentially odorous, and perceptible by the human nose (ECA-IAQ 1997). The overall odor strength of an indoor air sample was shown to be predicted simply from the number of components most frequently reported to have a strong odor (Berglund et al 1982).

The aim of the research conducted by K. Villberg et al. 1998 was to compare the results obtained from the test of 29 construction materials using chemical and sensory methods.

They found that TVOC did not correlate with sensory evaluations, the value of TVOC might be at a high level and the result of sensory evaluation is good. Instead the nature of the chemical groups (e.g. carbonyl compounds) are more relevant in characterization of odors, when the content of carbonyl compounds is high even though the TVOC is low, the odor is probably unpleasant.

## **2.8 Conclusion**

Despite the extensive research presented above (a summary of these efforts is shown in table 2.1), many questions concerning perception and emission of indoor air pollutants remain unanswered. The following challenges are presently facing researchers

in the area:

- The development of standardized measuring methods and models for emissions from indoor air pollution sources in chemical and sensory terms depending on age, air pollution concentration, air velocity, temperature and humidity.
- The development of models to predict perceived air quality in actual buildings from data obtained in the laboratory. Comparing such predictions with established standards would provide the criterion for labeling or classification of the material.
- The need for improving the level of measurement (scales) in sensory evaluations, while scales determine the type of statistical analysis that is adequate for the obtained measurements.
- The validation of innovative techniques, such as the use of trained panels to assess indoor air quality in decipol.
- The need for more fundamental knowledge about the behavior of indoor pollution sources to be able to reduce ventilation requirements and health hazards due to bad air quality.

This study will provide valuable information about the effects of varying ventilation on perceived air quality. The results could form the basis for computer modeling which help to predict indoor air quality in buildings and the most appropriate ventilation rates, taking into account the different sources of contamination and the need for an efficient use of energy.

**Table 2.1: Summary of some chemical and sensory tests conducted to date**

Researchers	Sensory test	Chemical test	pollution sources	Test facilities & conditions	Procedure	Objective/ Purpose of Experiment
H.N. Knudsen et al. (1997)	10-14 trained panel men and women mean age 25 years		Building materials: linoleum, PVC, floor varnish on beechwood, carpeting, wall paint, sealant	1030 L glass ventilated test chamber placed in a 28.5 m <sup>3</sup> environmental chamber of stainless steel outdoor-air exchange rate 40h <sup>-1</sup> the flow rate to the test chamber 1.8 L/s	The study was performed over a period of 11 weeks: two weeks with an empty chamber, one week for each of the eight materials, and one week for the mixture of three materials. The sensory panel came once every week, and before the assessment the panel was retrained for one hour.	To study exposure-response relationship between the concentration of air pollutants and perceived air quality
L. Gunnarsen et al. (1992)	16 female and 16 male untrained panel, ages 18-30 years. they voted on odor intensity on a modified Yaglou scale		Human bioeffluent tobacco smoke and building material	Two stainless steel chambers the volume=28.5 m <sup>3</sup> Air exchange rate 50 h <sup>-1</sup> Flow rate 1000 L/s	Adaptation to bioeffluent, adaptation to pollutants from building materials, adaptation to tobacco smoke & cross adaptation between the pollutants were studied. Each experiment lasting 4 h performed on four different days. Every 15 min a group of subjects entered a chamber and seated for 15 min. they voted on air quality just after entering and every 2 min.	To study discomfort caused by typical indoor pollution before, during and after a period of adaptation.
P.M. Bluysen et al.(1993)	10 trained panel and 8 untrained panel		Building materials (carpet, chipwood, linoleum, hardboard) newspaper and 2-propanone	Decipolmeters located in a climate chamber. Teflon bag (50L) to collect air samples from the outlet of the decipolmeter.	One week before the study, the selected materials were placed in decipolmeters. One hour before each test the small ventilators of the decipolmeters were activated. The perceived air quality produced by the decipolmeters was evaluated twice by trained panel with a gap of 150min. Air samples collected in Teflon bag were used for the execution of the threshold method using a panel of 8 persons	To compare the threshold method with the decipol method

**Table 2.1 : ( cont'd) Summary of some chemical and sensory tests conducted to date**

Researchers	Sensory Test	Chemical test	pollution sources	Test facilities & conditions	Procedure	Objective/ Purpose of Experiment
G. Iwashita et al. (1990)	107 representative panel (52 women and 27 men )		Bioeffluents from 54 occupants: 27women 27men	16.9 m <sup>3</sup> test chamber mean air temperature 25°C , relative humidity 43%	The panel occupied a well ventilated waiting room. The panel inhaled air from chamber through a sniffing opening. Immediately after sniffing the air they rated odor intensity on Yaglou's scale and assessed acceptability. The air exchange rate and the time of occupation were varied, three different situations were tested and for each one the panel was asked to evaluate the air quality.	To investigate indoor air quality by making subjective assessment of perceived air pollution caused by human bioeffluent
H.N. Knudsen et al. (1993)	15 trained panel		Synthetic carpet, linoleum, paint and sealant	51 L and 1030 L small scale test chambers made of glass and two 28.5 m <sup>3</sup> full-scale stainless steel environmental chambers one of them contained the small chambers. ACH 2 h <sup>-1</sup> temperature= 22°C, air flow rate 0.9l/s for small chambers	The experiments took five days: one for empty chambers and one for each of the four materials. The sensory panel assessed the perceived air quality in the full-scale chamber and in the diffuser furthermore the quality of air leaving the small chambers through diffusers were assessed.	To evaluate whether it is possible to predict the perceived air quality in a space based on experiments in small-scale test chambers.
L.Gunnarsen (1990)	11 trained panel		Six set of building materials	Two identical climate chambers	Six set of building materials were tested in three days. Each experiment day last one hr: 13 min exposure to one material, 30 min pausing then 16 min exposure to another material.	To study the adaptation to air polluted by building materials

**Table 2.1 : ( cont'd) Summary of some chemical and sensory tests conducted to date**

Researchers	Sensory Test	Chemical test	pollution sources	Test facilities & conditions	Procedure	Objective/ Purpose of Experiment
H. K. Hudnell et al.(1990)	66 trained panel ( male nonsmoker) mean age 25 years		Mixture of twenty two VOCs	Controlled environmental chamber	Subjects practiced each of the tests under clean air conditions in a training session. Experimental session were 4 hrs in duration: 75 min clean air, during the next 30 min VOC conc. was brought to target level. 2.25hrs was the time of exposure. Subjects indicated the intensity of irritation using potentiometer.	To study the odor and irritation effects of a mixture of VOCs
G. Iwashita et al. (1994)	Trained panel of 12 judges (8 female and 4 males).		Building materials: chipboard, carpet, rubber, and straw-mat	Four box-size small chambers, made of aluminum panel 40.5 l each four level of air velocity: 0.05,0.5,1.0 and 2.0 m/s ACH 41.2h <sup>-1</sup> temperature= 22°C, R.H.= 40-60%	As soon as the panel arrived at the box chambers they were requested to evaluate perceived air quality in decipol twice a day. Only one material was tested in each experimental day. Each material placed in the chamber and ventilated for 18 hrs.	To investigate the effect of the surface air velocity on surface emission rate of perceived air pollutants.
N. Parine et al. (1994)	300 office workers		Bioeffluent & Building materials	Two air- conditioned buildings mean temperature: 22.1°C -23.1°C R.H. 35-47% Fresh air ventilation : 10.8- 59.0 l/s.pers.	Four questions regarding air quality and odor were distributed to the workers in the buildings.	To find out whether the odor production by a building's materials is as important as the occupants odor production in determining the perception of air quality

**Table 2.1 : ( cont'd) Summary of some chemical and sensory tests conducted to date**

Researchers	Sensory Test	Chemical test	pollution sources	Test facilities & conditions	Procedure	Objective/ Purpose of Experiment
L.M. Reinikainen (1993)	18-23 members untrained panel more of half were men 20-49 yrs old		Bioeffluent, building material and ventilation system	The study was carried out in an office center (it has 6 symmetrical wings). RH in non humidified area 20-30% RH in humidified area 30-35%	The effect of air humidification was studied in six period. During these period the air humidification varied between the wings. The panelists did not know which of the wings was humidified. Each group entering the three wings in a random sequence, before that they received questionnaire to evaluate the quality of outdoor and indoor air.	To evaluate the effect of humidification on odor perception, acceptability and stuffiness of indoor air, and to test the ability of untrained panel to assess the characteristics of indoor air.
J. Pejtersen et al. (1993)	15 subjects trained panel (6 women & 9 men) mean age 30 yrs.		Building materials & ventilation system	Climate chamber with temperature = 22°C, air exchange rate= 8h <sup>-1</sup>	Before the panel assessed the air quality in a space they spent 2 min. in outdoor air to refresh the olfactory senses. The panel was instructed to assess the air quality immediately upon entering the space	To evaluate the performance of a trained sensory panel
P. Bluysen et al. (1996)	Trained panel	Air samples were collected with charcoal tubes and tested using GC and FID Identification was based on retention time	Four materials : carpet, oil-based paint, plywood board and a water-based paint	15 m <sup>3</sup> chamber covered with Teflon. Decipolmeter temperature 23°C air flow 15 m <sup>3</sup> /h air exchange rate 1.0h <sup>-1</sup> RH 45% air velocity at surface in center 0.1m/s. For chemical measurement: air flow rate= 1 l/min	For the sensory evaluations air was exhausted through one of the chamber wall to a decipolmeter. For each material two conditions were tested 23°C & 30°C so eight series of experiments were carried out.	To evaluate the influence of temperature on emissions from indoor materials both with chemical and sensory methods.

**Table 2.1 : ( cont'd) Summary of some chemical and sensory tests conducted to date**

Researchers	Sensory Test	Chemical test	pollution sources	Test facilities & conditions	Procedure	Objective/ Purpose of Experiment
L. Gunnarsen et al.(1993)	15 trained persons	Samples were taken on Tenax, desorbed by GC and quantified byFID	Linoleum, acrylic paint nylon carpet and sealant	5 CLIMPAQ , 3 FLECs, and two jar like 3 L glass chambers temperature 22°C air flow for sensory assessment 0.5 l/s	Each material was placed in the different chamber simultaneously and after 6 days chemical samples were taken and the sensory panel assessed the air quality each member assessed each test twice	To investigate the influence of air concentration of pollution expressed as ventilation rate per surface area on emission rates from construction products.
P. Wolkoff (1994)		A GC/MS analysis of the headspace of all tested materials	Carpet, paint and sealant	FLEC ( Field and laboratory Emission Cell)	The emission of VOCs from nine building products was measured in FLEC over a period of several months.	To test the long –term emission of VOCs from building products.
W.Cain et al. (1983)	165 persons		Smoking and nonsmoking occupants	Environmental chamber all surfaces were aluminum Floor surface 11 m <sup>2</sup> Flow rate 1000 L/s	Three levels of occupancy, four ventilation rates and four environmental conditions, forty seven combinations of these factors received attention. Some of the participants entered the environmental chamber(occupants) and other judge the odor at sniffing station	To rectify the lack of definite information regarding how both odor and notable contaminants from cigarettes will alter indoor air quality
P.O.Fanger et al. (1988)	54 persons : 27 men and 27 women age 18-30 yr.		Bioeffluent building materials and vent. system	Twenty spaces were selected for the study they had a minimum floor area of 60 m <sup>2</sup> , mechanically ventilated and none had a recirculation of the air	When the subjects entered a space they judged the air quality by filling a questionnaire about odor intensity and freshness in the same time measurements of physical and chemical factors were made	To quantify possible air pollution sources in the spaces and ventilation system based on olf unit

**Table 2.1 : ( cont'd) Summary of some chemical and sensory tests conducted to date**

Researchers	Sensory Test	Chemical test	Pollution sources	Test facilities & conditions	Procedure	Objective/ Purpose of Experiment
P. Wolkoff (1998)		VOCs were sampled on Tenax and determined by thermal desorption and GC/FID quantification was carried out by individual calibration of each VOC	Nylon carpet, PVC flooring, floor varnish, sealant and water borne wall paint	FLEC CLIMPAQ four different air velocities, three different temperature two different RH, pure N <sub>2</sub> supply instead of O <sub>2</sub> represent the different climate conditions	Ten different climate conditions were tested. The building products were preconditioned at 23°C in CLIMPAQs for 24 h before the FLEC start. The test specimens were tested in FLEC. Measurements were taken 24 h after FLEC restart for each test	To obtain information about the impact of important climate parameters on the emission rate of building products, in addition to identification of the emission mechanisms involved.
H.N. Knudsen & P.A. Nielsen (1997)	36 untrained panel assessed the immediate acceptability of air on the acceptability scale		8 materials : 6 floor covering 2 types of linoleum 2 types of sealant	CLIMPAQs Temperature 23°C RH 45% and air velocity 0.1 m/s Stainless steel dilution system was connected to The test chamber Q= 0.9 L/s (to test chamber & through diffuser)	The subjects assessed the perceived air quality for eight materials at different concentrations 3,10 and 29 days after the materials were placed in the chambers	To develop a method for determination of the exposure response relationships for emissions from building and furnishing materials.
L. Gunnarsen et al.(1994)	15 selected and trained panel each member assessed each test condition twice	Based on adsorption on Tenax and thermal desorption followed by chromatographic use of a flame ionization detector.	Carpet, linoleum, wall paint and sealant	3 CLIMPAQ chambers(50.9L) twin chamber (28.5 m <sup>3</sup> ) 1 m <sup>3</sup> glass chamber FLEC and 3L glass chamber All test were performed at 22°C	The same products were tested in different chambers After six days in the chambers chemical samples were taken and the trained sensory panel rated the air quality in decipol	To develop a simple test chamber capable of testing construction products in a climate where the important climatic parameters can be set independently at values found in typical buildings



## CHAPTER III

### EXPERIMENTAL SET-UP AND METHODOLOGY

#### 3.1 Chamber Description

The three small-scale test chambers built for this work were of the type CLIMPAQ (Chamber for Laboratory Investigations of Materials, Pollution and Air Quality) (Gunnarsen et al., 1994). They were made mainly of steel except their lids, which were made of glass. The volume of each chamber was 54.6 L, see Figure 3.1.

The interior surfaces were electropolished to insure against adsorption/ desorption effects. Each chamber was equipped with one internal fan recirculating air over the test specimens and driving the supply of fresh air. The exhaust air from each test chamber was led to a diffuser specially designed for sensory assessment (Bluyssen, 1990)

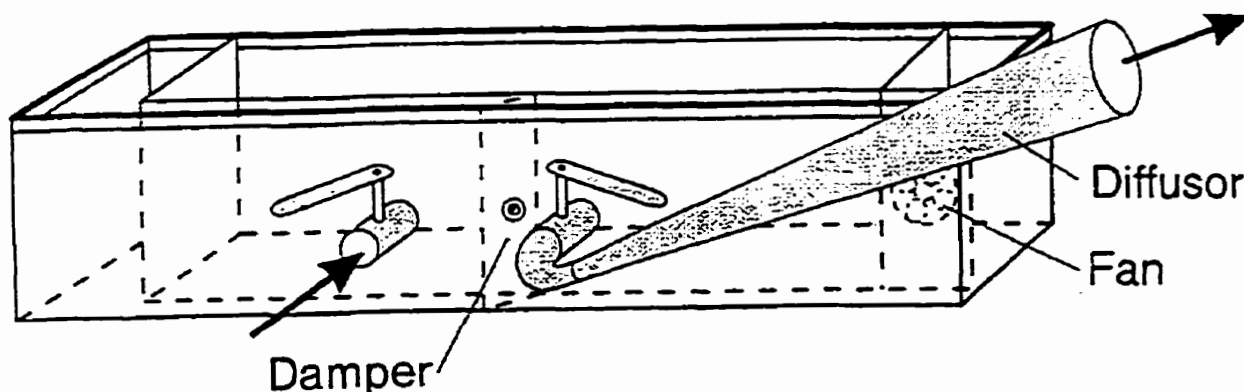

**Figure 3.1. The CLIMPAQ**

The three chambers were placed in a laboratory with high supply of conditioned outdoor air. The air inlets of the test chamber were connected to an air supply system taking air from the laboratory. The air supply for all the test chambers was filtered by a special filtration system (HEPA SHIELD filtration system). This system contains three different

filters: an antimicrobial throw-away polyester prefilter designed to remove larger particles, an activated carbon filter that removes most common odors and gases, and a HEPA filter which removes 99.97% of all particles 0.3 microns and larger. The experimental set-up is shown in Figure 3.2.

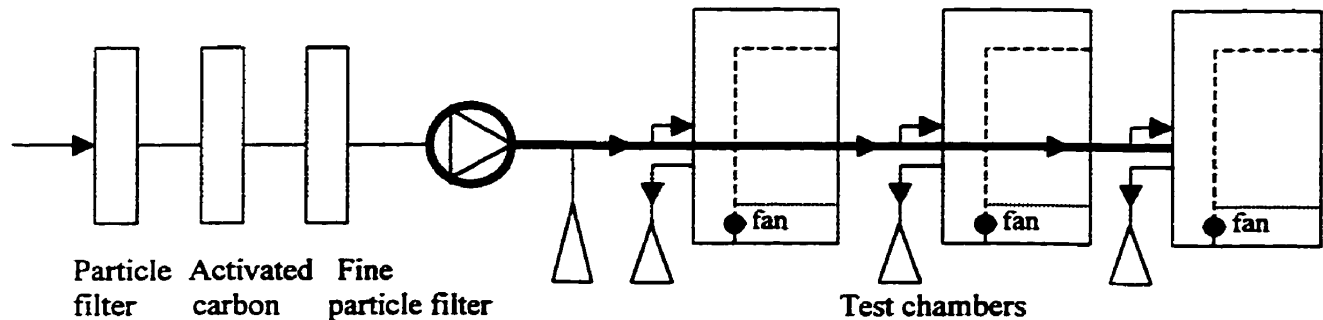

**Figure 3.2. The experimental set-up**

The flow rate of supply air to the test chambers and in the diffusers was kept at 0.9 l/s which is the recommended airflow for sensory study (Bluyssen, 1990; Clausen et al., 1995; Knudsen, 1994). The temperature and relative humidity in the test chambers were  $22\pm 1^\circ\text{C}$  and  $40\pm 5\%RH$ . During the experiments, the chambers were covered with aluminum foil to hide the tested materials from the view of the panel.

For the dilution experiments, an air dilution system was added to each chamber (Knudsen, 1998) and this dilution system consisted of stainless steel tubes with an inner diameter of 22mm (see Figure 3.3). Different degrees of dilution for the polluted exhaust air were achieved by mixing the test chamber air with different amounts of supply air. Supply air was the air in the lab after it has been passed through a filter. In these experiments the exhaust air from each test chamber was led through the dilution system before part of it reached the diffuser for sensory assessments.

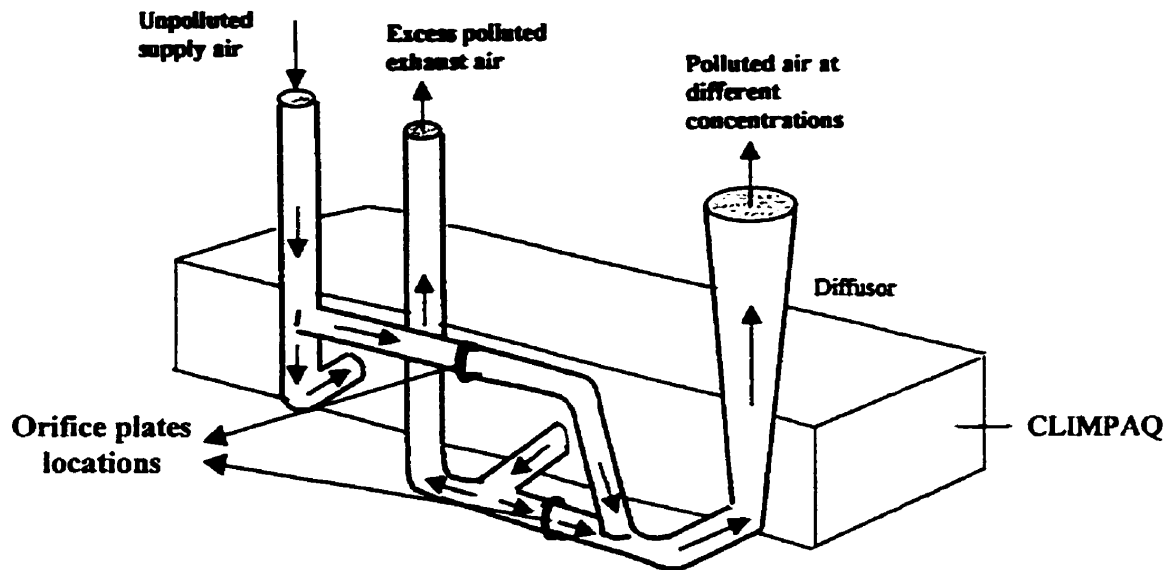

**Figure3.3. Dilution system**

The flow rates were adjusted by varying the diameter of the opening in two orifice plates made of Teflon. Five sets of orifice plates were prepared (see figure 3.4). One set provided undiluted exhaust air to the diffuser. By placing the other four sets, the concentration in the diffuser was diluted to  $1/2$ ,  $1/6$ ,  $1/9$ , and  $1/16$  of the concentration in the test chamber. A separate steel tube allowed the excess polluted exhaust air to escape to the outside when only a fraction of it was led to the diffuser.



**Figure 3.4. Sets of orifice plates used for the dilution**

Before each experiment the chambers were calibrated to ensure that the chambers had the same air exchange rate and the same airflow (0.9 l/s). For calibration procedure and resulted curves see Appendix I.

### 3.2 Building products

The five building products used in this study were selected to represent major groups of building products often used indoors. The tested building products were three floor coverings: two types of carpets, and one type of vinyl. Moreover, two types of water-borne wall paint applied onto 13- mm gypsum board were studied. See Table 3.1 for a description of the building products used in these experiments.

**Table 3.1. Tested construction products**

Vinyl	1.5 mm one –layer PVC
Carpet 1	8 mm nylon carpet with latex foam backing
Carpet 2	8 mm nylon carpet with rubber backing
Paint 1	White waterborne acrylic wall paint ( semi gloss, 10m <sup>2</sup> /L )
Paint 2	White waterborne latex wall paint ( 10 m <sup>2</sup> /L )
	Both of them were applied by a paint roller on both sides of 13-mm gypsum board with roll twice using 0.1 L/m <sup>2</sup> .

The size of the specimens placed in the test chamber was determined so that the area-specific ventilation rate, which is the ratio of the flow rate to the area of the building product, corresponded to the typical application of the building products in a standard model room 3.2 x 2.2 x 2.4 m ( length, width and height respectively) (17 m<sup>3</sup> volume).

This also takes into account the size of the test chamber (Clausen et al. 1995). Table 3.2 shows the sample areas of tested materials, the area specific airflow rate in the model room and the corresponding airflow rate and sample areas in the test chambers for the five experiments. The airflow rate was approximately 0.9 l/s for all the experiments.

**Table 3.2 Test conditions in the test chambers based on a model room with an air exchange rate of 2 h<sup>-1</sup>**

Experiment	Tested Materials	Model room		Test chamber (CLIMPAQ)		
		Surface area (m <sup>2</sup> )	Area specific airflow rate (m <sup>3</sup> /h/m <sup>2</sup> )	Sample area (m <sup>2</sup> )	Test specimen Number & Dimensions (m.m)	Airflow rate (l/s)
1,2 &3	Paint 1	24	1.42	2.24	8 pieces*: 0.7x 0.2	0.91
	Carpet 1	7	4.85	0.66	4 pieces: 0.68x 0.2 2 pieces: 0.28x 0.2	0.91
	PVC	7	4.85	0.66	4 pieces: 0.68x 0.2 2 pieces: 0.28x 0.2	0.89
4 &5	Paint 2	12	1.42	1.12	4 pieces : 0.7x 0.2	0.92
	Carpet 2	3.5	4.85	0.33	2 pieces: 0.6 x 0.2 2 pieces: 0.24x 0.2	0.92
	PVC	3.5	4.85	0.33	2 pieces: 0.6 x 0.2 2 pieces: 0.24x 0.2	0.93

\*8 pieces of gypsum board were painted on both sides

Experiment 1: intermittent ventilation, experiment 2: continuous ventilation, experiment 3: dilution. For the three experiments 100% of the model room walls assumed painted and 100% of the floor surface assumed covered by carpet or PVC.

Experiment 4: dilution, each CLIMPAQ contained one single material. Experiment 5: dilution, each CLIMPAQ had a mixture of two materials. For experiments 4&5: 49% of the model room walls assumed painted and 50% of the floor area assumed covered by carpet or PVC.

All the building products were new. Immediately upon purchase the materials samples

were prepared. The flooring materials were cut to the required size and wrapped in aluminum foil till the time of the experiment. The gypsum board pieces were painted on both sides with a painting roller twice using  $0.1 \text{ L/m}^2$  per time, and allowed to dry for 24 hrs before they were wrapped in aluminum foil. Few days before each experiment, samples of each of the flooring materials were stapled together, back-to-back to eliminate emissions from their backsides. They were placed vertically, in parallel with the length of the test chamber, while samples of wall paint on gypsum board were placed horizontally with one-cm interval between the samples. See Figure 3.5.

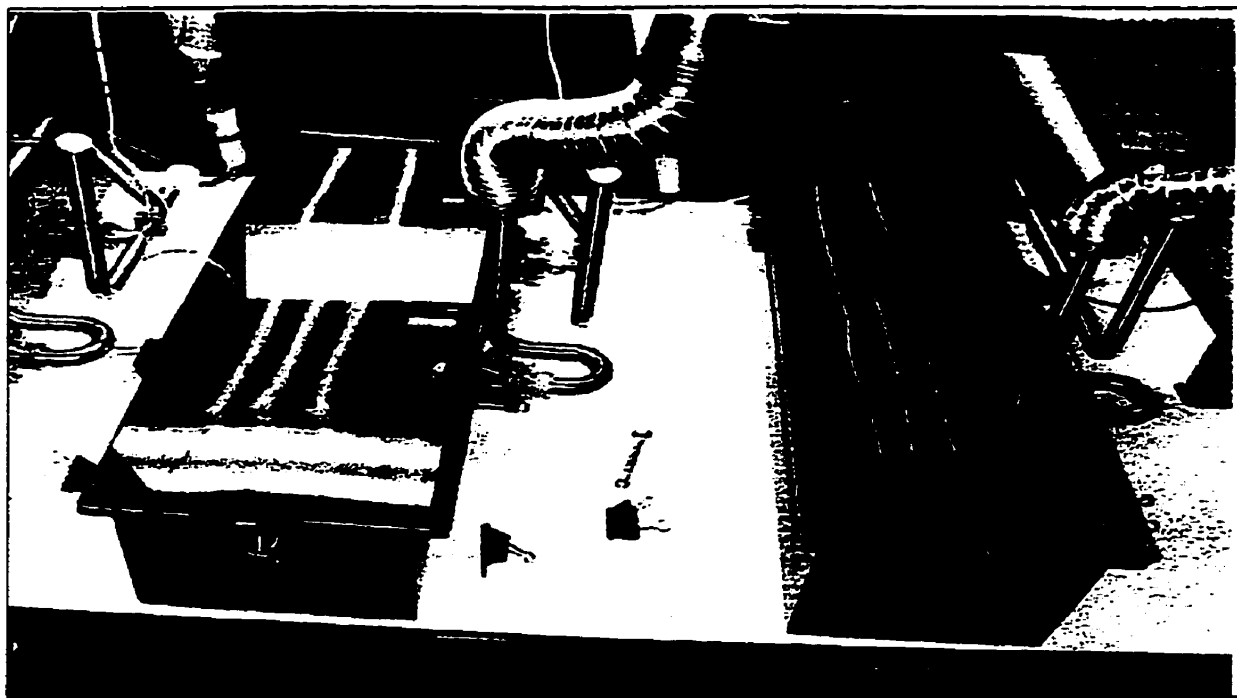

**Figure 3.5. PVC& carpet samples inside the test chambers**

### **3.3 Sensory Panels**

Untrained sensory panels comprising an average of 35 subjects performed the sensory assessment for all the experiments. The subjects were mainly university students whose age ranged from 21 to 43 years with a mean of 32 years. Approximately 72% of the participants were males and 21% were smokers. For more information about the

participating subjects, see Table 3.3. The panel assessed the immediate acceptability of the air from the diffusers and in real offices by marking on the acceptability scale shown in Figure 3.6. The subjects were also requested to evaluate the odor intensity by giving a number considering 10 is the odor intensity of the air in the laboratory where the test chambers were situated. The panelist exposure to chamber air was kept limited and they were asked to keep three minutes between assessments to minimize adaptation to chamber air. Before the assessment the panel was carefully instructed on how to use the scale, pointing out that focus should be on the initial perception, that no communication whatsoever on air quality is allowed during voting procedures, and that the scale should be considered continuous without categories. They were also instructed in how to use the exposure equipment. The assessments were done in random order. The panel instruction sheet used in these experiments is shown in Appendix IV.

### **3.4 Procedure**

Seven sensory tests were carried out. Continuous and intermittent ventilation strategies were tested as well as the impact of diluting the emissions from different building products on the perceived air quality. For each experiment, new samples of three building materials were placed in the chambers six days before the sensory assessments. Fans in the chambers and supply system were running either continuously or for twelve hours operation followed by twelve hours of no operation. Assessments were made four to eight hours after the onset of fans at 6 AM in the intermittent case. For all the experiments an untrained panel assessed the acceptability and odor intensity of the chamber air. Prior to each experiment, the three test chambers were cleaned with hot

water and a neutral detergent, and then they were rinsed with hot water and finally rinsed with distilled water. Moreover, the air quality in three unoccupied offices was investigated to study the impact of ventilation strategies on the indoor air quality. Each strategy was applied for six days before the sensory assessment. For intermittent ventilation scenario, the ventilation system was operated for twelve hours followed by twelve hours of no operation. Assessments were done on the last day, four to eight hours after the ventilation system started to work. For continuous ventilation strategy, the ventilation system was running continuously for five days before the panel assess the quality of the air on the day six.

### **3.5 Data handling and statistics**

Descriptive statistic (mean, standard deviation) was used to characterize the data. The mean acceptability and odor intensity votes were calculated using simple arithmetic means and the standard deviations were calculated to interpret the uncertainties. The 95% confidence limits were calculated to specify an interval within which the values of the mean will fall inside the calculated interval in 95% of occasions, but on 5% of occasions it will fall outside the interval. The limits are: the sample mean  $\pm 1.96$  (standard error) and the interval between them is called the 95% confidence interval. Calculations were performed with the Excel program. Statistical analyses were carried out in the form of ANOVA tests (Analysis of Variance). It allows testing the significance of the difference among two or more means. In principle, the difference between means is large and the variability within the groups is small, the result is likely to be significant.



Table 3.6. Acceptability and odor intensity voting sheet

Name: .....
Building: ..... Room: ..... Date:..... Time:.....
<p><b><u>I. Acceptability rating:</u></b></p> <p>During this test you are exposed to air which contains compounds usually found in office environments.</p> <p>How acceptable is the air quality ? Please mark on the scale:</p> <div style="text-align: center; margin: 20px 0;"> </div>
<p><b><u>2. Rating of odor intensity</u></b></p> <p>How intense is the odor in the air ? Choose a number, assuming the odor intensity in the lab is 10.</p> <p>The odor intensity is : <input style="width: 100px; height: 30px; border: 1px solid black;" type="text"/></p>

Table 3.3. Data for participating subjects

Experiment	Tested materials	Number of subjects	Mean age (years)	STDEVA Age(years)	Males %	Smokers %
<u>Ventilation strategies :</u>						
1. Intermittent ventilation (lab. test)	Paint1, Carpet1, & PVC	42	32	7	69	26
2. Intermittent ventilation (field investigation)	3 offices	35	28	5.5	77	17
3. Continuous ventilation (lab. test)	Paint1, Carpet1, & PVC	50	31	6	74	18
4. Continuous ventilation (field investigation)	3 offices	35	28	5.5	77	17
5. Dilution	Paint1, Carpet1, & PVC	29	32	6.5	72	21
<u>Additive effect of building materials:</u>						
6. Dilution (single materials test)	Paint2, Carpet2 & PVC	39	29	6	67	26
7. Dilution (combined materials test)	Paint2+Carpet2 Paint2+PVC Carpet2+PVC	34	29	6	71	26

## CHAPTER IV

### RESULTS

#### 4.1 Ventilation strategies

To study the effect of intermittent and continuous ventilation strategies on the perceived air quality two sets of experiments were performed: continuous ventilation and intermittent ventilation.

##### 4.1.1 Continuous ventilation experiment

Three materials were tested (Paint, Carpet, and PVC); they were placed in three CLIMPAQs and ventilated continuously for 6 days. On the last day a panel of 50 subjects assessed the immediate acceptability of the air. The panel members reported the acceptability and odor intensity of each chamber air and supply air on a voting sheet provided to the participating subjects at the beginning of the experiment. In the data analyses, numbers were assigned to the markings. «Clearly not acceptable » was assigned -10, and « Clearly acceptable » was assigned 10, with 0 being the midpoint and numbers in between were considered to lie on a linear scale. Moreover the panel assessed the odor intensity of the air from the diffuser using a ratio scale considering the air in the laboratory as a reference with odor intensity equal to 10. More intense odors should be given higher numbers and less intense odors given smaller numbers \*. A summary of the obtained results is presented in Table 4.1, and in Figures 4.1 & 4.2. The mean acceptability votes for the air quality assessed by a sensory panel of 50 persons, where a

---

\* For example, if the odor was twice as strong as the laboratory air, it should get the number 20. An odor of  $\frac{1}{4}$  the strength should be given a 2.5 etc.

**Table 4.1. Results of continuous ventilation experiment**

CLIMPAQ	Material	Acceptability			Odor intensity		
		Mean	95% Conf.		Mean	95% Conf.	
1	Carpet	-0.61	0.67	-1.89	22.32	26.14	18.5
2	Paint	1.61	2.99	0.23	17.20	19.6	14.8
3	PVC	-4.69	-3.45	-6.07	32.60	37.36	27.84
4	Supply	4.97	6.47	3.47	12.79	15.13	10.45

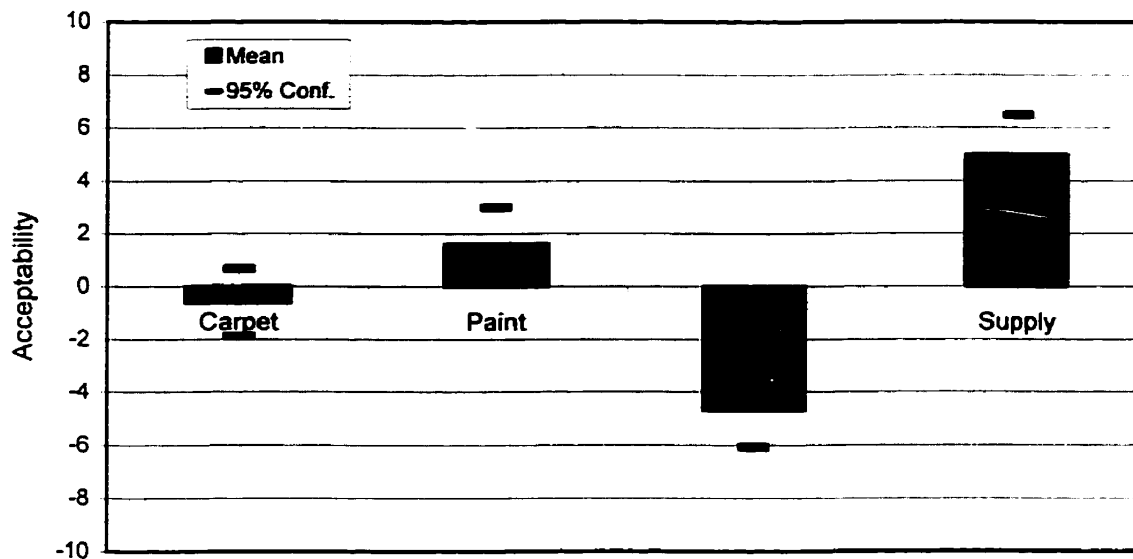
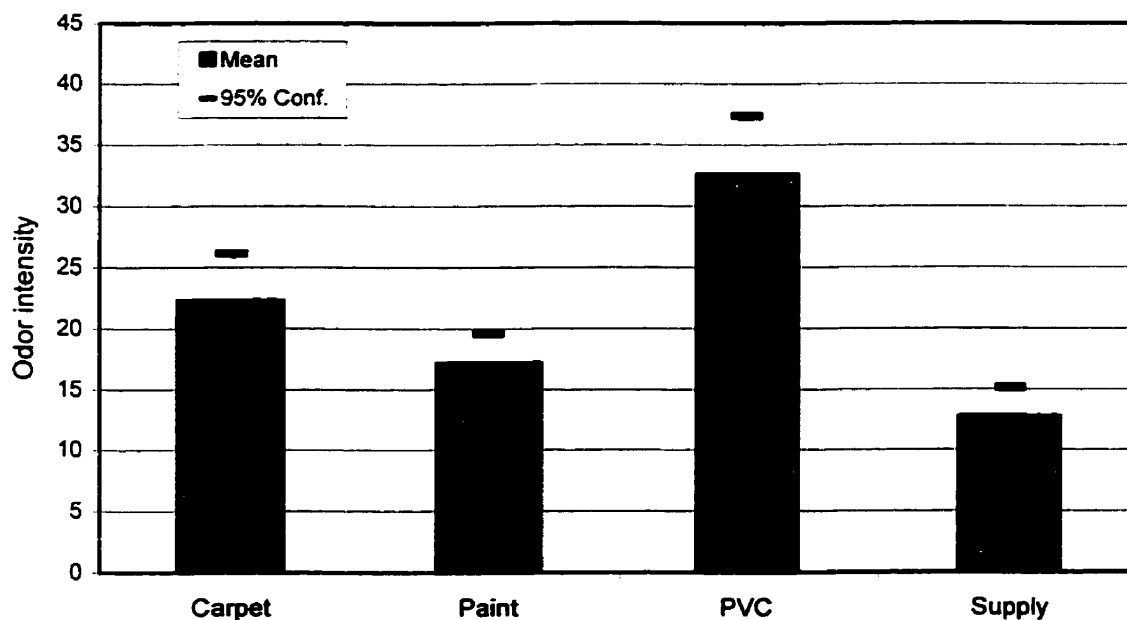
**Figure 4.1. Mean acceptability vote for continuous ventilation****Figure 4.2. Mean odor intensity vote for continuous ventilation**

continuous ventilation strategy was applied, is shown in Figure 4.1 together with the 95% confidence limits. The most acceptable among the tested materials was the paint with a mean acceptability vote equal to 1.6 and the least acceptable was the PVC with  $-4.7$  mean acceptability vote. The carpet was in between with a mean acceptability vote of  $-0.6$ . The highest acceptability mean was for the supply air and it was approximately  $+5$ . Mean acceptability votes were calculated using simple arithmetic means. Figure 4.2 shows the mean votes for odor intensity of the assessed air for the three tested materials and for the supply air. Again the highest odor intensity was 33 for the PVC then the carpet with odor intensity 22, and the odor intensity for the paint was 17. The odor intensity for the supply was approximately 13 which is still more than 10 (the reference) and this may be due to the slight odor emitted from the filter materials. The means and 95% confidence limits for odor intensity votes are shown in Table 4.1 and Figure 4.2. The air quality assessment results for each participating individual are shown in Appendix 2.

#### **4.1.2. Intermittent ventilation experiment**

In this experiment the air supply system and the fans in the chambers were operating for 12 hours followed by 12 hours of no operating. New samples of paint, carpet and PVC were placed in the test chambers six days before the sensory assessment. The acceptability and the odor intensity of chamber air were assessed by a panel of 42 subjects. The means and the 95% interval limits for the votes on acceptability and odor intensity are shown in Table 4.2. The mean acceptability votes for the assessed air quality for each test chamber and for the supply are shown in Figure 4.3. The most acceptable was the paint with a mean acceptability vote of  $-0.27$  and the least acceptable was the

PVC with a mean acceptability of  $-5.7$ . The carpet had an acceptability of  $-2.6$ .

The mean acceptability vote for the supply air was  $4.6$  and almost equal to the supply air acceptability when continuous ventilation was applied. The mean odor intensity votes for the three construction materials and for the supply air are presented in Figure 4.4. The highest odor intensity was for PVC and it was equal to  $36$ , the lowest was the paint odor intensity and it was equal to  $23$ . The odor intensity of the carpet was  $24$ , and  $13$  was the odor intensity of the supply air.

Results for each individual vote are shown in Appendix 2.

The obtained results from the two mentioned experiments were gathered in Figure 4.5 for acceptability and Figure 4.6 for odor intensity. The two figures show the positive impact of continuous ventilation on the perceived air quality in comparison with intermittent ventilation. The improvement differed from one material to another but always the air quality was perceived better when continuous ventilation was applied.

To test the differences among the means an ANOVA test was used. The results of acceptability assessment were the following:  $[F(1,29) = 6.961; P=0.013]$  for the effect of strategy,  $[F(3,87) = 68.848; P < 0.0001]$  for the effect of material and  $[F(3,87) = 0.357; P=0.7845]$  for the interaction between strategies and materials. Thus both strategies and materials produced significant variation. The odor intensity assessment results show the following:  $[F(1,29) = 6.474; P = 0.0165]$  for the effect of strategies,  $[F(3,87) = 33.243; P < 0.0001]$  for the effect of materials and  $[F(3,87) = 0.956; P = 0.417]$  for the interaction of materials and strategies. Thus the effect of strategies and materials was significant.

$P$  is the probability that the difference is due to chance and not to manipulation and is based on  $F$  and  $df$  where  $F$  is the ratio of the mean square between groups to the mean

Table 4.2. Results of intermittent ventilation experiment

CLIMPAQ	Material	Acceptability			Odor intensity		
		Mean	95% Conf.		Mean	95% Conf.	
1	Carpet	-2.55	-1.43	-3.98	24.12	29	19.24
2	Paint	-0.27	1.11	-1.65	22.88	26.46	19.30
3	Vinyl	-5.65	-4.35	-6.95	36.29	43.43	29.13
4	Supply	4.64	6.08	3.2	12.71	14.41	11.01

Figure 4.3. Mean acceptability vote for intermittent ventilation

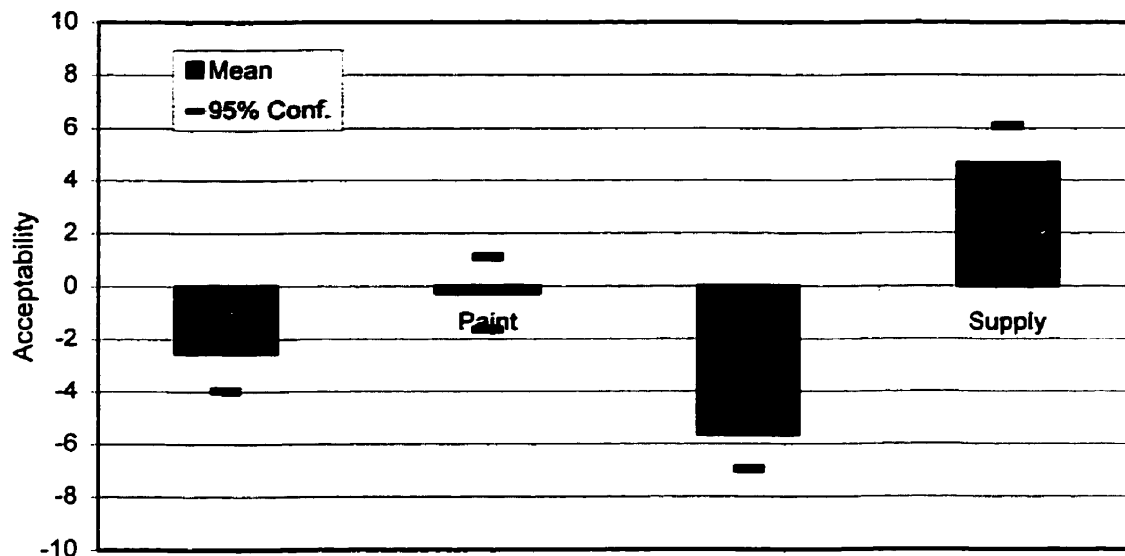
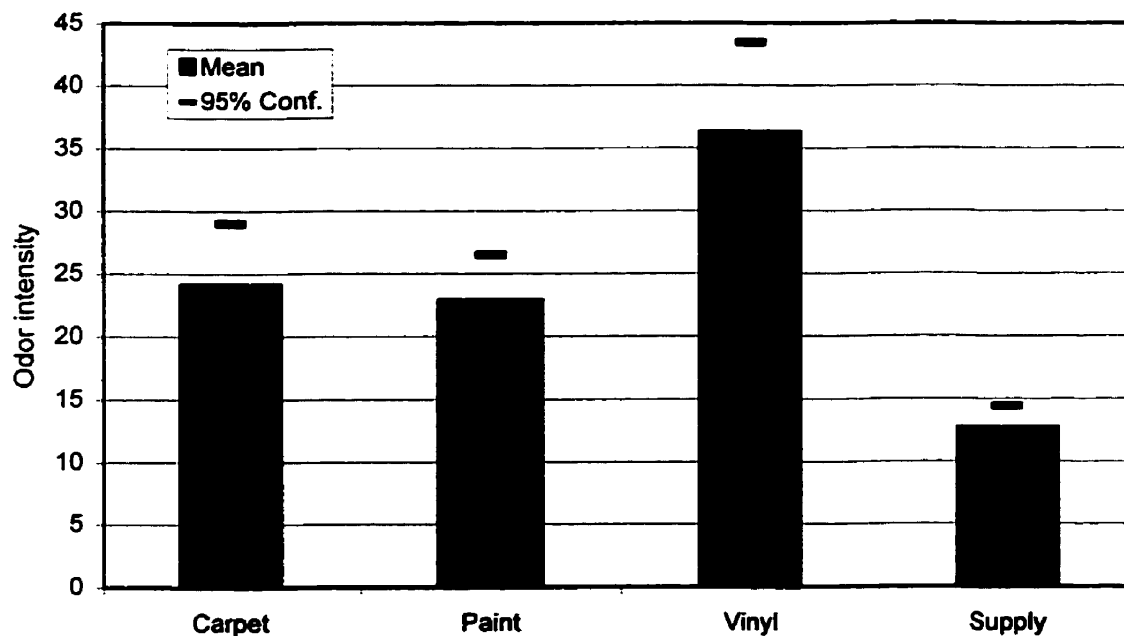
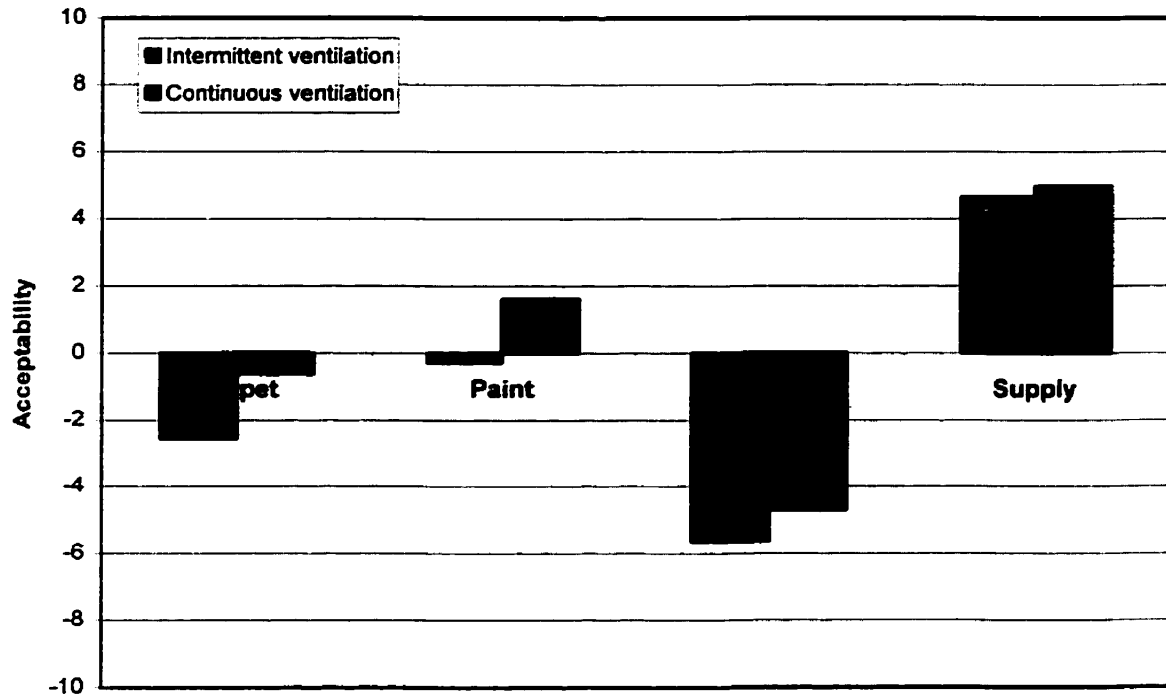

Figure 4.4. Mean odor intensity vote for intermittent ventilation



**Figure 4.5. Mean acceptability votes with continuous and intermittent ventilation**



**Figure 4.6. Mean odor intensity votes with continuous and intermittent ventilation**

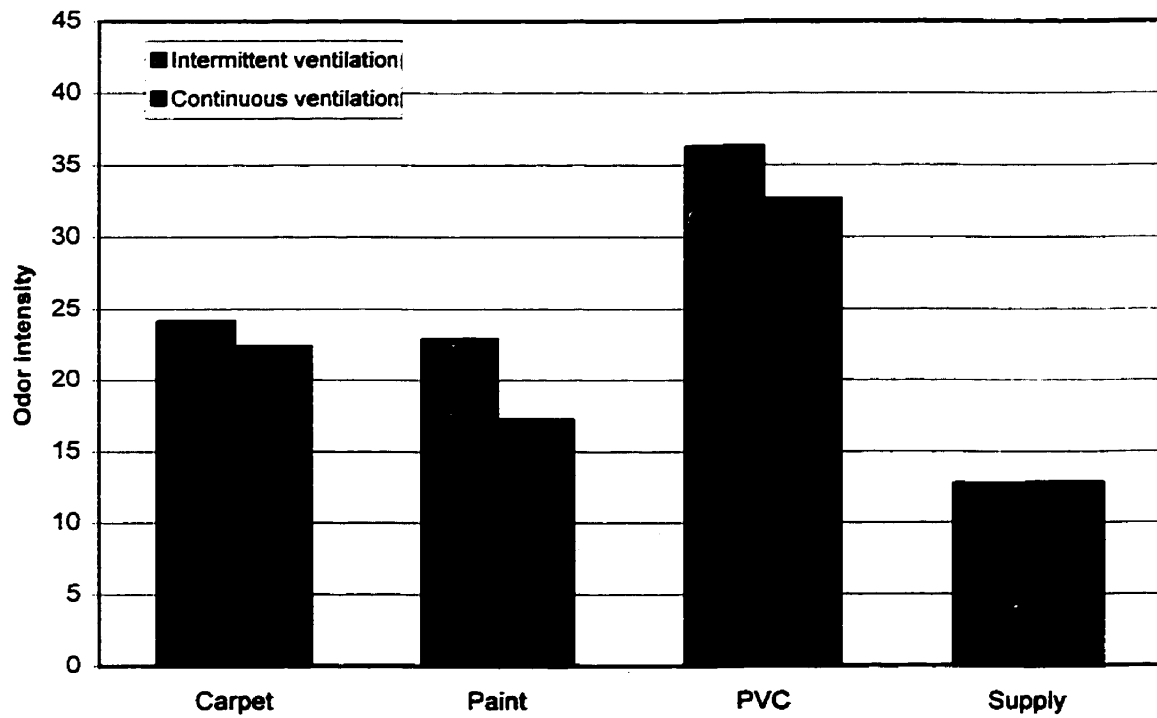



square within groups and df is degree of freedom. Both experimental results show that there is no interaction between the materials assessments for intermittent and continuous ventilation. For all the materials the perceived air was better when continuous ventilation strategy was applied. See figures 1&2 in Appendix 3

To know what differences between means are significant Tukey's HSD post hoc test was used. The results show that the differences among the means were statistically significant at  $P < 0.05$  for carpet and paint and at  $P < 0.01$  for PVC and that for each strategy. Differences between the two strategies were significant at  $P < 0.05$  for paint and differences were not significant for supply air.

#### **4.1.3 Dilution experiment**

To study the impact of diluting the contaminant concentration on the perceived air quality, the dilution experiment was performed. Three new samples from the same materials (paint, carpet and PVC) were placed in the test chambers and the exhaust air from each chamber was led through a dilution system designed to provide different concentrations of polluted air for sensory assessments. The samples were placed in the chambers three days before a panel of 29 subjects assessed the air quality in terms of acceptability and odor intensity for 5 different concentrations. A summary of the results is presented in Table 4.3. The mean acceptability vote as a function of the dilution factor is shown in Figure 4.7 for the three building products and for the supply air. The dilution factor is the ratio between the flow rate in the diffuser and the flow rate of polluted exhaust air from the test chamber. It is 1 at the highest concentration, i.e. undiluted. The concentration of chamber air was diluted approximately 2, 6, 9 and 16 times. The mean acceptability vote at the highest concentration varied from one material to another.

**Table 4.3 Summary of the dilution experiment results**

**Acceptability assessments**

Dilution	Acceptability									
	Paint		Carpet			PVC		Supply		
	Mean	Confidence limits	Mean	Confidence limits	Mean	Confidence limits	Mean	Confidence limits		
1	0.04	1.50 — -1.42	-1.53	-0.29 — -2.77	-4.63	-3.33 — -5.93	5.81	7.19 — 4.43		
2	0.70	2.22 — -0.82	0.13	1.59 — -1.33	-3.20	-1.78 — -4.62	5.95	7.23 — 4.67		
6	2	3.56 — 0.44	2.10	3.80 — 0.40	-0.89	0.85 — -2.63	5.19	6.69 — 3.69		
9	2.13	3.67 — 0.59	2.34	3.86 — 0.82	0.71	2.07 — -0.65	4.47	6.17 — 2.77		
16	2.43	3.83 — 1.03	3.12	4.78 — 1.46	2.56	4.26 — 0.86	4.99	6.77 — 3.21		

**Odor Intensity assessments**

Dilution	Odor intensity									
	Paint		Carpet			PVC		Supply		
	Mean	Confidence limits	Mean	Confidence limits	Mean	Confidence limits	Mean	Confidence limits		
1	21.82	25.42 — 18.22	25.29	31.59 — 18.99	32.04	39.44 — 24.64	11.81	13.69 — 9.93		
2	19	22.46 — 15.54	18.89	22.35 — 15.43	29.66	36.64 — 22.68	11.52	13.38 — 9.66		
6	16.13	19.03 — 13.23	14.33	16.65 — 12.01	21.13	27.23 — 15.03	11.85	13.39 — 10.31		
9	15.91	18.47 — 13.35	14.90	17.44 — 12.36	18.49	22.23 — 14.75	13.18	15.42 — 10.94		
16	14.45	16.81 — 12.09	13.63	15.85 — 11.41	15.16	18.18 — 12.14	13.13	15.45 — 10.81		

**Figure 4-7**  
**Acceptability as a function of dilution factor**

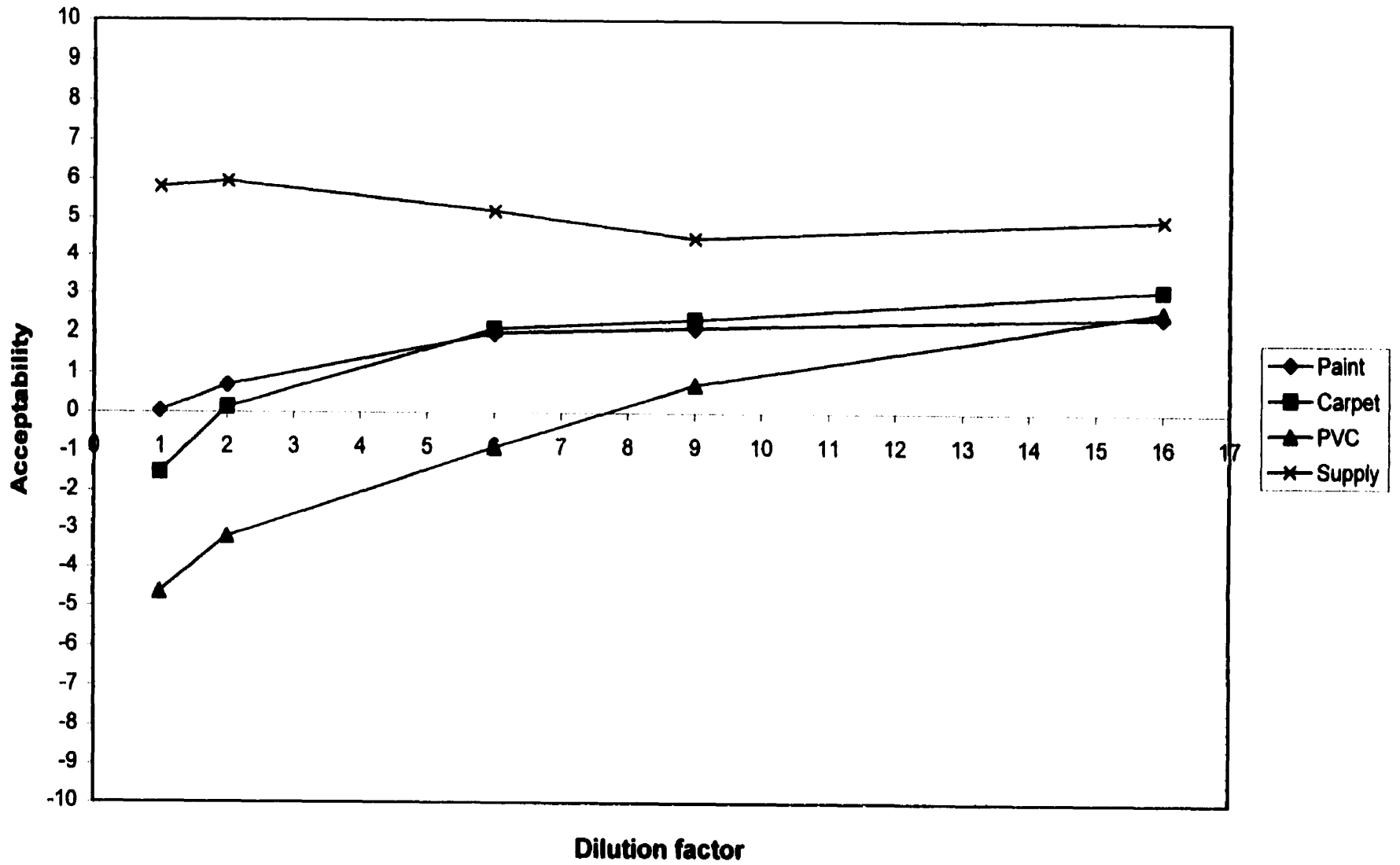

The most unacceptable was the PVC (mean acceptability vote was approximately -5) and the best was the paint (mean acceptability vote was near 0); the carpet was in between with -1.5 as the mean acceptability vote. The acceptability and odor intensity values at dilution factor = 1 should be repetitions of the assessments for continuous ventilation (Table 4.1). The samples in this experiment however, were conditioned in the test chambers for a shorter period (3 days instead of 6 days) which reduces the acceptability and increases the odor intensity for the assessed air. For all the tested materials the perceived air quality improved when the dilution of the chamber air increased. The improvement was most pronounced for PVC. When the polluted air was diluted 16 times the acceptability increased from -4.63 to +2.56, while for the paint the 16-fold dilution increased the acceptability from +0.04 to +2.43. The big improvement occurred when the polluted air was diluted between 1 and 6 times while there was just a small improvement between 6 and 16-fold dilution. For the carpet, the 16-fold dilution increased the acceptability from -1.53 to +3.12, and most of the improvement was between 1 and 6 fold dilution. The supply air acceptability varied between +4.5 and +5.9. A 16-fold dilution led to acceptability around +3 for all the tested materials. This was an improvement from the no dilution case. The panel, however, was able to distinguish between assessments of the chambers with material samples and the supply air despite the 16-fold dilution. The emission from the ducts and the chambers itself affect the perceived air quality and could explain the difference between the perceived air from the chambers and the one of the supply.

Figure 4.8 shows the relationship between the dilution and odor intensity and how the perceived odor intensity decreased when the dilution increased. The big improvement

Figure 4-8  
Odor intensity as a function of dilution factor

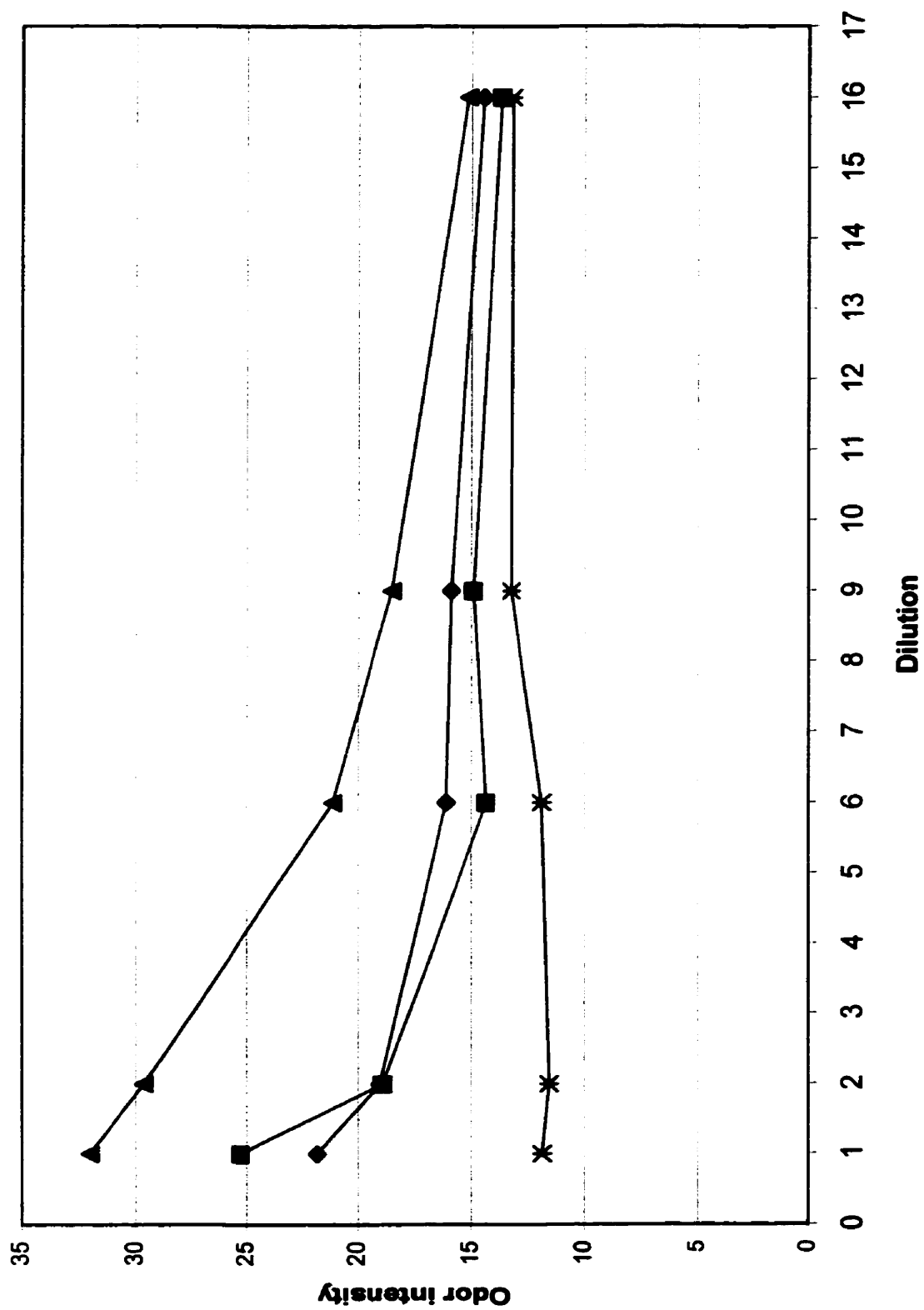

was with a dilution between 1 and 6 for all the tested materials and it continued to be moderate for PVC and relatively small for paint and carpet when the dilution increased from 6 to 16 times. When the chamber air from the three test chambers was diluted 16 times the assessments of odor intensity deviate only slightly from the assessments of the supply air. A summary of the results is shown in Table 4.3 and the detailed results of acceptability and odor intensity tests for each individual are included in Appendix 2.

Figure 4.9 shows the relationship between dilution factor and mean acceptability vote for paint, carpet, PVC, and air supply in a semi-log plot. The figure shows a linear relationship between acceptability and the dilution factor. The relationship can be described by the formula:

$$ACC = K_1 + K_2 \log (DIL)$$

Where ACC= mean acceptability vote as assessed by the sensory panel,  $K_1$ = constant characterizing the position of the line, i.e. the acceptability vote at the highest concentration,  $K_2$  = constant characterizing the slope of the line,  $\log (DIL)$ = logarithm of the dilution factor.

Statistical analysis, ANOVA was also performed to study the differences between the means. The results for acceptability and odor intensity assessments were significant. For acceptability: [F (3,84) = 48.619; P<0.0001] for the effect of materials, [F (4,112) = 18.688; P<0.0001] for the effect of dilution and [F (12,336) = 14.766; P<0.0001] for the interaction of materials and dilution. For odor intensity: [F (3,81) = 18.436; P<0.0001] for the effect of material, [F (4,108) = 20.628; P<0.0001] for the effect of dilution and [F (12,324)=8.334; P<0.0001] for the interaction of materials and dilution. The effect of dilution was significant for all the tested materials at P<0.0001.

Figure 4-9  
Exposure-response relationship

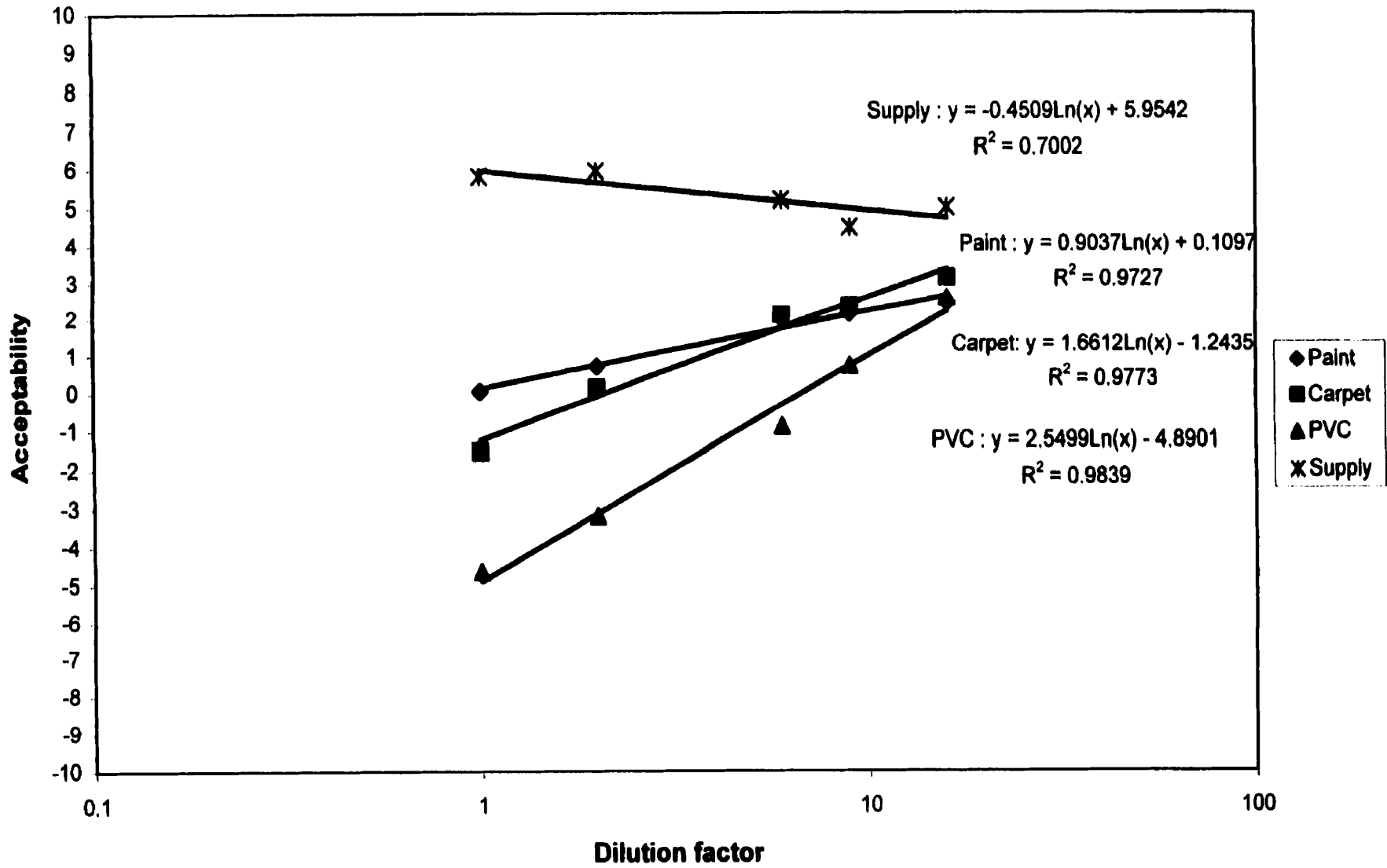

The ANOVA results for this experiment are presented in Appendix 3.

#### 4.2 Field measurements:

The air quality in three different offices located in different buildings was assessed for both continuous and intermittent ventilation strategies. For the intermittent scenario the ventilation was stopped for approximately 12 hours during the night and operated during daytime. For both experiments, a panel of 35 subjects assessed the air quality 6 days after the ventilation strategy was changed. The participating subjects were asked to evaluate the acceptability and odor intensity of the air immediately after entering the office. The results are presented in Table 4.4 and Figures 4.10 and 4.11. Figure 4.10 shows the mean acceptability vote for each office for continuous and intermittent strategies. Figure 4.11 shows the mean odor intensity for each office and each strategy. Both figures show the improvement of perceived air quality (better acceptability and less odor intensity) when a continuous ventilation strategy was applied in comparison with the intermittent ventilation strategy. These results are in accordance with the ones obtained in the laboratory although the difference between assessments at intermittent and continuous ventilation is less pronounced in this test.

ANOVA results show that the effect of ventilation strategies is less significant in this case than the one of materials in test chambers, since the strategies effect have given the following result:  $[F (1,27) = 3.558; P = 0.07]$ . For the interaction between offices and strategies we find  $[F (2,54) = 1.008; P = 0.3718]$ . This result means that for all the offices the air was perceived better when continuous ventilation was applied. See figure 3 in Appendix 3. The effect of ventilation strategy was significant at  $P = 0.01$  for office 1 and

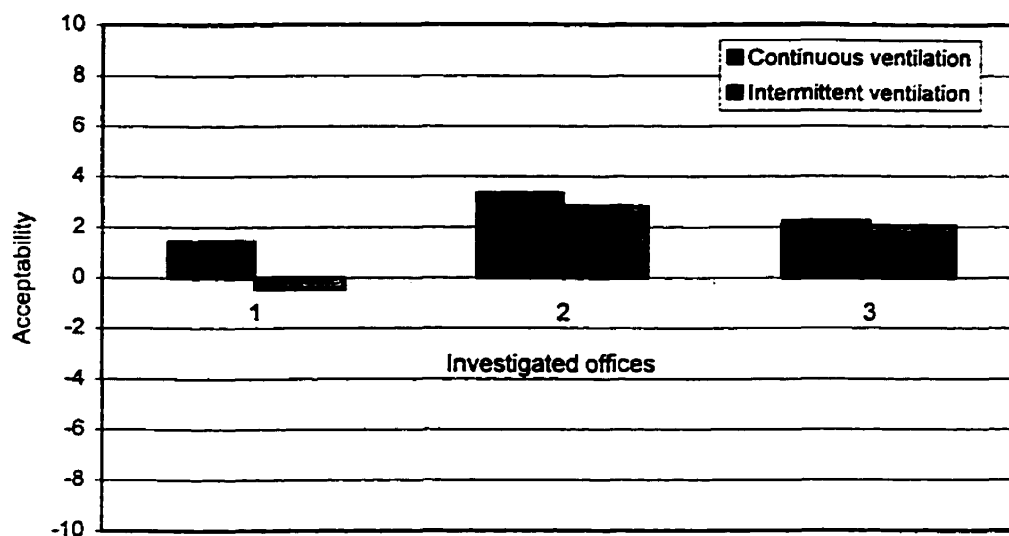
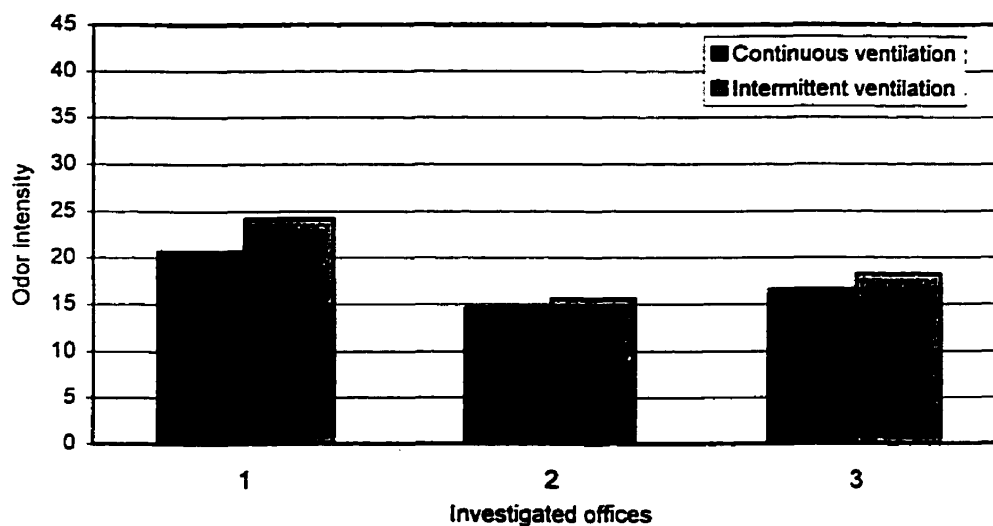

**Table 4.4. Results of the sensory testing carried out in real offices**

Continuous ventilation						
Office	Acceptability			Odor intensity		
	Mean	95% Conf.		Mean	95% Conf.	
1	1.42	2.70	0.14	20.64	25.30	15.98
2	3.33	4.73	1.93	14.62	16.66	12.58
3	2.23	3.67	0.79	16.55	19.27	13.83

Intermittent ventilation						
Office	Acceptability			Odor intensity		
	Mean	95% Conf.		Mean	95% Conf.	
1	-0.43	1.37	-2.23	24.18	31.32	17.04
2	2.81	4.13	1.49	15.56	17.54	13.58
3	2.04	3.40	0.68	18.21	22.45	13.97

**Figure 4.10. Mean acceptability votes at continuous and intermittent ventilation****Figure 4.11. Mean odor intensity votes at continuous and intermittent ventilation**

less significant for the offices 2 and 3 ( $P < 0.5$ ).

### **4.3 The additive effect of building products on the perceived air quality**

The effect of combining two materials on the perceived air quality was tested and compared with the case where only one material was present in each test chamber. For this purpose two dilution experiments were performed, in the first experiment single samples of paint, carpet and PVC were tested individually. They were placed in the test chambers 6 days before a panel of 39 subjects assessed the acceptability and the odor intensity of the air from the chambers through the diffusers in five rounds of sensory testing. In each round the concentration of the polluted air was changed using dilution system. The results of this test are presented in Table 4.5. Figure 4.12 shows the mean acceptability vote and the 95% confidence interval corresponding to each dilution factor for paint, PVC, carpet and air supply. The acceptability as a function of the dilution factor is shown in Figure 4.13 for the same materials all together. This figure allows the comparison between the behavior of the tested materials when different dilution factors were applied. At the highest concentration the acceptability vote differed from one material to another. The best was the paint (acceptability = -1) and the worst was the carpet (acceptability = -3). PVC had an acceptability of -1.4. The difference between these results and the ones obtained from the ventilation strategies experiment could be related to the tested materials. The materials used in this experiment were different from the ones used in the previous experiments (different kind of paint and different kind of carpet). The PVC was the same, but due to the aging effect the acceptability in this experiment was better than the one obtained in the ventilation strategies experiment.

**Table 4-5 Sensory assessment results for dilution experiment when each test chamber contained samples of one building product**

**Acceptability assessments**

Round	Acceptability											
	Paint			Carpet			PVC			Supply		
	Dil.	Mean	Confidence limits	Dil.	Mean	Confidence limits	Dil.	Mean	Confidence limits	Dil.	Mean	Confidence limits
1	16	2.39	3.62 – 1.16	1	-3	-2.06 – -3.94	9	2.2	3.60 – 0.80	–	1.8	3.34 – 0.26
2	9	2.36	3.80 – 0.92	2	-1.5	-0.17 – -2.83	1	-1.4	0.01 – -2.81	–	2.02	3.51 – 0.53
3	6	0.88	2.26 – -0.50	6	0.6	1.90 – -0.70	16	2.4	4.02 – 0.78	–	1.71	3.46 – -0.04
4	2	-0.82	0.57 – -2.21	9	0.9	2.47 – -0.67	2	-0.7	0.76 – -2.16	–	1.75	3.59 – -0.09
5	1	-1.07	0.50 – -2.64	16	2.2	3.79 – 0.61	6	1	2.72 – -0.72	–	1.78	3.65 – -0.09

**Odor intensity assessments**

Round	Odor Intensity											
	Paint			Carpet			PVC			Supply		
	Dil.	Mean	Confidence limits	Dil.	Mean	Confidence limits	Dil.	Mean	Confidence limits	Dil.	Mean	Confidence limits
1	16	15.1	17.21 – 12.99	1	32.2	42.54 – 21.86	9	16.1	20.53 – 11.67	–	17.4	20.26 – 14.54
2	9	15.3	17.32 – 13.28	2	23.3	27.26 – 19.34	1	23.8	26.41 – 21.19	–	17.4	21.17 – 13.71
3	6	19.9	24.29 – 15.51	6	20.8	26.43 – 15.17	16	16.1	19.91 – 12.29	–	18.1	21.19 – 15.07
4	2	24.6	30.17 – 19.03	9	20.1	23.78 – 16.42	2	22.5	27.37 – 17.63	–	17.8	21.02 – 14.60
5	1	25.9	31.73 – 20.07	16	16.9	20.77 – 13.03	6	18.7	21.38 – 16.02	–	18	21.96 – 14.06

**Figure 4.12.** Mean acceptability and 95% confidence interval when chamber exhausts were diluted

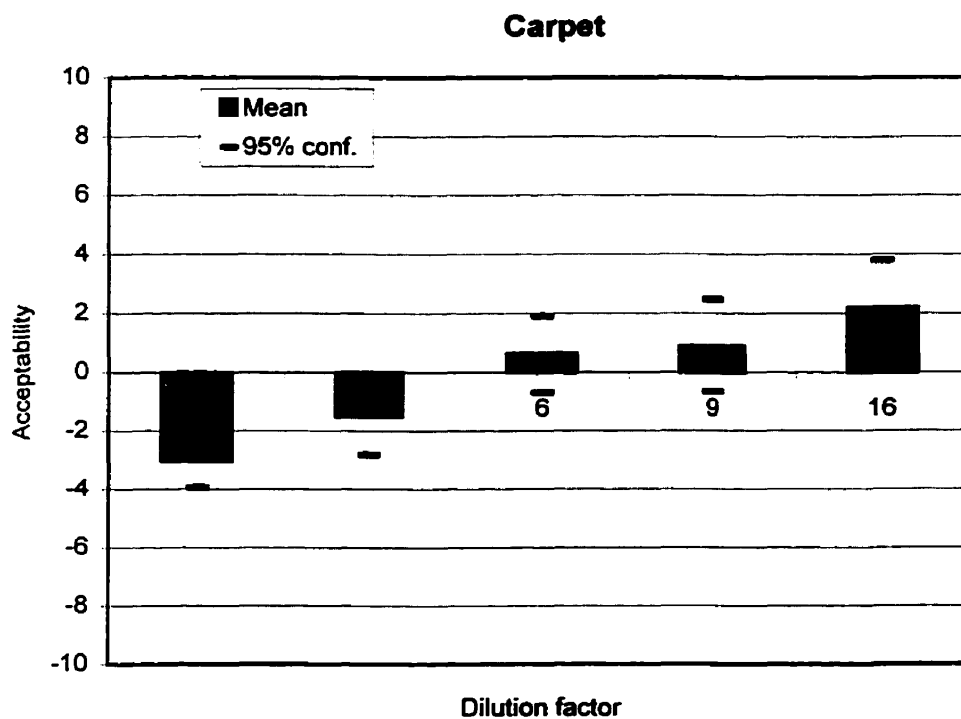
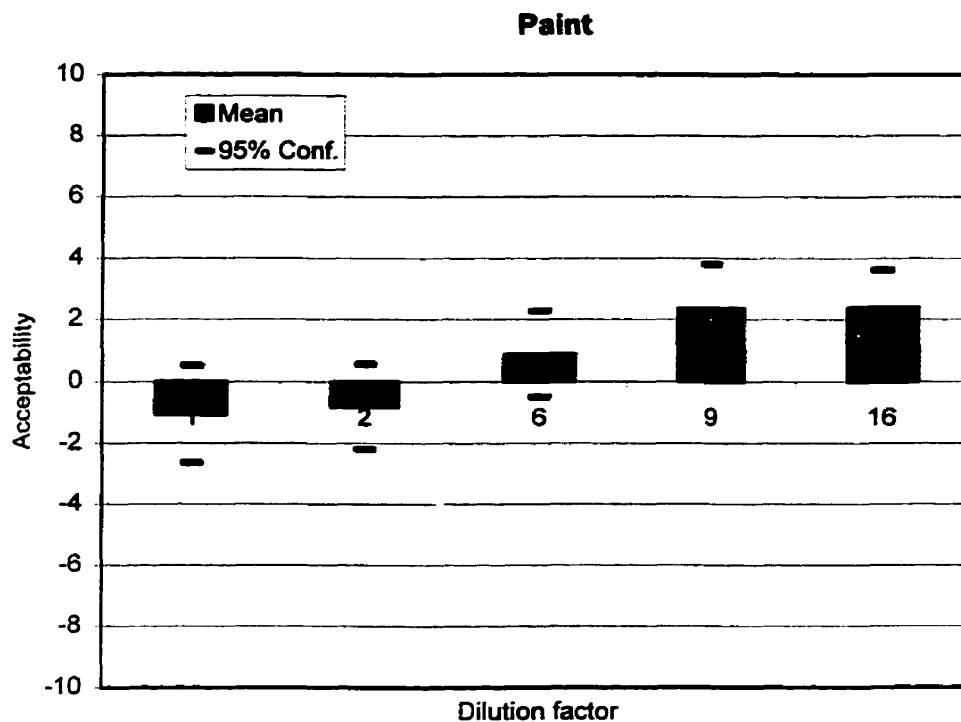

### Vinyl

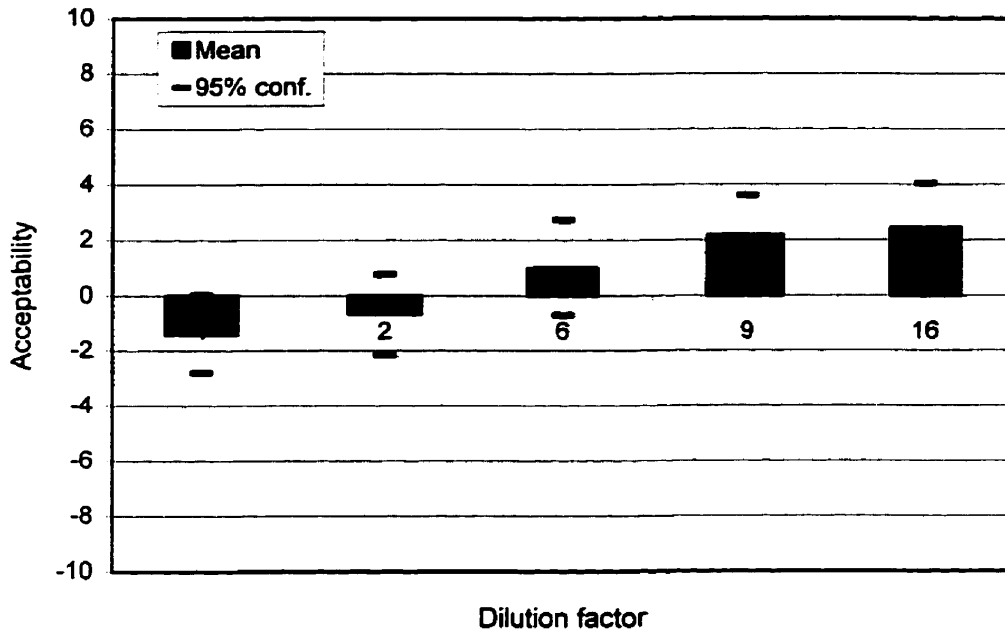

### Supply

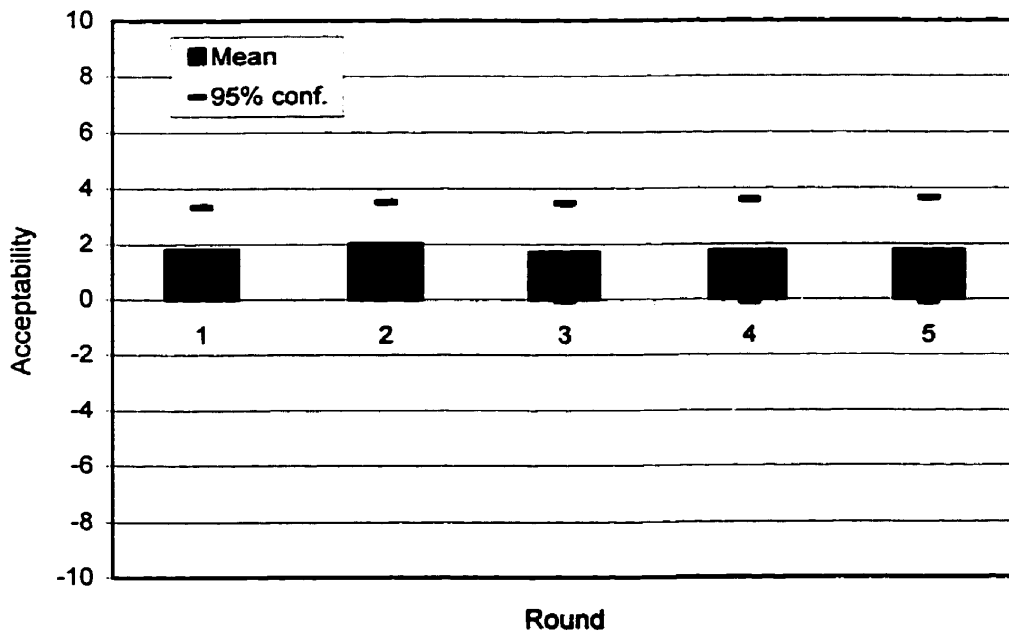

**Figure 4-13**  
**Acceptability as a function of dilution factor**  
**Case of single materials**

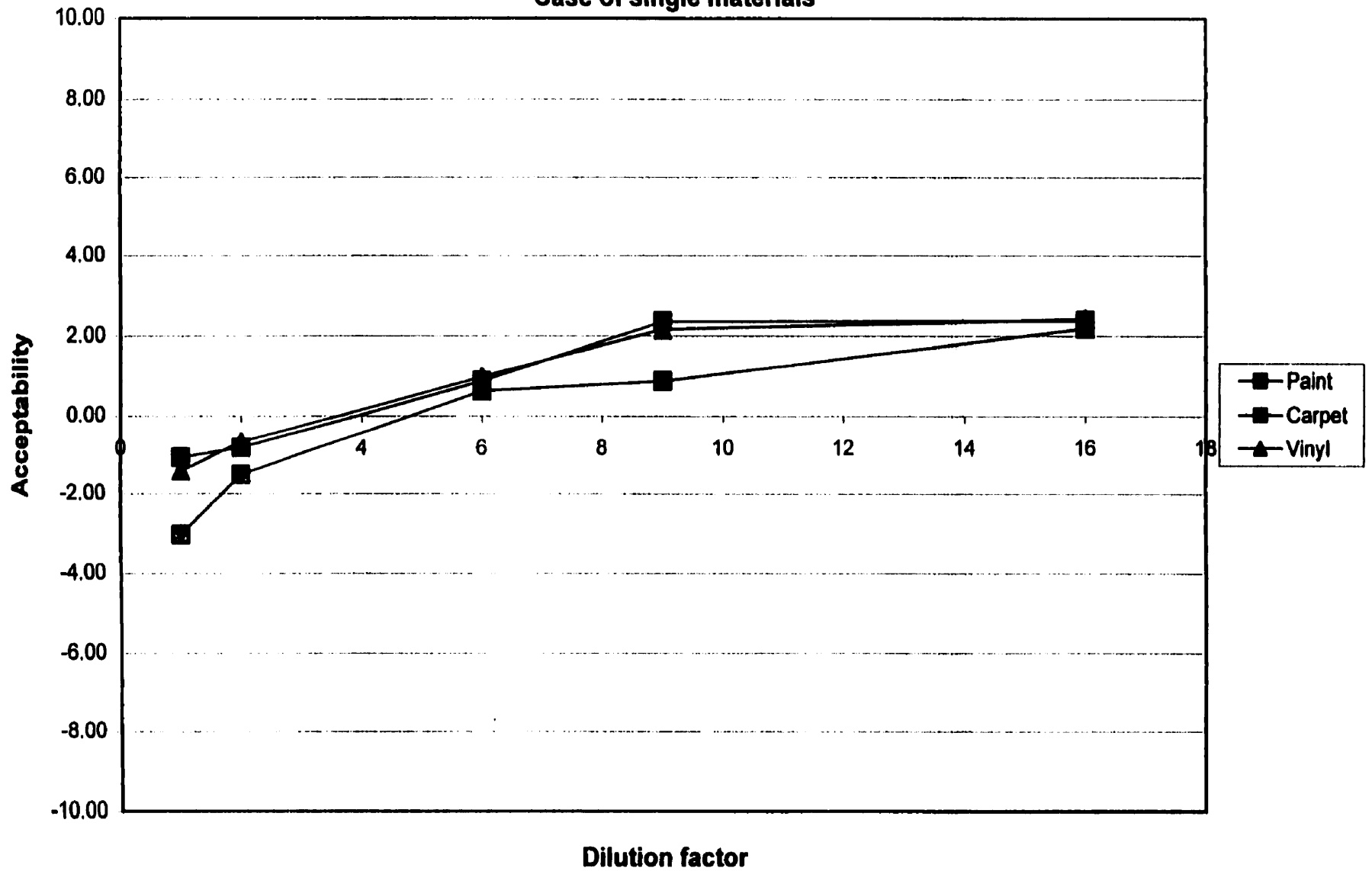

In addition, the size of the samples in the test chambers was almost half of the one used in the first experiment due to the chamber space limitation.

The improvement was pronounced for the three building products. For paint and PVC with 9-fold dilution it was not possible to distinguish between assessments of the chamber with material samples and air supply. The carpet at 16-fold dilution gave almost the same acceptability as the air supply. Figure 4.14 shows the odor intensity as a function of dilution factor for the three building products. These results are in accordance with the ones obtained from the acceptability assessment, which means that the odor was the main cause affecting the acceptability of the perceived air.

The exposure-response relationship between the dilution factor and the mean acceptability vote is shown in Figure 4.15 in a semi-log plot. The points for the various materials provide a linear relationship between acceptability and the dilution factor with a good regression. This relationship is described by the formulas appearing on the same figure. This figure was used to determine the dilution required to achieve certain acceptability.

In the second experiment samples of two building products (vinyl & carpet, paint & carpet or paint & vinyl) were placed in the test chambers six days before a panel of 34 subjects assessed the acceptability and odor intensity of the air. Five rounds of sensory testing were carried out and the dilution factor varied from one round to another and from one test chamber to another randomly. The results are summarized in Table 4.6. Figure 4.16 shows the mean acceptability vote and the 95% confidence interval corresponding to each dilution factor for vinyl & carpet, paint & carpet, for paint & vinyl and for air supply.

**Figure 4-14**  
**Odor intensity as a function of dilution factor**  
**Case of single materials**

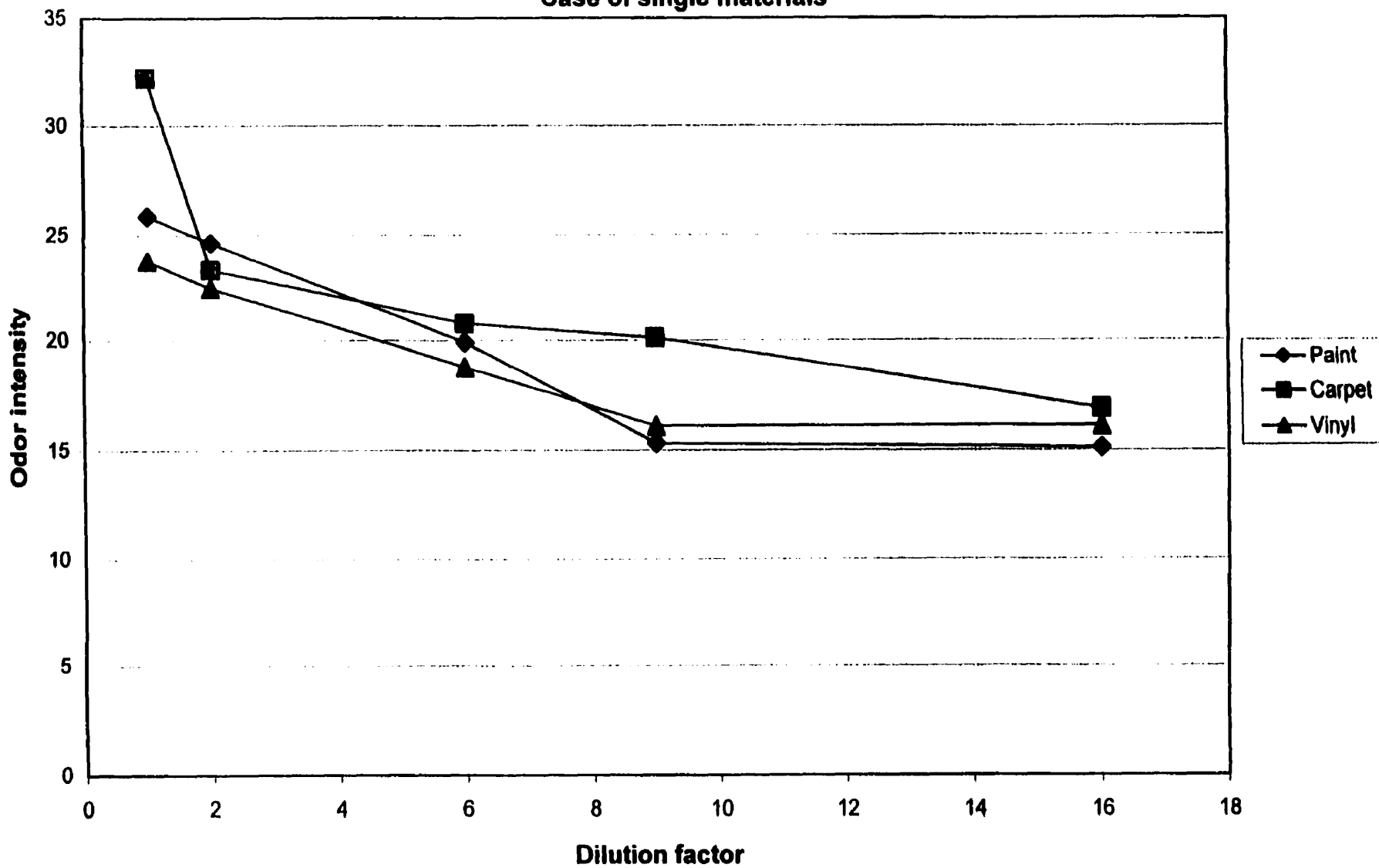



**Figure 4-15**  
**Exposure response relationship**

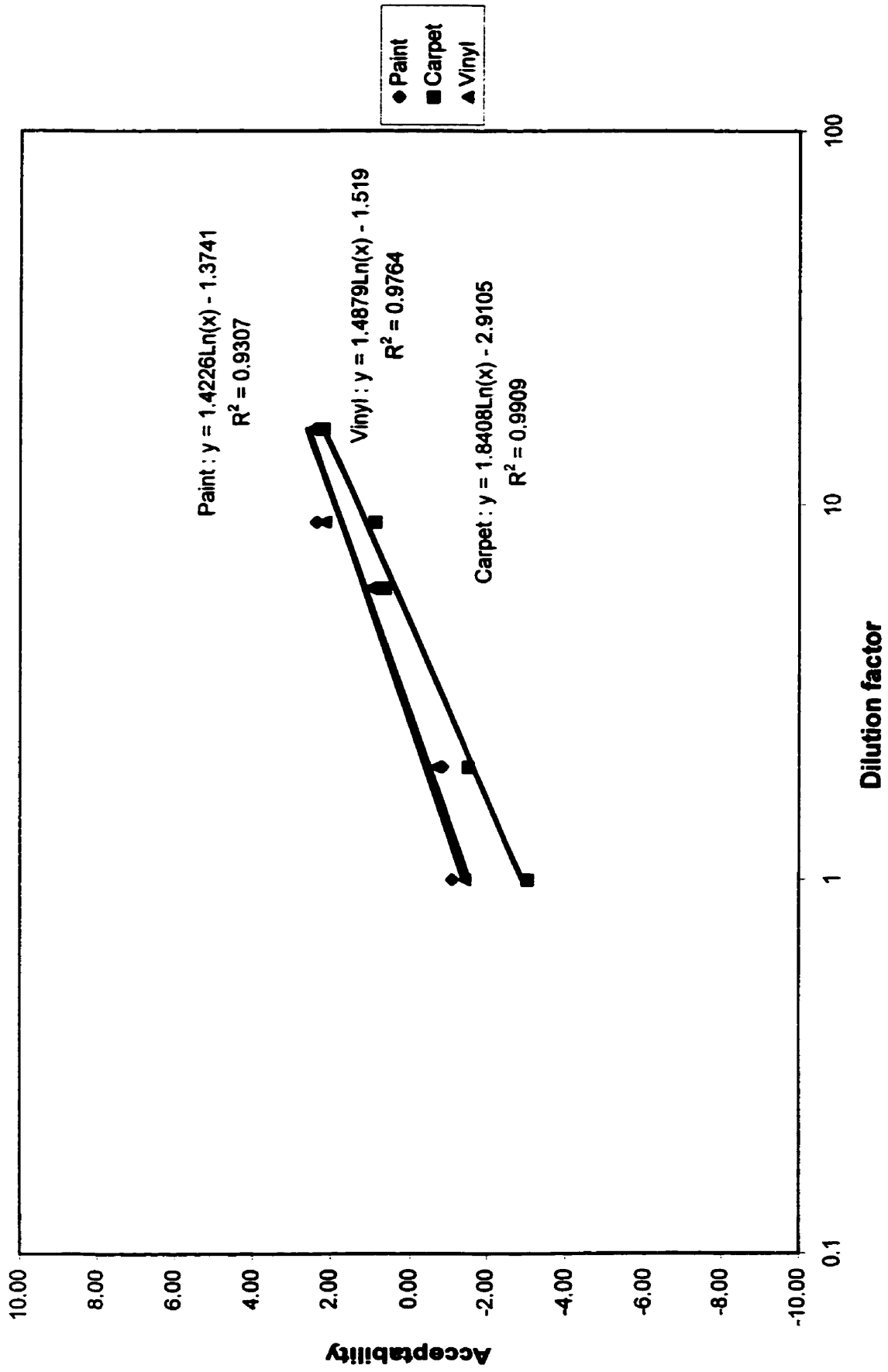

**Table 4-6 Sensory assessment results for dilution experiment when each test chamber contained samples of two different building products**

**Acceptability assessments**

Round	Acceptability											
	Vinyl&Carpet			Paint&Vinyl			Paint&Carpet			Supply		
	Dil.	Mean	Confidence limits	Dil.	Mean	Confidence limits	Dil.	Mean	Confidence limits	Dil.	Mean	Confidence limits
1	1	-2.27	-1.05 – -3.87	1	-0.84	0.54 – -2.22	1	-1.66	-0.30 – -3.02	–	1.67	3.46 – -0.12
2	16	1.83	3.37 – 0.29	2	0.05	1.57 – -1.47	9	0.9	2.56 – -0.76	–	1.31	3.40 – -0.78
3	9	1.58	3.16 – 0.00	6	0.92	2.6 – -1.48	16	1.55	3.23 – 0.13	–	1.65	3.61 – -0.31
4	2	-0.67	1.09 – -2.43	9	1.39	2.95 – -0.17	6	0.58	2.19 – -1.03	–	1.26	2.92 – -0.40
5	6	1.56	2.9 – 0.22	16	1.97	3.55 – 0.39	2	-1.61	0.07 – -3.29	–	1.39	3.17 – -0.39

**Odor intensity assessments**

Round	Odor Intensity											
	Vinyl&Carpet			Paint&Vinyl			Paint&Carpet			Supply		
	Dil.	Mean	Confidence limits	Dil.	Mean	Confidence limits	Dil.	Mean	Confidence limits	Dil.	Mean	Confidence limits
1	1	28	34.94 – 21.06	1	23.88	29.20 – 18.56	1	25.1	30.24 – 19.94	–	18.7	22.56 – 14.92
2	16	16.09	18.78 – 13.40	2	21.16	26.14 – 16.18	9	19.1	22.47 – 15.73	–	20.2	25.37 – 14.99
3	9	19.6	24.12 – 15.08	6	21	25.47 – 16.53	16	18.1	20.88 – 15.24	–	20.2	24.97 – 15.41
4	2	22.43	26.91 – 17.95	9	18.24	21.25 – 15.23	6	19.2	22.24 – 16.06	–	19.9	23.93 – 15.93
5	6	20.49	23.41 – 17.57	16	17.85	21.00 – 14.70	2	24.8	29.03 – 20.53	–	20.4	24.02 – 16.86

Figure 4.16 . Mean acceptability and 95% confidence interval when chamber exhausts were diluted ( case of combined materials)

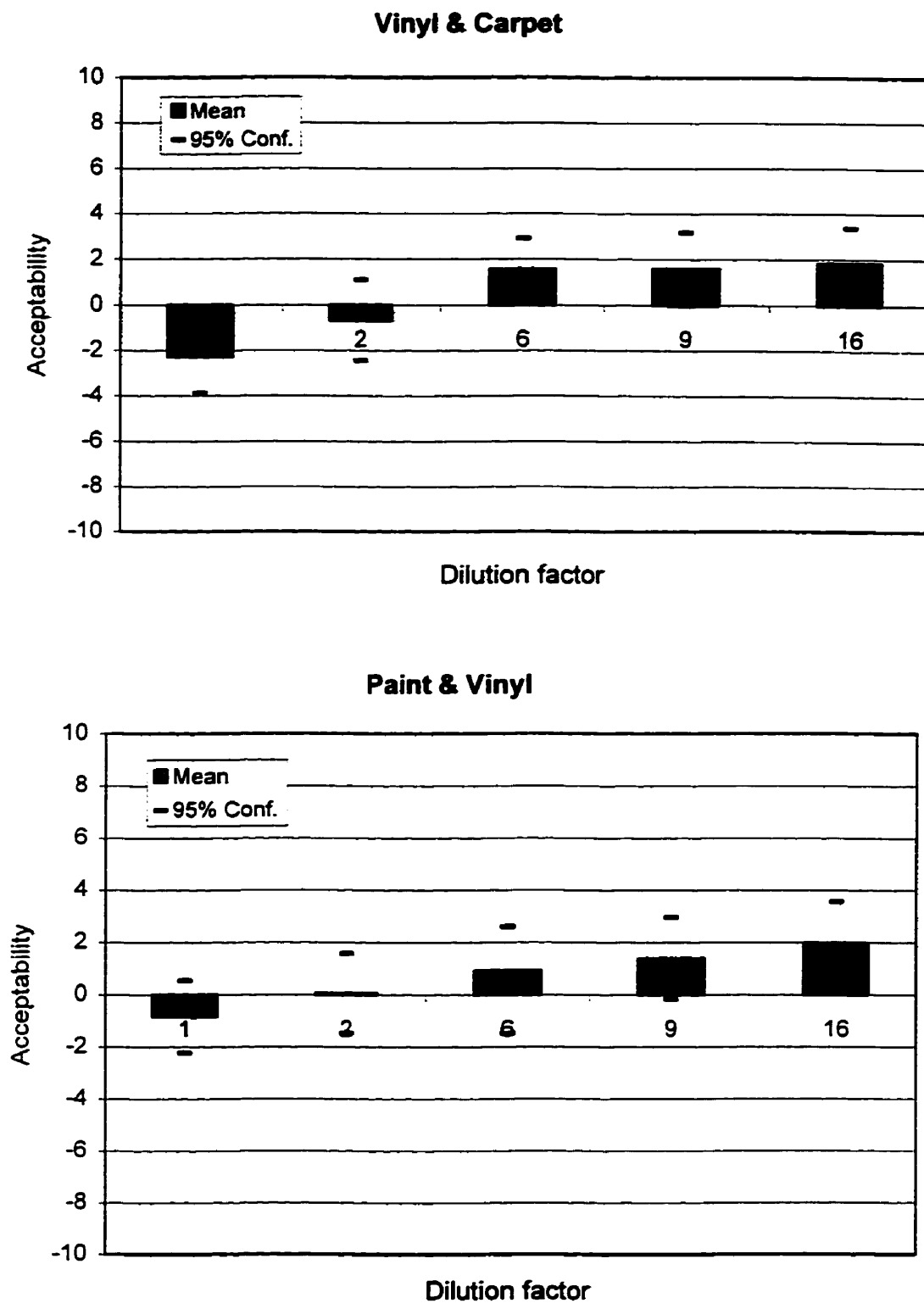

### Paint & carpet

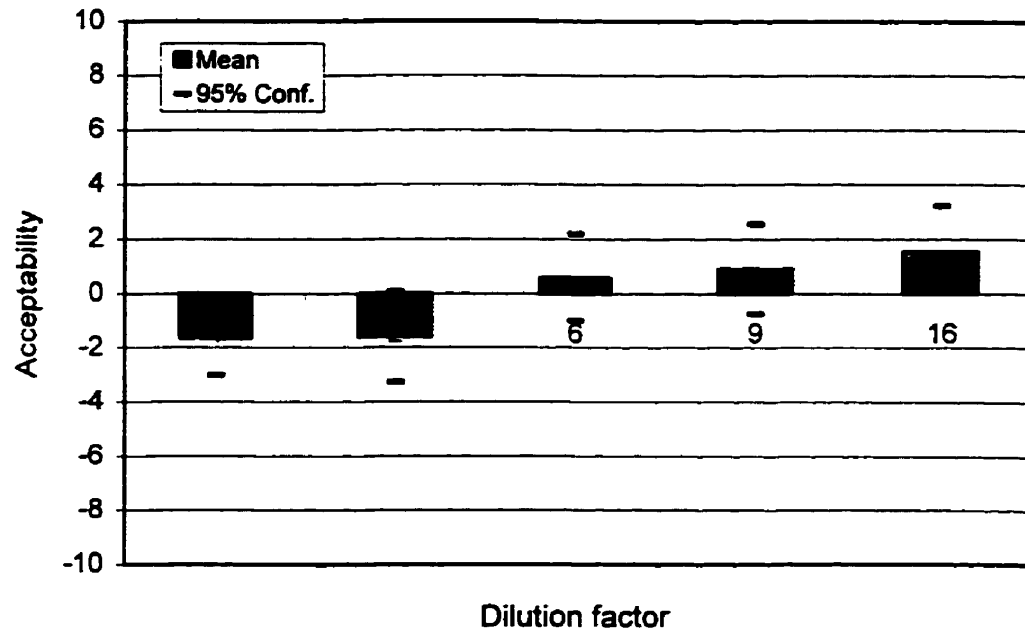

### Supply

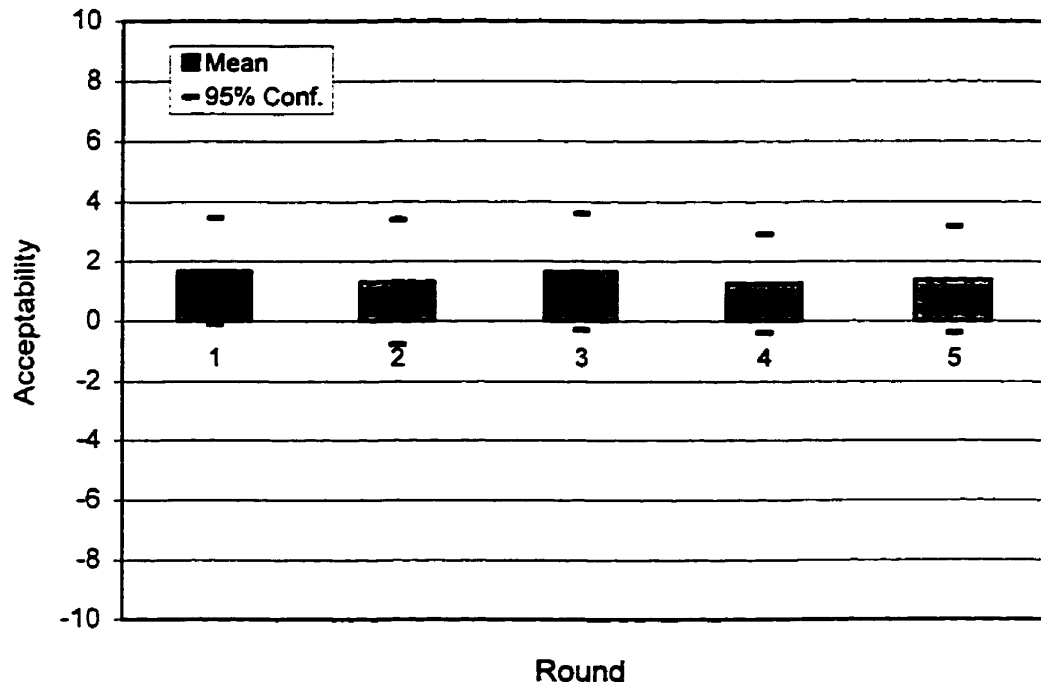

The acceptability as a function of dilution factor for the three combinations of tested materials is shown in figure 4.17. At the highest concentration the mean acceptability vote was -2.3 for carpet & vinyl, -1.66 for paint & carpet and -0.84 for paint & vinyl. The improvement in acceptability is most pronounced for the combination of carpet & vinyl where with 6-fold dilution of the polluted air the acceptability was almost like the one of the supply air. By diluting the chamber air 16 times it was not possible to distinguish the presence of the materials in the test chamber for all the tested combinations. Figure 4.18 shows the relationship between the odor intensity and the dilution factor for the combined samples. Again, the odor intensity decreases when the dilution increases, and this change in odor intensity varies from one combination to another. Figure 4.19 shows the exposure-response relationship in a semi-log plot between the dilution factor and mean acceptability for carpet & paint, paint & vinyl and for paint & carpet. The obtained results for the various combinations of investigated materials provide a linear relationship with a good regression and this figure was used to find the required dilution to achieve certain acceptability.

The ANOVA results for these two experiments show that there is no difference between the single materials and their combinations since:  $[F(1,33) = 0.00001; P = 0.989]$  for the effect of the groups (the only difference between the two groups was the assessed materials: individual or combined materials). The high value of P means that the difference between the groups is not significant.  $[F(2,66) = 0.98; P = 0.379]$  for the effect of materials used in each experiment, and  $[F(2,66) = 4.158; P < 0.019]$  for the interaction of groups and materials. The materials factor and its interaction are useless because the order of the materials and the combinations is arbitrary, and a different order might or

**Figure 4-17**  
**Acceptability as a function of dilution factor**  
**Case of combined materials**

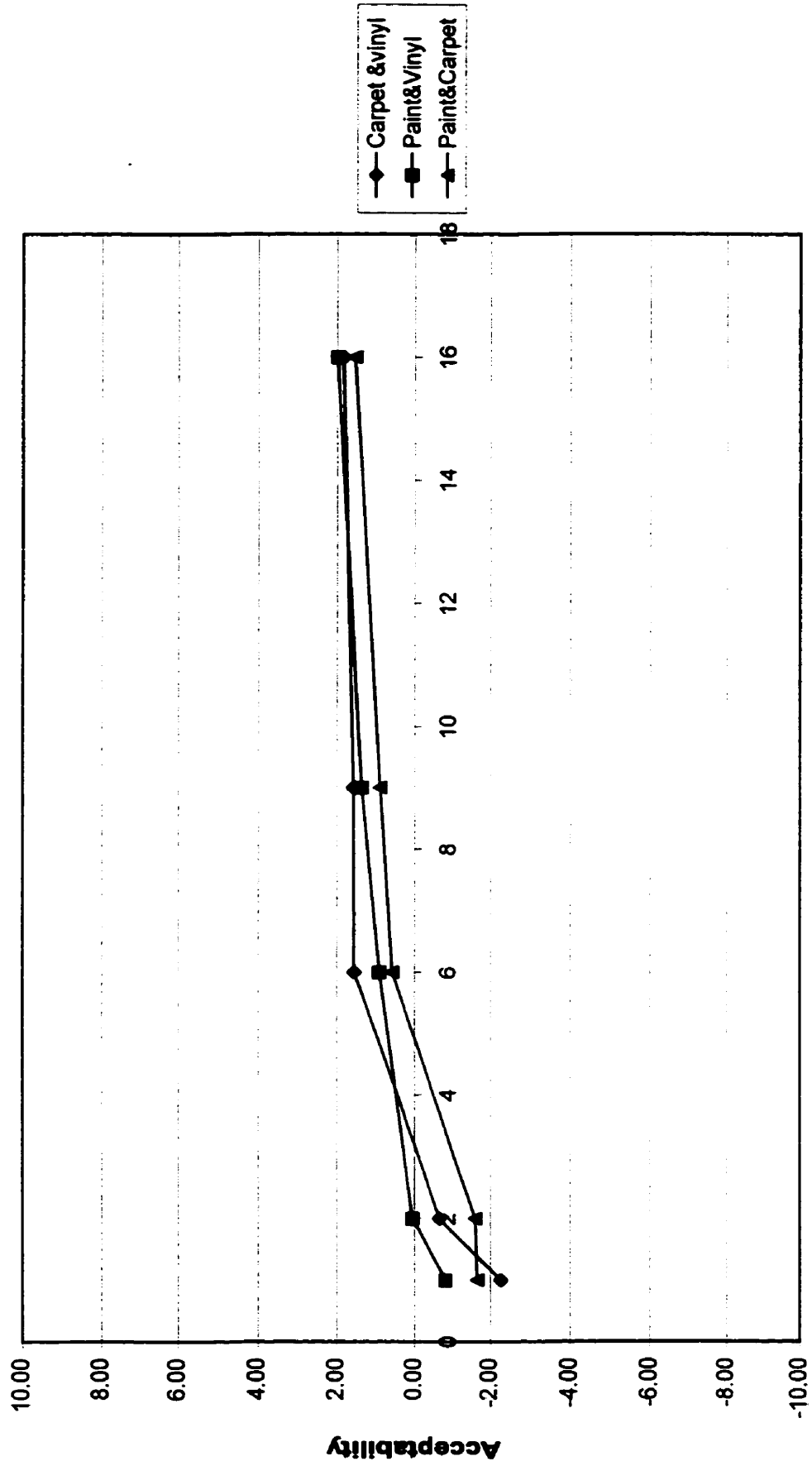

**Dilution factor**

**Figure 4-18**  
**Odor intensity as a function of dilution factor**  
**Case of combined materials**

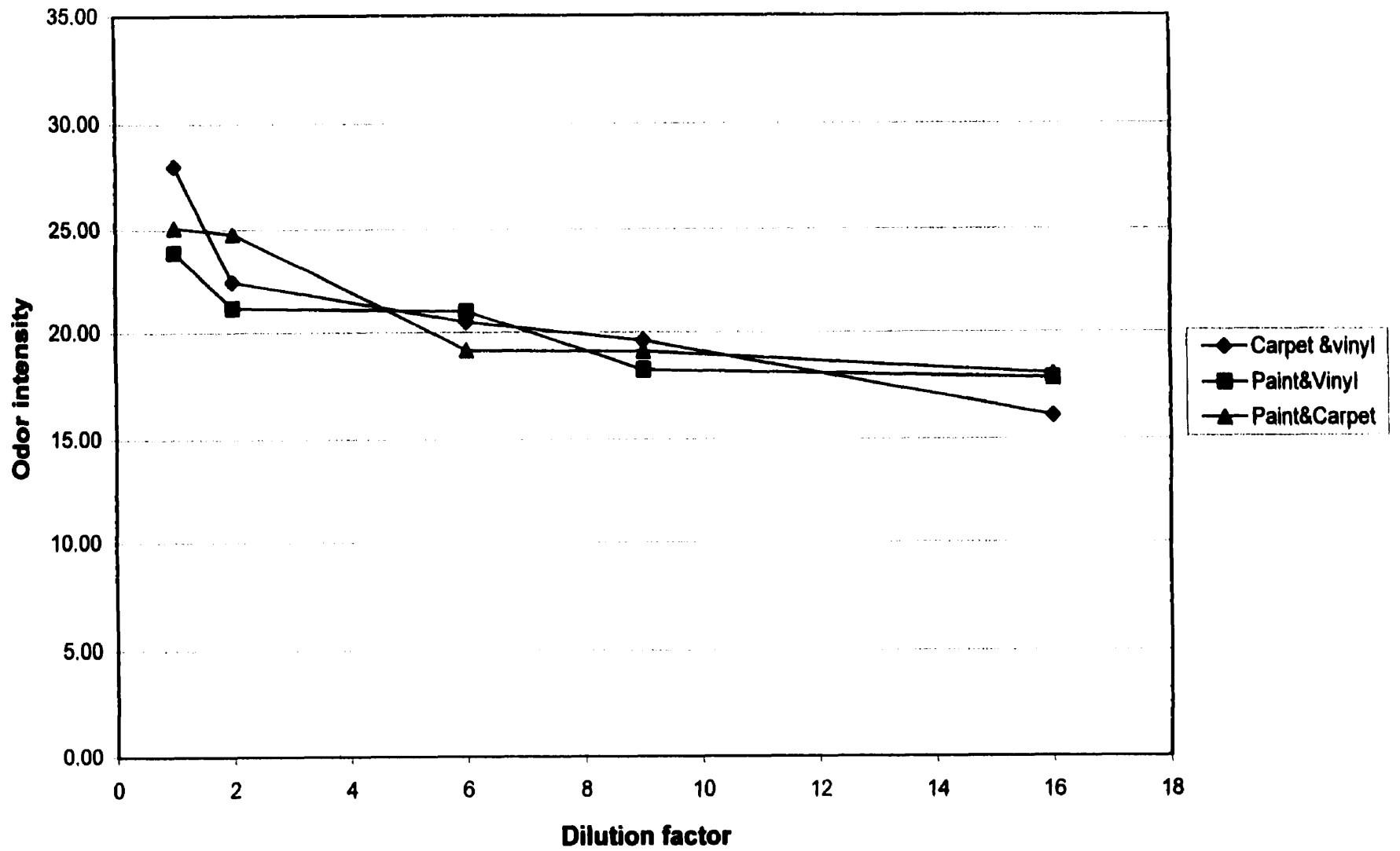

**Figure 4-19**  
**Exposure response relationship**  
**Case of combined materials**

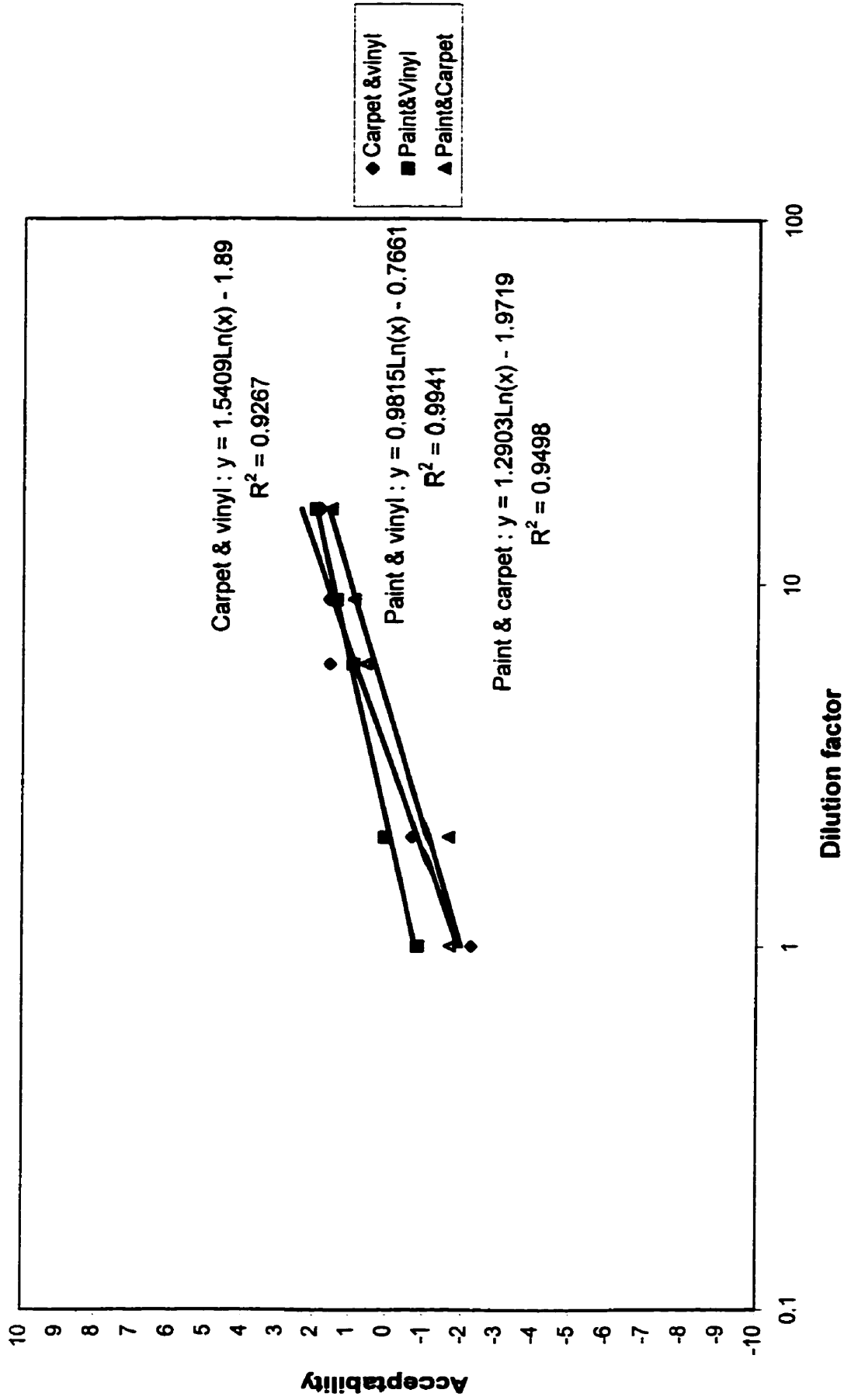



might not produce a significant interaction. For the effect of the dilution: [F (4, 132) = 29.36;  $P < 0.00001$ ] which means that the dilution as a factor is significant for all the materials and their combinations. For the group- dilution interaction: [F (4, 132) = 0.69;  $P = 0.597$ ] this interaction is not significant and means that the dilution had the same effect on single or combined materials. ANOVA results for these two experiments are presented in Appendix 3, and it show that having combinations of materials or single materials does not make a statistically significant difference.

The relationship between acceptability and odor intensity for paint, carpet, PVC, paint & carpet, paint & PVC and carpet & PVC is shown in figure 4.20 and thus for five experiments. For all tested materials (single or mixture) the acceptability improved when the odor intensity decreased. This linear relationship shows that the odor of the tested materials is the main factor affects the quality of the perceived air.

Figure 4.21 shows the standard deviation of the acceptability vote as a function of the mean vote for all the performed experiments. The average standard deviation of the acceptability vote was 4.5. This is similar to the standard deviation of sensory assessment experiments done earlier (Knudsen et al. 1998).



Figure 4.21  
Standard deviation as a function of mean acceptability vote

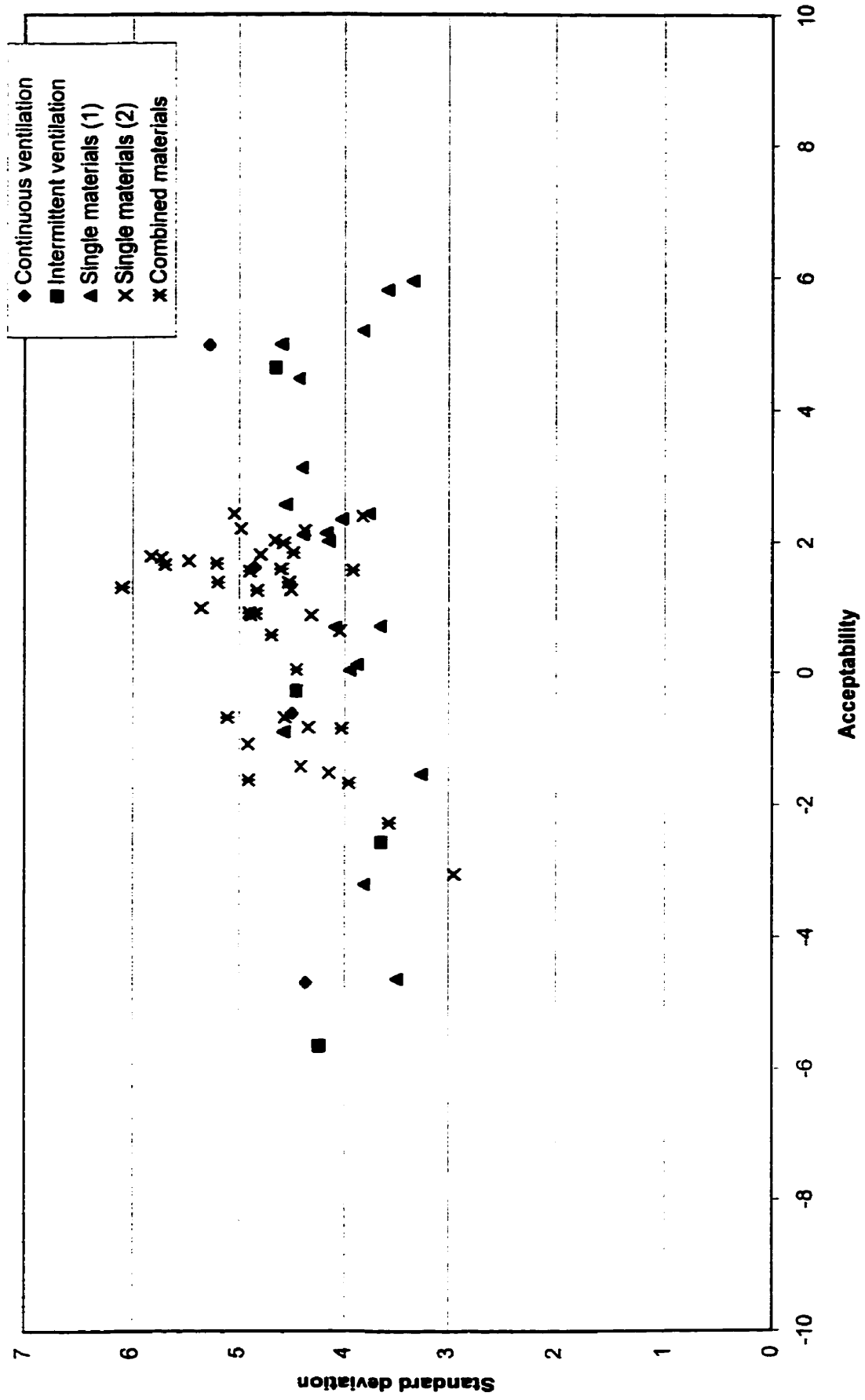

## CHAPTER V

### DISCUSSION

#### 5.1 Effect of ventilation strategies on perceived air quality

The intermittent ventilation strategy is widely used in office buildings where the ventilation systems are turned off during the night in order to save energy. The impact of an intermittent ventilation strategy was investigated along with the impact of continuous ventilation, in both, test chambers and real offices. The obtained results show the negative impact of intermittent ventilation on the perceived air quality (See Figs. 4.5,4.6,4.10 & 4.11). This deterioration could be related to the desorption of pollutants adsorbed on surface materials when the pollutant concentrations in the air are high during the night (ventilation systems are turned off). The desorption occurs when concentrations of pollutants in the air are reduced after the ventilation systems have been turned on. The difference in partial pressure between material and air drives the mass transfer to the air (Knudsen, 1998). The obtained results are in agreement with a previous study on the interaction between sources, sinks and ventilation strategies (Jørgensen et al, 1993) and with another study that dealt with the interaction between different ventilation strategies and the adsorption/desorption of VOCs on material surfaces (Jørgensen et al, 1999). These studies show that the sorption behaviour has to be included when estimating the variation in concentration in a room based on source characteristics and ventilation rates. Figure 4.9 is an exposure response curve for the materials used in the present dilution experiment, and it was used to convert the acceptability obtained from the assessments at the intermittent and continuous ventilation to the required dilution of emissions to

achieve these particular values of acceptability.

The results are shown in table 5.1. More ventilation will be required at intermittent ventilation to maintain acceptability at the level of continuous ventilation. The ratios between these dilutions have an average of 4.2. This means that when intermittent ventilation is applied the materials require on average a 4.2 times higher ventilation rate than for continuous ventilation to compensate for the interruption period of the ventilation systems

**Table 5.1 acceptability assessments at intermittent and continuous ventilation with the required dilutions according to Figure 4.9.**

Materials	Acceptability intermittent ventilation	Acceptability continuous ventilation	Required dil. to match intermittent ventilation	Required dil. to match continuous ventilation	Ratio between dilutions
Carpet	-2.55	-0.61	0.45	1.46	3.3
Paint	-0.27	1.61	0.66	5.26	7.9
PVC	-5.65	-4.69	0.74	1.08	1.5

The main objective of the laboratory tests is to be able to predict the perceived air quality in a real room. For this reason, a model room, with specified dimensions, was used to determine the area specific ventilation rate required in the test chamber. This was done to reflect realistic pollution concentrations. However, for the two ventilation strategies investigated, it was observed that the acceptability for single products in the test chamber was consistently and significantly lower than that obtained from the sensory assessments in the three offices. The reason is that the offices were old and the contribution of odor from construction materials was limited. Newer materials are in the steep part of aging curve, which mean the effect of time on reducing the pollution emission from the

materials is more pronounced when they are new. Another reason is the high air exchange rate in the investigated offices when the ventilation system were stopped (ACH=1) while it was almost zero in the test chambers during the no ventilation period. The observed differences between laboratory and real office data cannot be explained by the above factors alone. Other factors that could have an impact on these differences include: status of adaptation of the sensory panel members, the context in which the assessments are performed, psychological factors related to the panel members, familiarity and experience with the odours, and the impact of combining materials with respect to perception and secondary processes like sorption and oxidation (Knudsen, 1998)

## **5.2 The additive effect of building products on perceived air quality**

The dilution experiment allowed the determination of exposure-response relationships for each tested building product and for different combinations of two building products. Such relationships make it possible to quantify the impact of emissions from building products on the perceived air quality at different concentrations and to assess the impact of dilution of polluted air. The concentration of polluted air for the different building products was produced by having a realistic range of the area specific ventilation rate in the test chambers (assuming 50% of the model room walls are painted and just half of its floor is covered by carpet or/and PVC). The reason for this was to test each material at the highest concentration that would occur in the assumed model room with that material alone and then with a combination of two materials. The lower concentrations were achieved by similar dilution factors for the different building

products and their combinations. The effect of dilution of the polluted air on the perceived air quality varied between the building products as shown in Figure 4.13, and between each combination of two materials as shown in Figure 4.17. The exposure-response relationships for each building product are shown in Figure 4.15. A difference in slope is seen between carpet and the other two tested materials, paint and vinyl, while almost no difference in slope exists between paint and vinyl. The slope of the exposure-response relationship determines the effect of changing the ventilation rate in a space containing the actual material: a shallow slope means more dilution is needed to achieve certain acceptability. The results are in agreement with previous studies of sensory characterization and the exposure-response relationships for emissions from building products (Knudsen et al., 1997 and Knudsen et al., 1998). Figure 4.19 shows the exposure-response relationships for combinations of different building products, and a difference in the slopes for the different building products is seen. Table 5.2 shows the slope of the exposure-response curves along with the required dilution of emissions from individual materials and their combinations to achieve acceptability equal to the one for an empty chamber assuming that this acceptability equals 2.

**Table 5.2. Acceptability assessments for individual and combined materials with the required dilution needed to reach the acceptability of an empty chamber.**

Materials	Paint	Carpet	PVC	PVC& Carpet	Paint & PVC	Paint & Carpet
Acceptability without dilution	-1.07	-3	-1.4	-2.27	-0.84	-1.66
Slope of exposure-response curve	1.42	1.84	1.48	1.54	0.98	1.29
Required dil. to match supply air acceptability	10.7	14.4	10.6	12.4	16.7	21.7

The results show that, in general, the perceived air quality improved when two materials were combined together, and the degree of improvement varied from one combination to another. However, to achieve the same acceptability, more ventilation will be required for a combination of two materials than for one material. E.g. an office with a new carpet, similar to the one used in this test, will need approximately 14 times more ventilation to achieve an acceptability like the one of the supply air in the laboratory (air without strong odor). If the same office were painted too, the ventilation rate should be increased 22 times to reach the same acceptability of the supply air. This increase in ventilation rate is not possible in most of the actual ventilation systems. In order to design an effective ventilation system, the ventilation rates should be based on emissions from the materials in the buildings.



## **CHAPTER VI**

### **CONCLUSIONS**

#### **6.1 Effect of ventilation strategies on perceived air quality**

Stopping the ventilation at night lowers the air quality in the daytime when the ventilation is turned on again. This deterioration could be explained by sorption phenomena where pollutants adsorbed at night are reemitted during the day and by the slower removal of pollutants at reduced average ventilation rates when an intermittent ventilation strategy is applied. Compared to continuous ventilation, intermittent ventilation increases the emission rates from building products both in test chambers and in real offices. The results show a larger negative impact of intermittent ventilation on the perceived air quality in small test chambers than in real offices. Based on the acceptability of the air quality, the effect of stopping the ventilation half the time may increase the daytime ventilation requirement 4 times or more to reach the same level of air quality.

#### **6.2 The additive effect of building products on perceived air quality**

Laboratory experiments, exposing humans to varying concentrations of pollutants (obtained by dilution), were conducted to establish an exposure-response relationship. This relationship was used to assess the impact of emissions from varying concentrations of building products (paint, carpet, PVC and their combinations) on the perceived air quality. The resulting information allowed for the determination of the most appropriate ventilation based on the criteria of acceptable air quality. The effect of dilution of the

polluted air on the perceived air quality varied between the building products. The experimental results show that, for combined materials, the assessed air quality is better than for a single material. However, combined materials require higher ventilation than single materials to achieve specified acceptable levels, and this ventilation varies from one combination to another.

### **6.3 Acceptability vs. odor intensity**

For all the conducted experiments, a linear relationship between acceptability and odor intensity was found. It shows that the odors emitted from the building products affect the acceptability and are the cause of poor air quality. This relationship allows the determination of the odor level associated with an acceptable air quality.

### **6.4 Future Work**

The results of this work showed that the slopes of the exposure-response curves, which determine the effect of changing the ventilation rate, decrease when the materials are combined: the slopes of exposure-response curves for single materials are steeper than the slope for combined materials. That means the ventilation rate needed to reach certain acceptability level will be higher for a combined material than the ventilation rate needed for the individual materials. Now the questions are:

1. Is the slope of the exposure-response a function of temperature or humidity?
2. Does the ventilation rate depend on whether the material is wet or dry?
3. Does this rate depend on whether it is a single or a combination of three or more materials?

4. How can one obtain the upper limit of ventilation as solution to improve the indoor air quality?

## REFERENCES

1. ASHRAE (1989) " Ventilation for Acceptable Indoor Air Quality" , Atlanta , GA , American Society of Heating , Refrigerating and Air Conditioning Engineers, ASHRAE standard 62-1989.
2. Bluysen, P.M., Cornelissen, H.J.M., Hoogeveen, A.W., Wouda, P., van der Wal, J.F.(1996) " The effect of temperature on the chemical and sensory emission of indoor materials" Nagoya: Proceedings of the 7<sup>th</sup> International Conference on Indoor Air Quality and Climate Vol. 3, 619-624.
3. Bluysen, P.M., Cornelissen, H.J.M. (1995) " Equipment used to train a panel in perceived air quality: Recommendations ". Milano : Proceedings of the international conference on healthy buildings in mild climate , Vol. 2, 929-934.
4. Bluysen, P.M., Fernandes, E.O. (1994)" The European IAQ-Audit project: General Methodology and Preliminary Results" Budapest: Proceedings of the 3<sup>rd</sup> International conference on Healthy Buildings, Vol. 3, 86-91.
5. Bluysen, P..M., Walpot, J.I. (1993) " Sensory evaluation of perceived air quality" , Helsinki Proceedings of the 6<sup>th</sup> International Conference on Indoor Air Quality and Climate. Vol. 1 , 65-70.
6. Bluysen, P..M.(1991)" Air quality evaluated with the human nose". Air infiltration review Vol.12, 4 , 5-9.
7. Bluysen, P.M., (1990) " Air quality evaluation by a trained panel" Ph.D. thesis, Copenhagen, Laboratory of Heating and Air Conditioning, Technical University of Denmark.
8. Berglund, B., Lindvall, T. (1990) " Sensory criteria for healthy buildings " Toronto: Proceedings of the 5<sup>th</sup> International Conference on Indoor Air Quality and Climate Vol. 5, 65-79.
9. Berglund, L., Cain, W.S. (1989) " Perceived Air quality and thermal environment", in the Human Health equation , ASHRAE, 93-99
10. Berglund, B., Berglund, U., Lindvall, T. and Nicander-Bredberg, H. (1982) "Olfactory and chemical characterisation of indoor air. Towards a psychophysical model for air quality. Environment International, Vol.8, 327-332
11. Berglung, B., Berglund, U., Ekman, G., Engen, T. (1971)" Individual psychophysical functions for 28 odorants " Perception and Psychophysics, Vol. 9 (3B), 379-384

12. Balez,S. (1998) "Un outil d'analyse interdisciplinaire de l'environnement olfactif: L'effet odorant" Lyon: Proceedings of the 2<sup>nd</sup> european conference on energy performance and indoor climate in buildings and 3<sup>rd</sup> international conference on indoor air quality ventilation and energy conservation in buildings, Vol.1, 297-301.
13. Cain, W.S., Cometto-Muniz, E. (1993) "Irritation and Odor : Symptoms of Indoor Air Pollution " Helsinki : Proceedings of the 6<sup>th</sup> International Conference on Indoor Air Quality and Climate. Vol.1 , 21-31.
14. Cain,W.S. (1985) " Perception of odor intensity and the time course of olfactory adaptation" ASHRAE Trans. Vol.80, 53-75.
15. Cain, W., Leadeper, B.P., Isseroff, R., Berglund, L.G., Huey. R.J., Lipsitt, E.D., Perlman,D. (1983) " Ventilation requirements in buildings- I. control of occupancy odor and tobacco smoke odor " Atmospheric Environment, Vol. 17, No. 6, 1183-1197
16. Cain, W.S. (1969)"Odor intensity: Differences in the exponent of the psychophysical function " Perception and Psychophysics , Vol.6 (6A) , 349-354.
17. Clausen, G., Fernandes , E.de O. (1997) "European data base on indoor air pollution sources in buildings " Final report , Vol.1
18. Elkhuizen, P.A., Bluysen, P.M., Groes, L., Aizlewood,C. ( 1995) " A new approach to determine the performance of a trained sensory panel", Milano: Proceedings of international conference on healthy buildings in mild climate, Vol. 3,1365-1370
19. European Collaborative Action," Sensory evaluation of indoor air quality" (ECA-IAQ) 1999, Submitted.
20. European Concerted Action, " Guidelines for Ventilation Requirements in Buildings" report No 11, CEC, 1992.
21. Engen, T. (1986) " Perception of odor and irritation" Environment International, Vol.12, 177-187.
22. Engen, T. (1982) " The perception of odors" New York, N.Y.: Academic Press.
23. Fang, L., Clausen, G., Fanger, P.O. (1996) " The impact of temperature and humidity on perception and emission of indoor air pollutants" Nagoya: Proceedings of the 7<sup>th</sup> International Conference on Indoor Air Quality and Climate Vol.4, 349-354.
24. Fanger, P.O. (1989) " The new comfort equation for indoor air quality " ASHRAE journal, October 1989, 33-38.

25. Fanger, P.O, Lauridsen, J., Bluysen, P., Clausen, G. (1988) " Air pollution sources in offices and assembly halls quantified by the olf unit " Energy and Buildings, 12, 7-19.
26. Fanger, P.O. (1988)" Introduction of the olf and decipol units to quantify air pollution perceived by humans indoors and outdoors" Energy and Buildings, 12,1-6
27. Gunnarsen, L., Nielsen, P.A., and Wolkoff, P. (1994) " Design and Characterization of the CLIMPAQ Chamber for Laboratory Investigations of Materials Pollution and Air Quality"Indoor Air, 4, 56-62.
28. Gunnarsen, L.(1994) "Sensory measurements using trained and untrained panels" Budapest: Proceedings of the 3<sup>rd</sup> International conference on Healthy Buildings, Vol. 2, 533-538
29. Gunnarsen,L.,Nielsen,P.A.,Nielsen,J.B.,Wolkoff,P.,Knudsen,H.,Thogersen,K (1993) "The Influence of specific ventilation rate on the emissions from construction products", Helsinki: Proceedings of the 6<sup>th</sup> International Conference on Indoor Air Quality and Climate, Vol.1, 501-506.
30. Gunnarsen, L., Fanger, P.O. (1992) "Adaptation to indoor air pollution" Environment International, Vol. 18, 43-54.
31. Gunnarsen, L. (1990) "Adaptation and ventilation requirements" Toronto: Proceedings of the 5<sup>th</sup> international Conference on Indoor Air Quality and Climate, Vol.1, 599-604.
32. Haghghat, F., De Bellis, L. (1998) " Material Emission Rates: Literature Review, and the Impact of Indoor Air, Temperature and Relative humidity " Building and Environment, Vol. 33, No 5, 261-277.
33. Hudnell, H.K., Otto, D.A., House, D.E., Molhave, L. (1990) " odor and irritation effects of a volatile organic compound mixture " Toronto: Proceedings of the 5<sup>th</sup> International Conference on Indoor Air Quality and Climate Vol. 1, 263-268
34. Iwashita, G., Kimura, K. (1994) " Experimental study on surface emission rate of perceived air pollutants: influence of air velocity " Proceedings of the 3<sup>rd</sup> International conference on Healthy Buildings, Vol. 1, 469-474.
35. Iwashita, G., Kimura, K., Doi, S., Sato,T. (1990) " Indoor air quality assessment based on olfactory sensation" Toronto: Proceedings of the 5<sup>th</sup> International Conference on Indoor Air Quality and Climate Vol. 1, 355-360
36. Knudsen, H.N., Nielsen, P.A. (1997) " Method for sensory characterization for building materials" submitted to Healthy Buildings / IAQ' 97, Washington DC.

37. Knudsen, H.N., Clausen G. and Fanger P.O. (1993) " Prediction of perceived air quality in a space based on small-scale experiments", Helsinki: Proceedings of the 5<sup>th</sup> International Conference on Indoor Air Quality and Climate, Vol. 2, 585-590.
38. Knudsen, H.N., Clausen, G., Fanger, P.O. (1997) " Sensory characterization of emissions from materials " Indoor Air, Vol. 7, 107-115.
39. Kjaer, U.D., Nielsen, P.A., Marcussen, L., Wolkoff, P. (1996) " Characterization of emission from building products: Selection criteria, Storage, and Handling of Indoor materials for experiments" Nagoya: Proceedings of the 7<sup>th</sup> International Conference on Indoor Air Quality and Climate Vol. , 573-578.
40. Karpe, F., Kirchner, S., Rouxel, P. (1995) " Sensory evaluation of wall and floor covering using an odor intensity method", Milano: Proceedings of international conference on healthy buildings in mild climate, Vol. 2, 935-940
41. Menzies, R.I., Tramblyn, R.M., Tramblyn b., Farant, J.P., Hanley, J., Spitzer, W.O. (1990) " Sick Building Syndrome: The effect of changes in ventilation rates on symptom prevalence " Toronto: Proceedings of the 5<sup>th</sup> International Conference on Indoor Air Quality and Climate Vol. 1, 519-524.
42. Moschandreas, J.D. (1992) "Odors in indoor non-industrial environments", Montreal: Proceeding of 1<sup>st</sup> Indoor air quality ventilation and energy consumption in buildings, 255-265
43. Oseland, N.A., Aizlewood, C.E., Raw, G.J. (1994) " The new units of perceived air quality: where are we now? " Budapest: Proceedings of the 3<sup>rd</sup> International conference on Healthy Buildings. Vol. 1, 513-518.
44. Parine, N., Oreszyn, T. (1994) " The perception of indoor air quality and odor" Budapest: Proceedings of the 3<sup>rd</sup> International conference on Healthy Buildings, Vol. 1 , 475-480.
45. Pejtersen, J., Mayer, E. (1993) "Performance of a panel trained to assess perceived air quality" Helsinki : Proceedings of the 6<sup>th</sup> International Conference on Indoor Air Quality and Climate. Vol.1, 95-100.
46. Pejtersen, J., Øie, L., Skar, S., Clausen, G., Fanger, P.O. (1990) " A simple method to determine the olf load in a building" Toronto: Proceedings of the 5<sup>th</sup> International Conference on Indoor Air Quality and Climate Vol. 1, 537-542.
47. Reinikainen, L.M. (1993) "The effect of humidification on perceived indoor air quality assessed by an untrained odor panel " Helsinki : Proceedings of the 6<sup>th</sup> International Conference on Indoor Air Quality and Climate. Vol.1 , 101-105.
48. Saarela, K., Clausen, G., Pejtersen, J., Tirkkonen , T., Tähtinen, M., Dickson, D. (1996) "European Data Base on Indoor Air Pollution Sources in Buildings,

principles of the protocol for testing of building materials ”\_Nagoya: Proceedings of the 7<sup>th</sup> International Conference on Indoor Air Quality and Climate Vol. 3, 83-88.

49. Schiffman,H.R (1996)“Sensation and Perception”.4thedition,John Wiley&Sons,Inc.
50. Tucker, W.G. (1993) “ Status of ASHRAE standards 62-ventilation for acceptable indoor air quality” Helsinki : Proceedings of the 5<sup>th</sup> International Conference on Indoor Air Quality and Climate, Vol. 3, 525-530
51. Villberg,K.,Tirkkonen,T., Saarela,K. (1998)“ Comparison of chemical and sensory results of material emission measurements in the Finnish classification of finishing materials” Lyon: Proceedings of the 2<sup>nd</sup> European conference on energy performance and indoor climate in buildings and 3<sup>rd</sup> international conference on indoor air quality ventilation and energy conservation in buildings,Vol.1, 303-308.
52. World Health Organization (WHO),“Air Quality Guidelines for Europe”, WHO,1987
53. World Health Organization, “ Indoor Air Quality: Organic pollutants”, Copenhagen, EURO Reports and Studies No 111, 1989.
54. Wolkoff , P. (1998) “ Impact of air velocity, temperature , humidity, and air on long-term VOC emissions from building products” Atmospheric Environment, Vol. 32, No 14/15, 2659-2668
55. Wolkoff, P., Nielsen, P. (1994) “ Indoor climate labelling of building products , chemical emission testing , modeling, and indoor relevant odor thresholds” Budapest Proceedings of the 3<sup>rd</sup> International conference on Healthy Buildings, Vol. 1, 231-236.
56. Wolkoff, P. (1994) “ The relevance of long –term emission testing of VOCs from building products ” Budapest: Proceedings of the 3<sup>rd</sup> International conference on Healthy Buildings. Vol. 3, 207-214.
57. Wolkoff, P., Clausen, P.A., Nielsen,P.A., Mølhave (1991)“ The Danish twin apartment study; part 1: Formaldehyde and long-term VOC measurements. Indoor Air, Vol. 4, 478-490
58. Yaglou ,C.P., Riley,E.C., Coggins, D.I. (1936)“ Ventilation requirements”. ASHVE transactions. 42, 133-162.
59. Zellweger,C., Gehrig, R., Hill, M., Hoffer,P. (1995) “ VOC emissions from building materials : Comparison of chamber emission data with concentrations in real rooms” Proceedings of the International Conference on Healthy Buildings in mild climate, Vol.2, 845-850



# **APPENDIX I**



### **Calibration of the chambers:**

The three test chambers have been calibrated before each experiment in order to assure the same ACH and airflow rate in all the chambers, for sensory testing an airflow rate of 0.9 L/s is recommended (Bluyssen, 1990; Clausen et al., 1995; Knudsen, 1994). For calibration CO<sub>2</sub> gas was used as a tracer gas. Before the injection of a specific quantity of CO<sub>2</sub> in each chamber, the background concentration of this gas in that chamber should be measured, and after the injection a reading of the CO<sub>2</sub> concentration inside the chamber was taken with CO<sub>2</sub> analyzer (Progeco tech.PL-CO<sub>2</sub>) every 30 sec interval till the concentration in the chamber equal the background concentration. The ACH could be found from the plot of logarithm the concentration versus the time and is equal to the slope of the resulted line.

The decay curve is presented with the following equation:  $C = C_0 e^{-NT}$

Where C: CO<sub>2</sub> concentration in the chamber, C<sub>0</sub>: initial concentration or background concentration of CO<sub>2</sub>, N : Air exchange rate (min<sup>-1</sup>) , T : time (min)

The ACH inside the chamber was adjusted by control of the airflow through the recirculation channel of the test chamber by a damper.

For the dilution experiment, and in order to adjust the performance of the dilution system a CO<sub>2</sub> gas was dozed at a constant rate into the test chamber. The relative dilution of the exhaust air from the test chamber was determined by measuring the concentration of CO<sub>2</sub> in the diffuser and in the chamber using (Horiba PIR 2000 ), see figure 1. The size of the holes in the orifice plates were determined using trial and error and they were approved only when the change of them did not affect neither the CO<sub>2</sub> concentration in the exhaust air from the test chamber nor the air flow rate out of the diffuser. The airflow rate through

the diffuser was kept constant at 0.9L/s, and to assure that, the air velocity at the end of the diffuser was measured continuously with a hot wire anemometer (TSI air velocity transducer model 8470-20M-V) during all the dilution steps and it was kept around 0.25m/s which corresponds to 0.9L/s air flow rate.

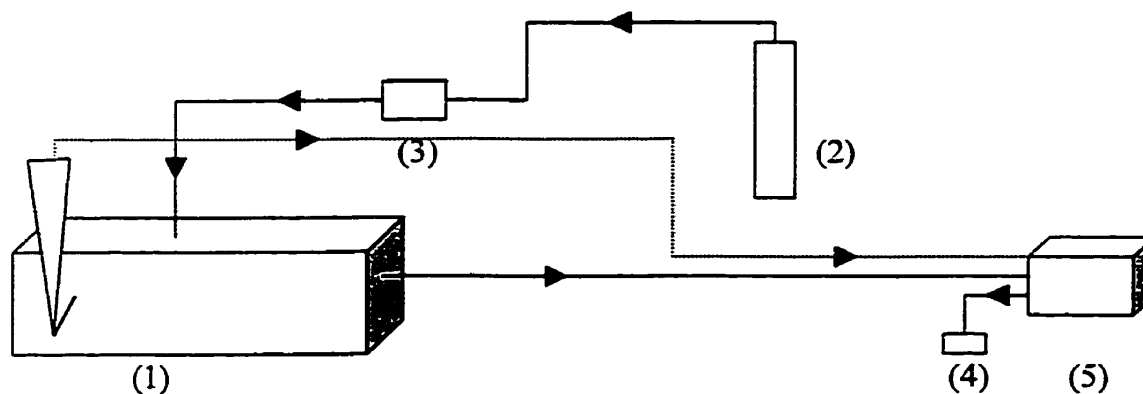

Figure 1. Technique used to adjust the performance of the dilution system

(1) CLIMPAQ

(3) Flowmeter

(4) Pump

(2) CO<sub>2</sub> cylinder

(5) CO<sub>2</sub> measurement device

### Continuous ventilation experiment (Calibration curves)

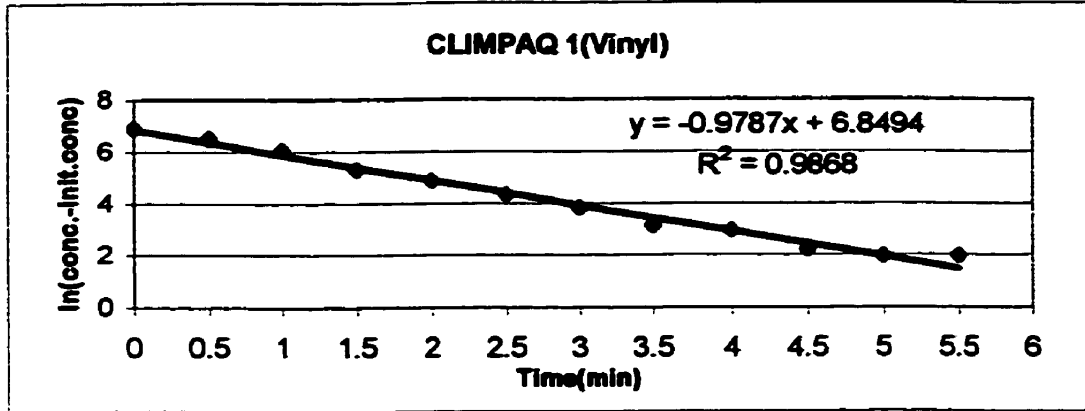

ACH=0.98 min<sup>-1</sup>, Volume=54.6L, Q=0.89 L/s

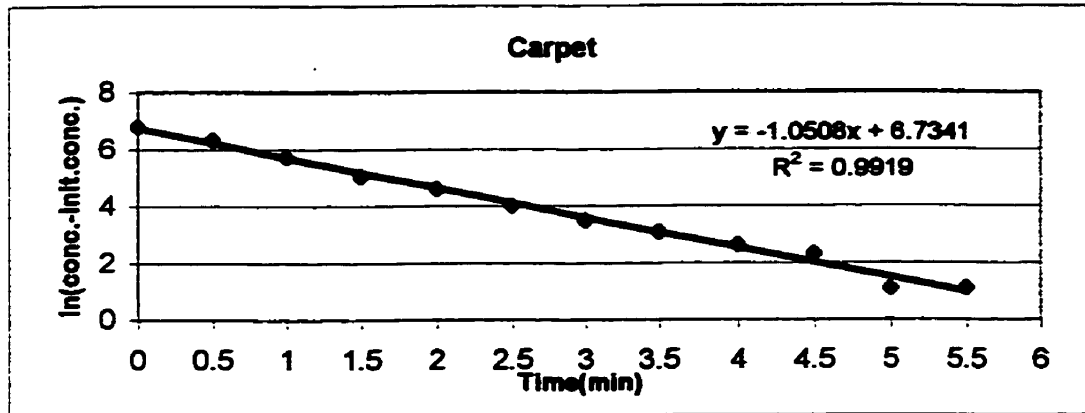

ACH=1.051 min<sup>-1</sup>, Volume=54.6L, Q=0.96 L/s

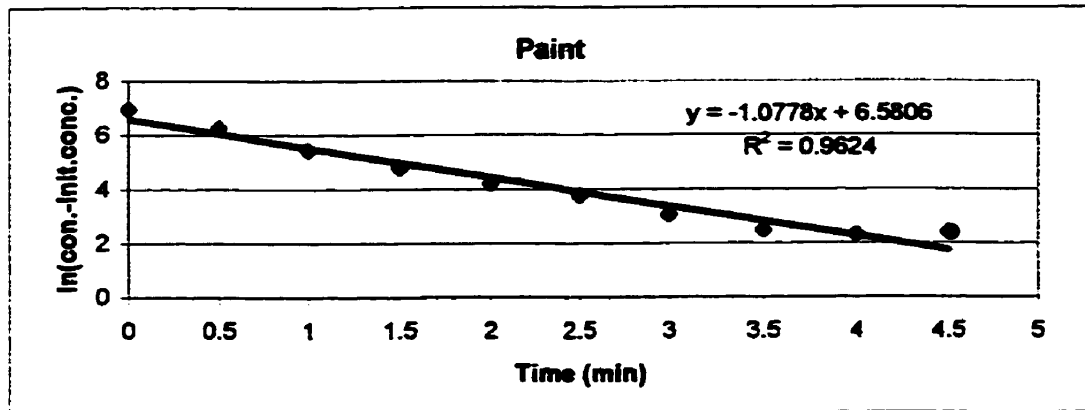

ACH=1.08 min<sup>-1</sup>, Volume=54.6L, Q=0.98 L/s

**CLIMPAQ 1 (Vinyl)**  
(Continuous ventilation)

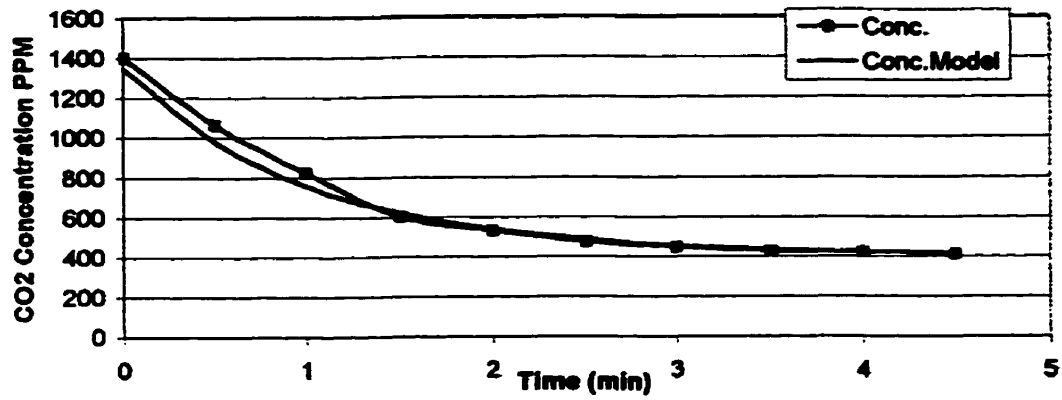

**CLIMPAQ 2 (Carpet)**  
(Continuous ventilation)

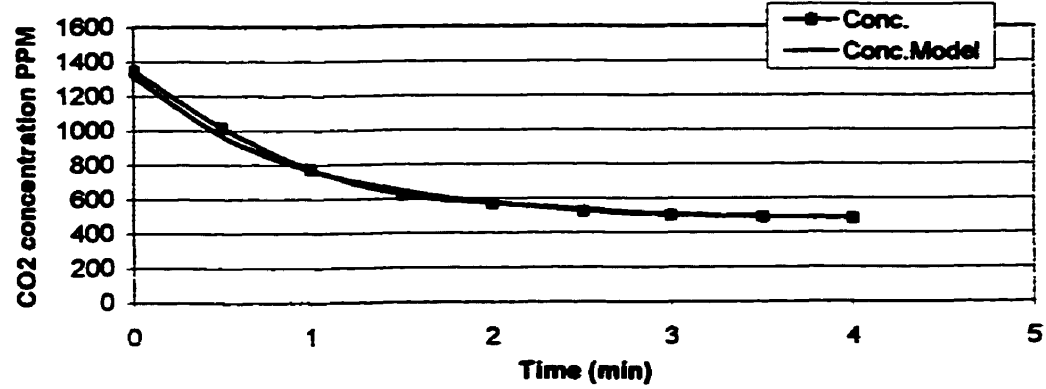

**CLIMPAQ 3 Paint**  
(Continuous ventilation)

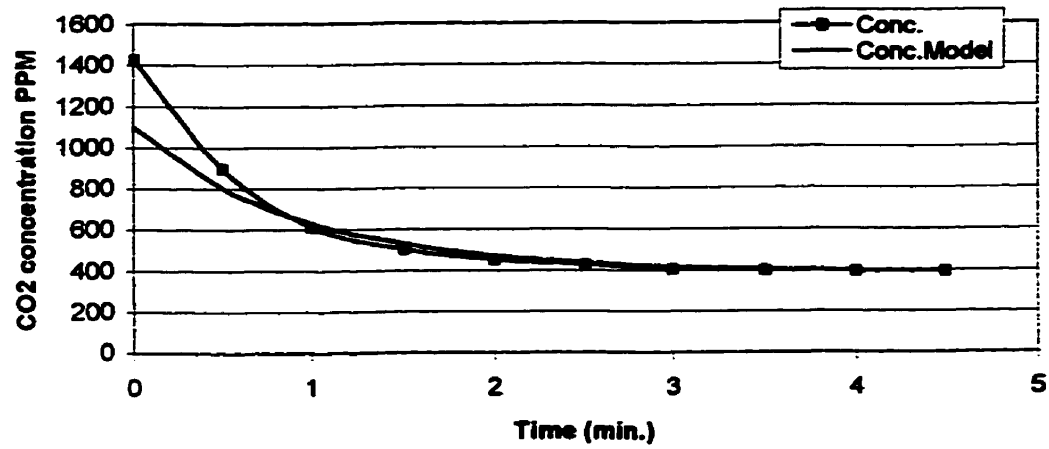

### Intermittent ventilation experiment (Calibration curves)

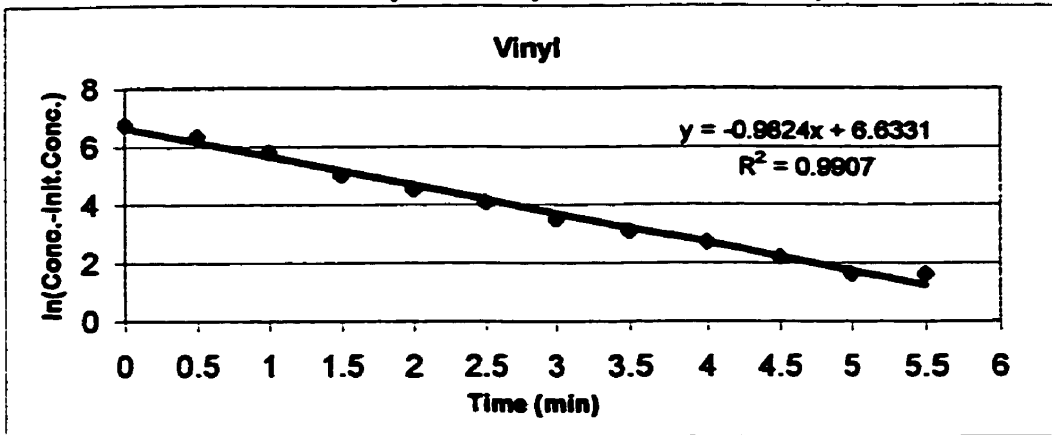

ACH=0.98 min<sup>-1</sup>, Volume=54.6L, Q=0.8918L/s

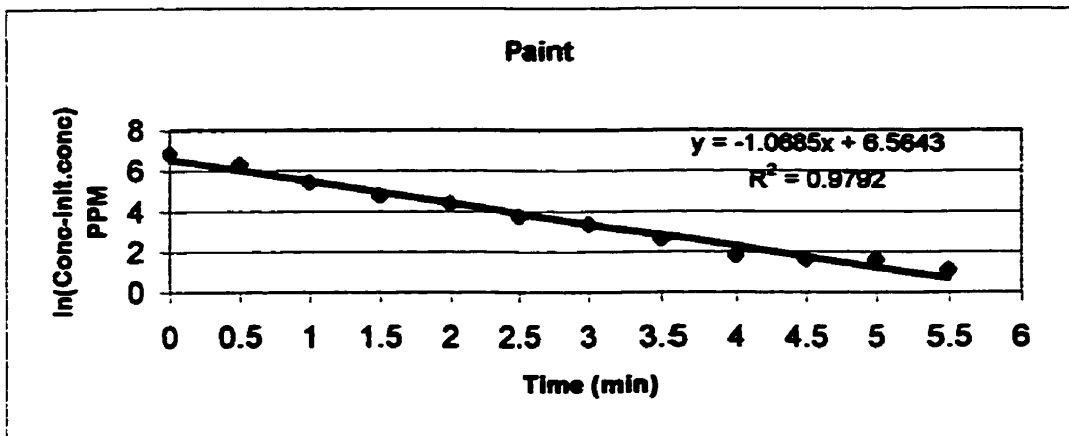

ACH=1.06 min<sup>-1</sup>, Volume=54.6L, Q=0.96 L/s

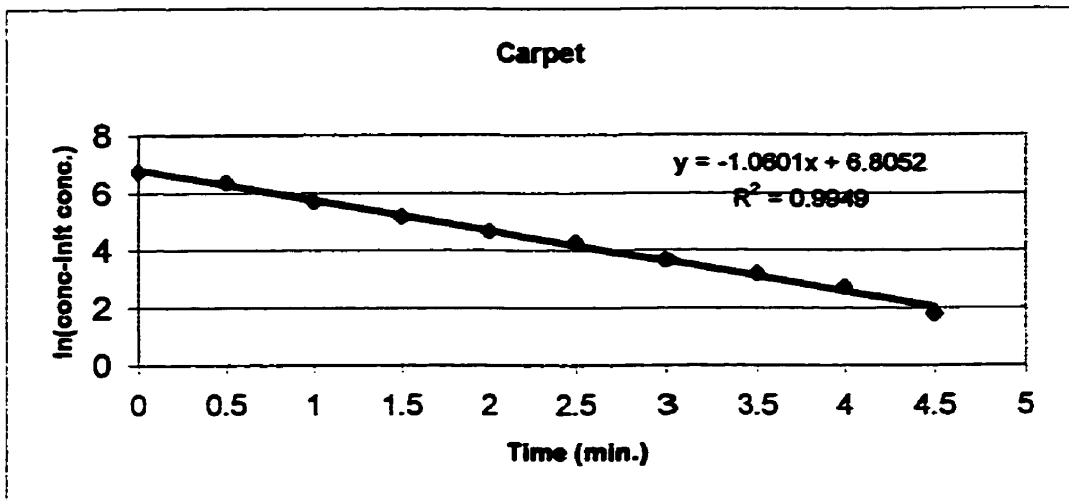

ACH=1.06 min<sup>-1</sup>, Volume=54.6L, Q=0.96L/s

**CLIMPAQ 3 (VINYL)**

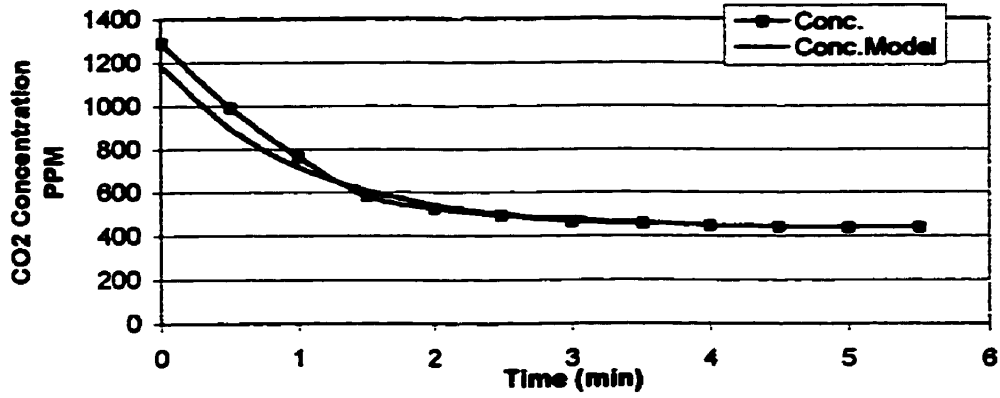

**CLIMPAQ 2 (Paint)**

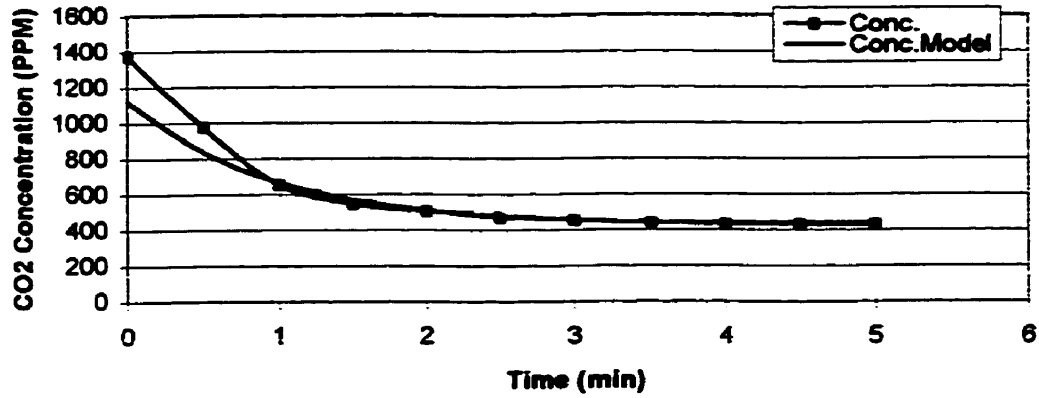

**CLIMPAQ 1 (Carpet)**

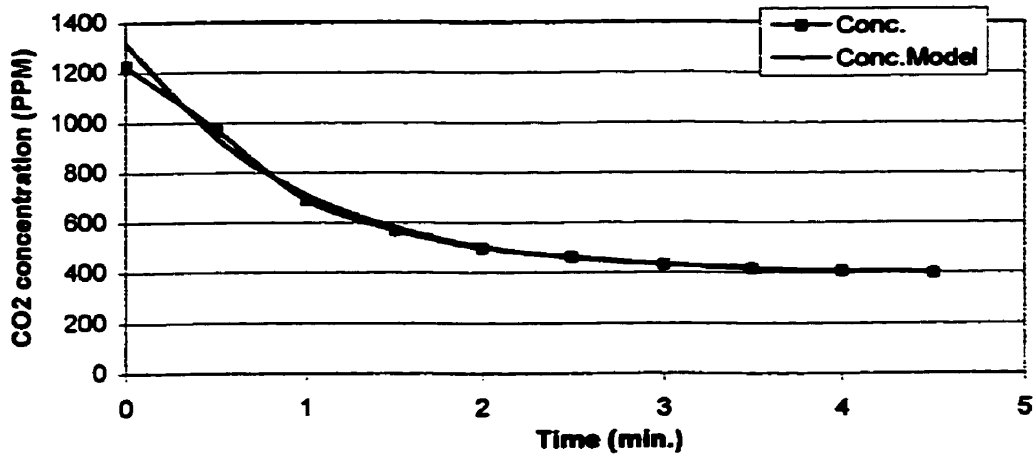

**Dilution experiment ( performed to study the effect of ventilation strategy on perceived air quality)**

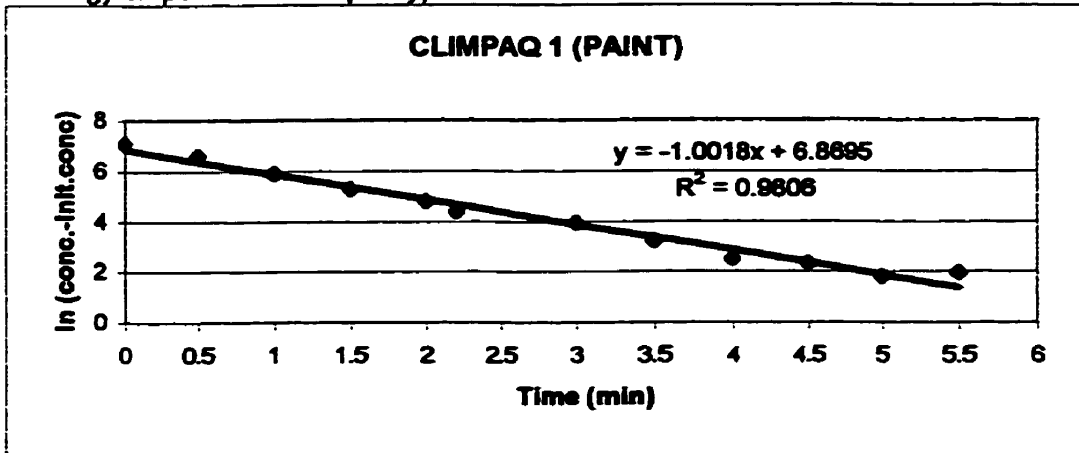

ACH=1.002 min<sup>-1</sup>, Volume=54.6 L, Q=0.91 L/s

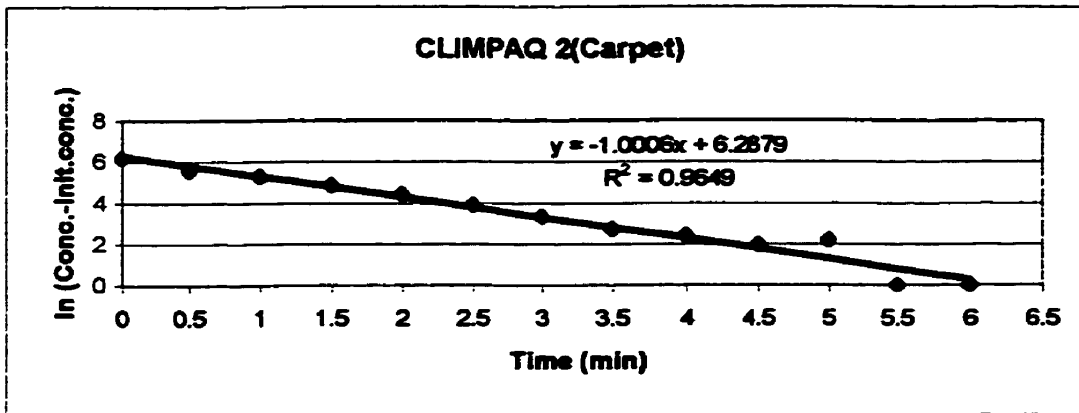

ACH=1.001min<sup>-1</sup>, Volume=54.6L, Q=0.91L/s

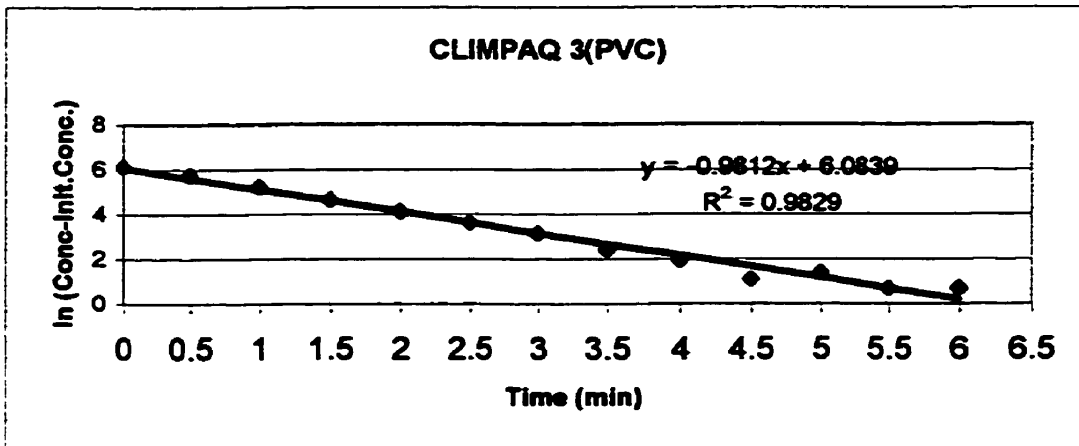

ACH=0.98min<sup>-1</sup>, Volume=54.6L, Q=0.89 L/s



**CLIMPAQ 1(PAINT)**

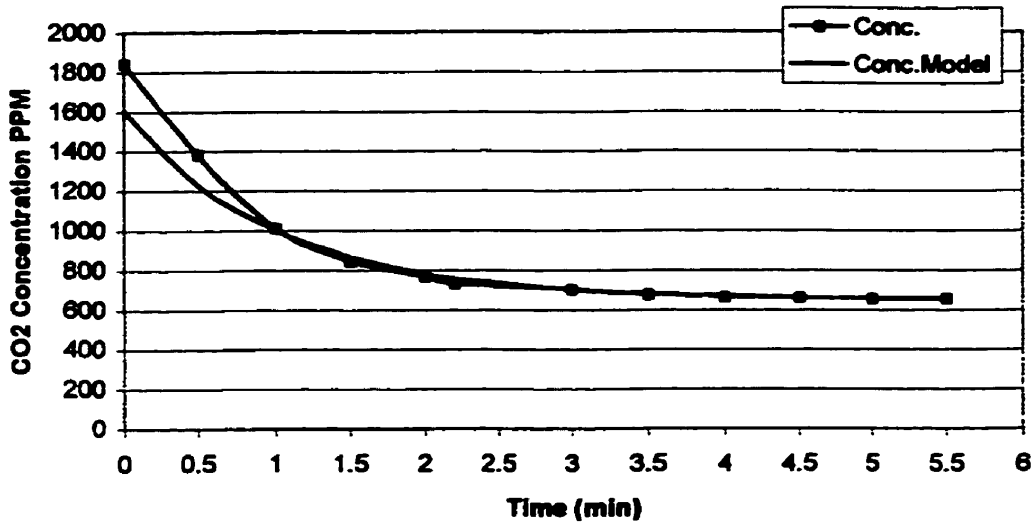

**CLIMPAQ 2(CARPET)**

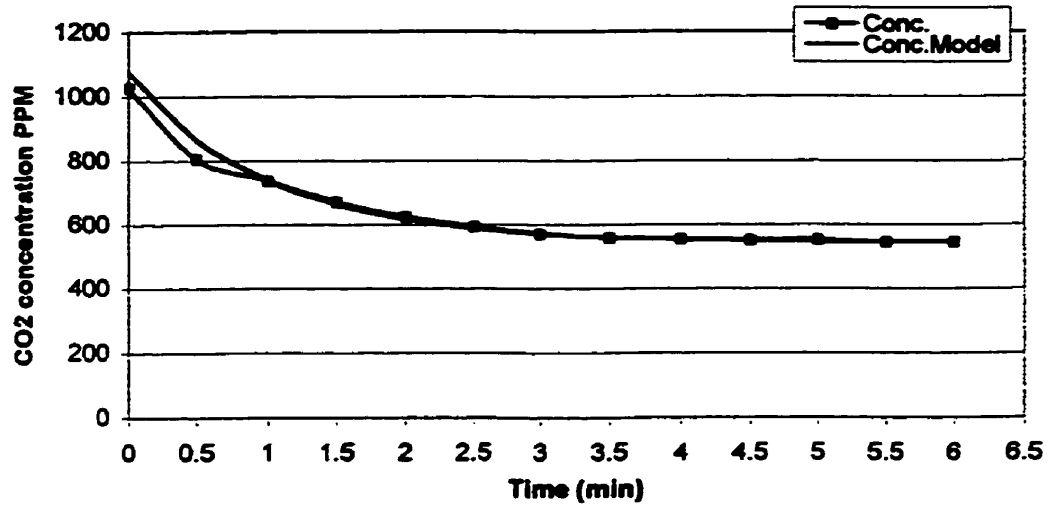

**CLIMPAQ 3 (PVC)**

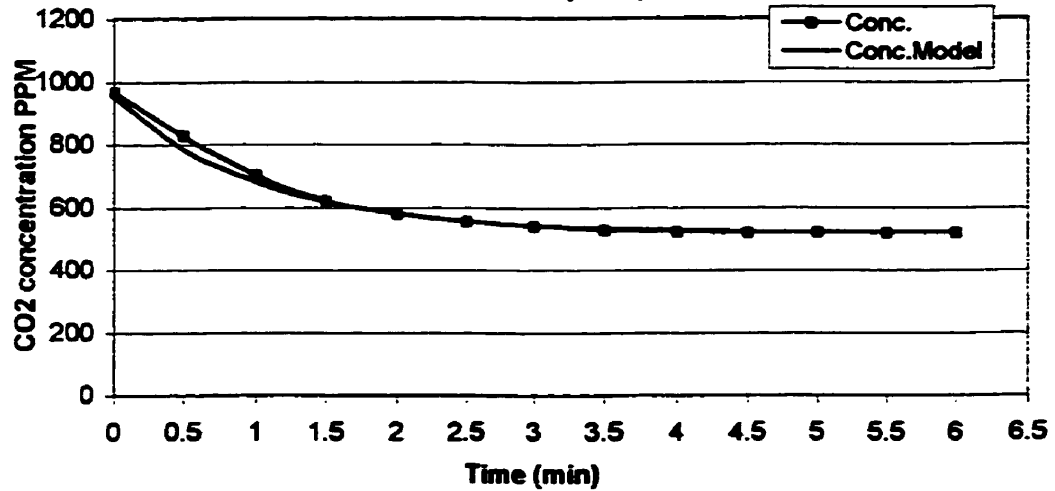

**Dilution experiment ( One material in each test chamber)**

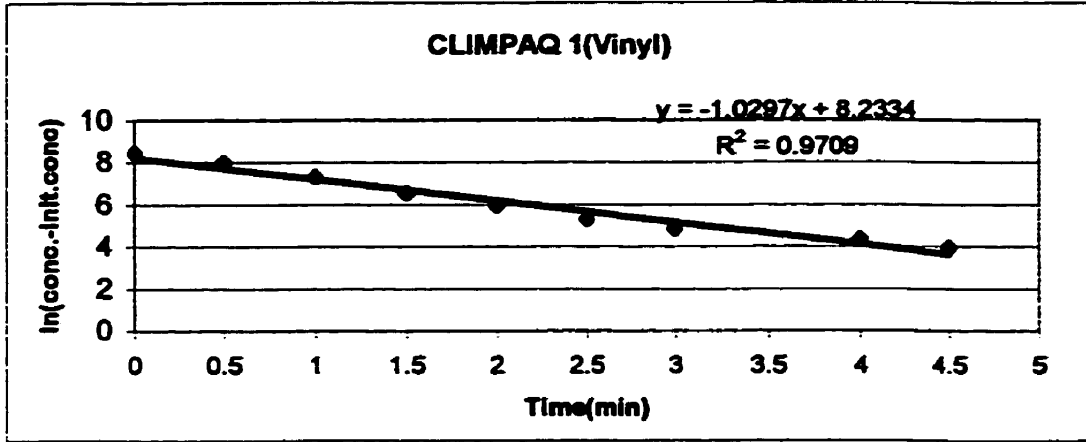

ACH=1.03 min<sup>-1</sup>, Volume=54.6 L, Q=0.94 L/s)

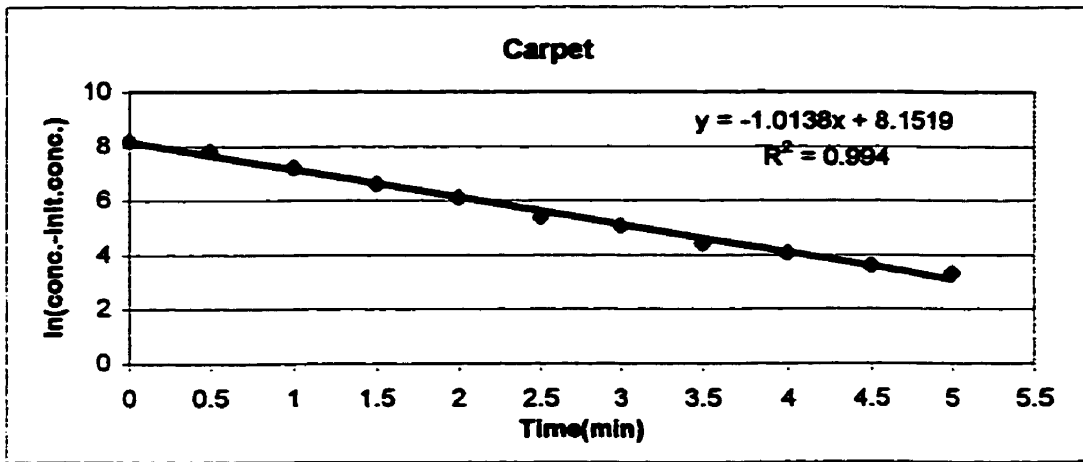

ACH=1.01 min<sup>-1</sup>, Volume=54.6 L, Q=0.92 L/s

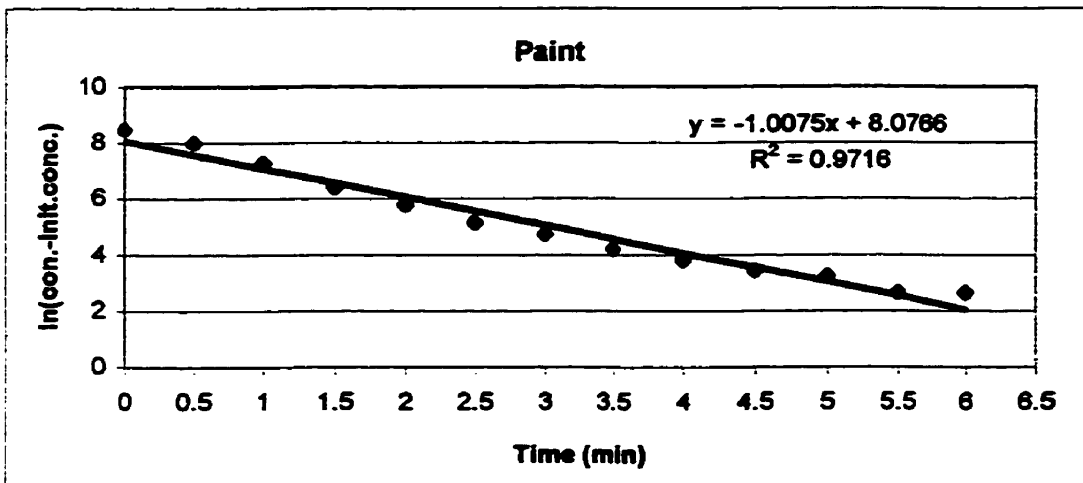

ACH=1.01 min<sup>-1</sup>, Volume=54.6 L, Q=0.92 L/s

CLIMPAQ 1 (Vinyl)

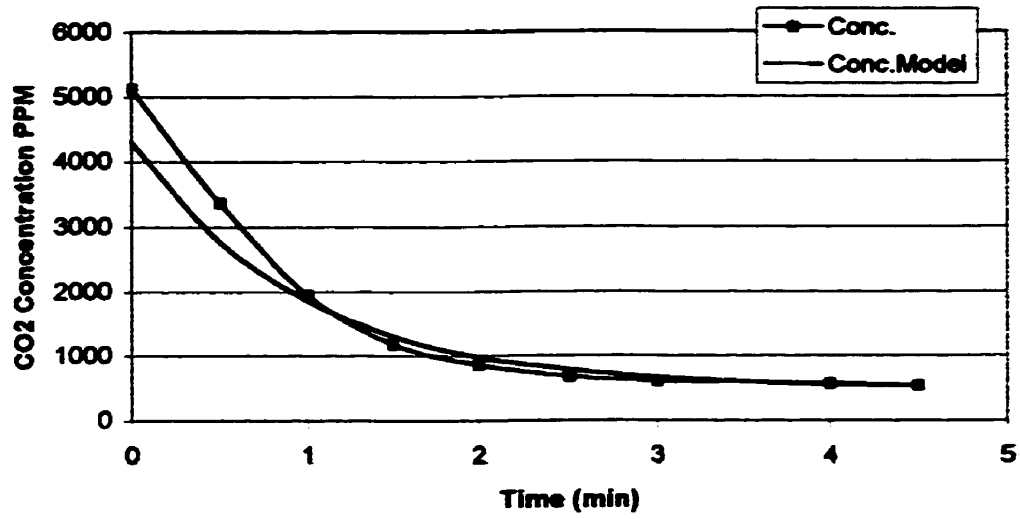

CLIMPAQ 2 (Carpet)

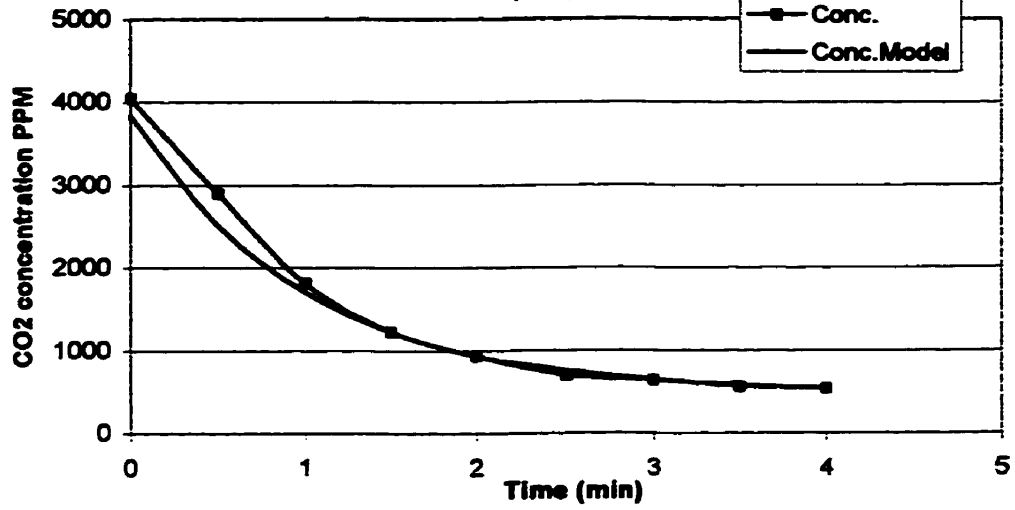

CLIMPAQ 3 Paint

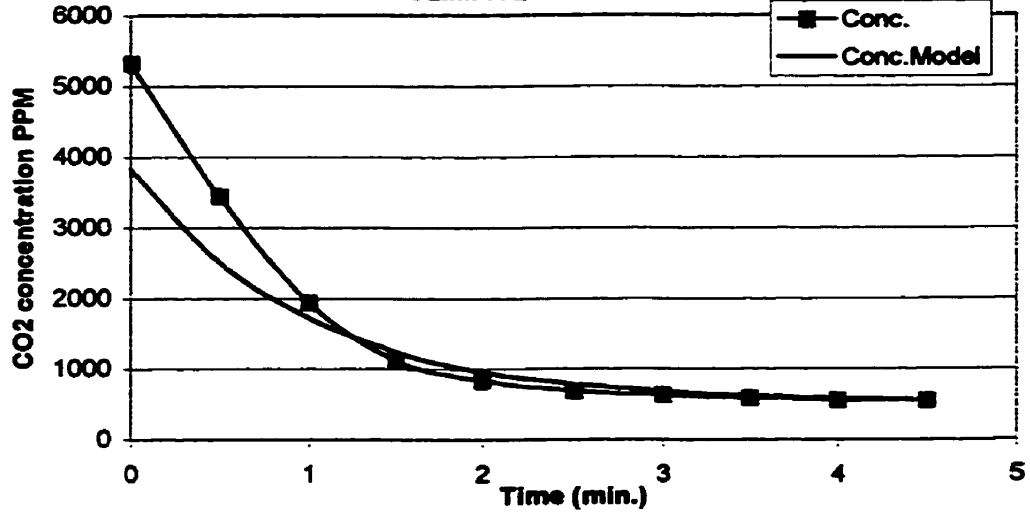

**Dilution experiment ( two different materials in each test chamber)**

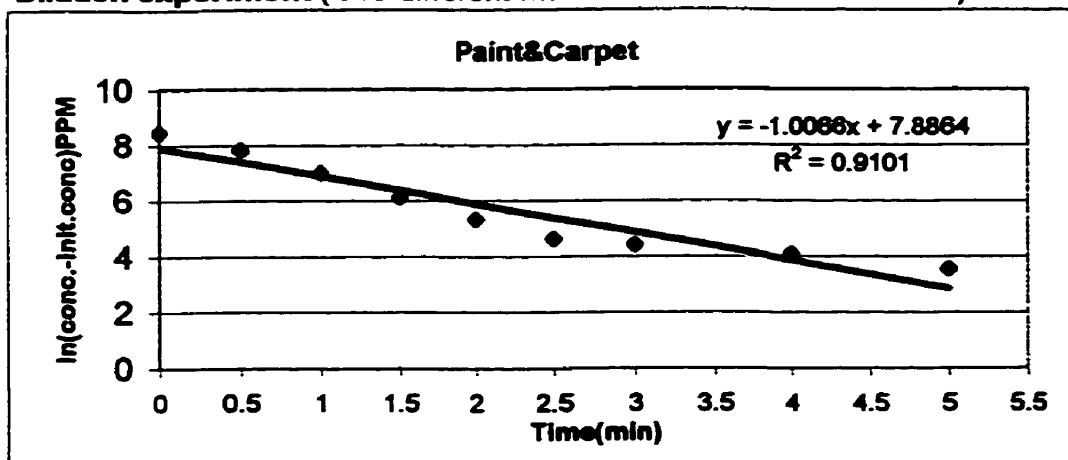

ACH=1.01 min<sup>-1</sup>, Volume=54.6L, Q=0.92L/s

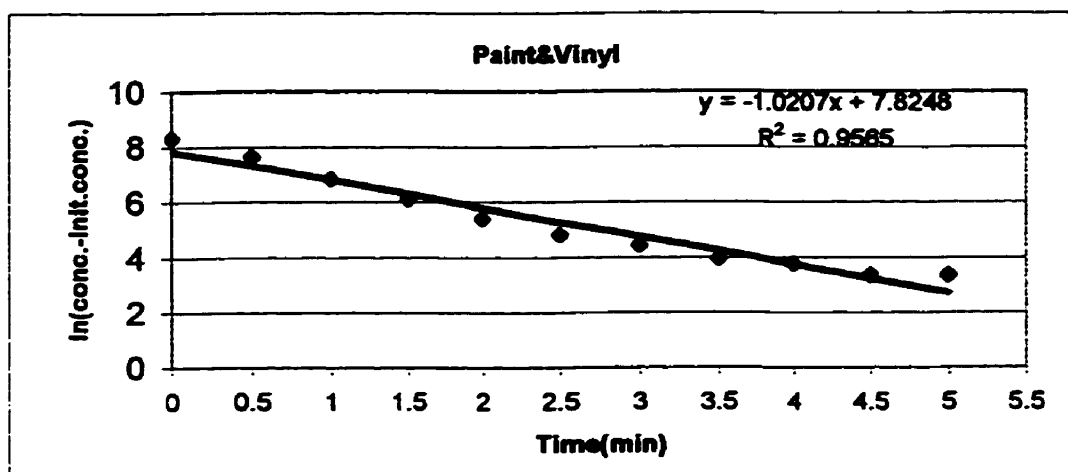

ACH=1.02 min<sup>-1</sup>, Volume=54.6 L, Q=0.93 L/s

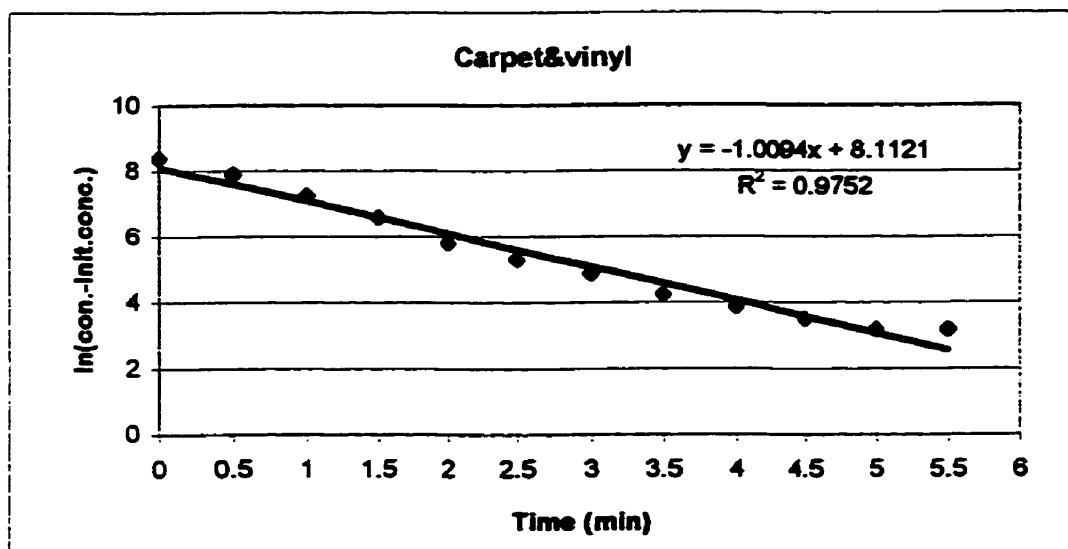

ACH=1.01 min<sup>-1</sup>, Volume=54.6 L, Q=0.92 L/s

(Paint&amp;Carpet)

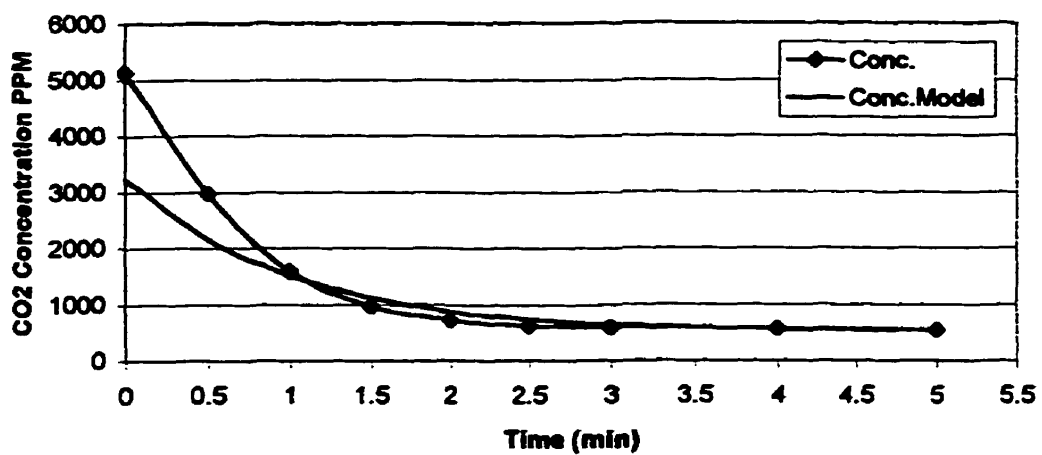

(Carpet &amp; Vinyl)

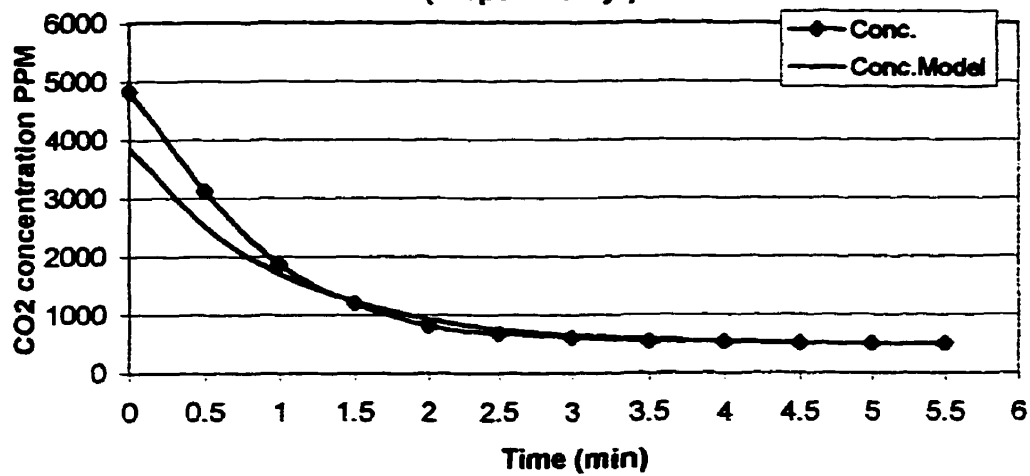

(Paint &amp; Vinyl)

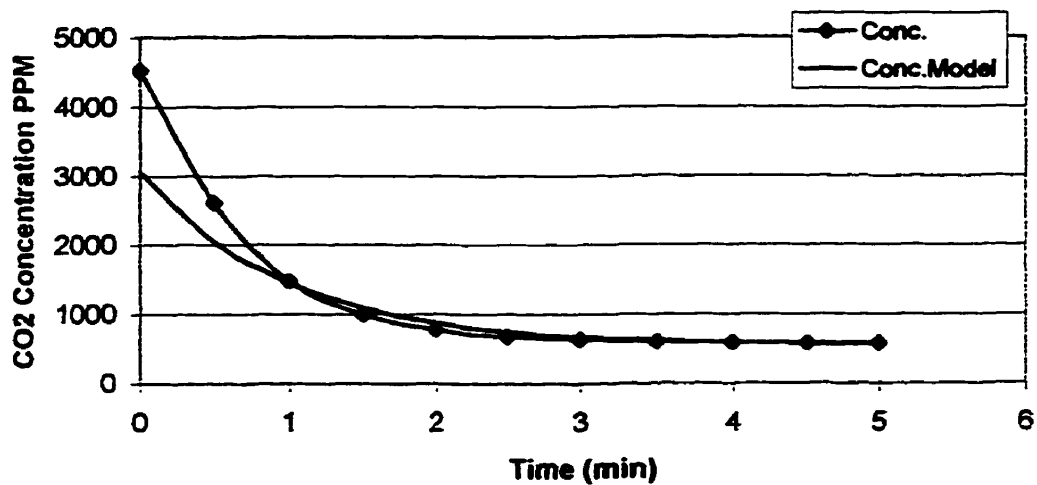

## **APPENDIX II**

## CONTINUOUS VENTILATION EXPERIMENT

Person	CLIMPAQ	Strategy	Acceptability	Odor intensity
1	1	1	1.82	20
2	1	1	0.73	5
3	1	1	1.82	40
4	1	1	-7.64	20
5	1	1	0	15
6	1	1	2	15
7	1	1	7.27	20
10	1	1	-0.55	17
11	1	1	0	13
13	1	1	9.45	15
15	1	1	-9.09	40
16	1	1	-9.27	19
17	1	1	-1.82	13
18	1	1	-5.82	25
19	1	1	-5.09	45
20	1	1	1.82	15
22	1	1	-2	30
23	1	1	-0.73	30
25	1	1	-0.55	12
27	1	1	-9.27	80
28	1	1	-2.73	30
29	1	1	8.55	11
30	1	1	-0.55	25
31	1	1	7.09	11
34	1	1	-1.09	30
36	1	1	5.27	15
38	1	1	-1.45	14
39	1	1	1.45	15
40	1	1	-3.64	30
41	1	1	-2.18	15
43	1	1	-1.27	13
44	1	1	-0.36	50
45	1	1	-3.45	20
46	1	1	0.91	15
47	1	1	-1.27	20
48	1	1	-4	25
49	1	1	-0.55	15
50	1	1	-2.36	12
51	1	1	-6.91	30
52	1	1	1.09	6
53	1	1	7.27	7
54	1	1	5.64	30
55	1	1	5.09	15
56	1	1	1.82	10
57	1	1	-5.27	50
58	1	1	-7.45	26
59	1	1	-1.09	30
60	1	1	-1.09	25
61	1	1	0.91	12
62	1	1	-2	20

-0.61

22.32

MEAN

4.50

13.54

STDEVA

0.64

1.91

STEDA/SORT(50)

1	2	1	1.27	25
2	2	1	-1.27	2
3	2	1	-5.45	15
4	2	1	-9.45	30
5	2	1	8.73	13
6	2	1	8.73	5
7	2	1	7.09	20
10	2	1	0.91	18
11	2	1	10	10
13	2	1	-4.73	40
15	2	1	0.73	20
16	2	1	8.73	11
17	2	1	-0.73	12
18	2	1	-2.36	20

19	2	1	-0.73	35
20	2	1	-0.73	20
22	2	1	-0.73	20
23	2	1	1.82	20
25	2	1	-0.36	11
27	2	1	2.36	2
28	2	1	-4.55	25
29	2	1	10	9
30	2	1	-0.55	25
31	2	1	4.73	15
34	2	1	0	20
36	2	1	9.64	12
38	2	1	-7.09	13
39	2	1	-1.27	15
40	2	1	0.91	20
41	2	1	3.09	15
43	2	1	-1.27	8
44	2	1	0.91	20
45	2	1	-0.55	20
46	2	1	-3.45	22
47	2	1	5.27	20
48	2	1	-1.09	20
49	2	1	-2.36	20
50	2	1	3.27	8
51	2	1	-0.91	25
52	2	1	6	5
53	2	1	9.27	5
54	2	1	1.64	30
55	2	1	-5.45	30
56	2	1	2.36	20
57	2	1	8.91	7
58	2	1	3.64	11
59	2	1	-1.09	20
60	2	1	7.82	30
61	2	1	8.18	6
62	2	1	0.55	15

1.61 17.20  
 4.85 8.49  
 0.69 1.20

MEAN  
 STDEVA  
 STEDV(SQRT(50))

1	3	1	-0.36	35
2	3	1	-9.27	50
3	3	1	-9.09	100
4	3	1	-7.45	30
5	3	1	-1.27	30
6	3	1	-9.64	30
7	3	1	4	40
10	3	1	-4	19
11	3	1	-6.36	13
13	3	1	-2.18	40
15	3	1	-9.09	40
16	3	1	-9.64	20
17	3	1	-4.55	15
18	3	1	-6.91	50
19	3	1	-6.73	50
20	3	1	-7.09	30
22	3	1	-8.73	50
23	3	1	8.73	15
25	3	1	-5.09	18
27	3	1	-8.55	75
28	3	1	-8.18	40
29	3	1	-4.73	30
30	3	1	-2.73	40
31	3	1	-2.55	19
34	3	1	-8.36	50
36	3	1	-2.73	30
38	3	1	-4.73	16
39	3	1	1.27	30
40	3	1	-9.09	50
41	3	1	-4.91	20



43	3	1	-9.09	13
44	3	1	-0.91	60
45	3	1	-8	30
46	3	1	-6.91	28
47	3	1	-9.45	40
48	3	1	-8.73	35
49	3	1	-5.64	30
50	3	1	-5.64	14
51	3	1	-8	35
52	3	1	2	7
53	3	1	-8.18	20
54	3	1	5.82	40
55	3	1	-0.36	20
56	3	1	-2.73	30
57	3	1	0.91	20
58	3	1	-4.73	20
59	3	1	-6.73	40
60	3	1	1.09	23
61	3	1	-1.45	20
62	3	1	-7.82	30

-4.69 32.60  
 4.36 16.85  
 0.62 2.38

MEAN  
 STDEVA  
 STEDV/SQRT(50)

1	4	1	8.36	11
2	4	1	9.45	10
3	4	1	-7.27	20
4	4	1	-3.82	15
5	4	1	10	6
6	4	1	9.27	8
7	4	1	8.91	20
10	4	1	4	13
11	4	1	10	10
13	4	1	10	6
15	4	1	-1.27	2
16	4	1	7.09	13
17	4	1	-0.36	11
18	4	1	7.82	5
19	4	1	2.18	20
20	4	1	10	7
22	4	1	10	8
23	4	1	0.36	25
25	4	1	-0.18	10.5
27	4	1	9.82	10
28	4	1	0	15
29	4	1	9.64	10
30	4	1	5.45	18
31	4	1	7.64	12
34	4	1	9.27	12
36	4	1	10	10
38	4	1	10	7
39	4	1	10	10
40	4	1	6.36	15
41	4	1	9.82	10
43	4	1	1.82	10
44	4	1	-2	40
45	4	1	6.55	15
46	4	1	0.73	15
47	4	1	6	15
48	4	1	1.09	15
49	4	1	7.45	10
50	4	1	7.64	6
51	4	1	-0.55	20
52	4	1	0	7
53	4	1	-4.36	15
54	4	1	9.27	10
55	4	1	-9.09	50
56	4	1	9.82	1
57	4	1	6.36	6
58	4	1	-0.36	13

59	4	1	10	10
60	4	1	9.09	7
61	4	1	-1.27	15
62	4	1	8	10
			4.97	12.79
			5.28	8.26
			0.75	1.17

MEAN  
STDEVA  
STEDA/SQRT(50)

**INTERMITTENT VENTILATION EXPERIMENT**

Person	CLIMPAQ	Strategy	Acceptability	Odor intensity
1	1	2	-1.64	30
2	1	2	-0.91	20
3	1	2	-8.55	80
4	1	2	-8.18	20
5	1	2	-2.73	30
6	1	2	-3.82	30
7	1	2	-1.82	30
8	1	2	-10	14
9	1	2	-1.27	13
10	1	2	-0.36	15
11	1	2	0	12
12	1	2	-1.64	15
13	1	2	-6	25
14	1	2	0.55	9
15	1	2	-5.45	40
16	1	2	-8.45	24
17	1	2	-5.27	15
18	1	2	-8.18	80
19	1	2	-7.27	55
20	1	2	0.73	20
21	1	2	-2.91	20
22	1	2	2	20
23	1	2	0.73	20
24	1	2	-6.91	5
25	1	2	-1.82	17
26	1	2	-5.27	20
27	1	2	-3.64	30
28	1	2	-1.45	17
29	1	2	0.18	15
30	1	2	-3.27	30
31	1	2	0.91	11
32	1	2	1.45	20
33	1	2	-3.45	20
34	1	2	-2.36	20
35	1	2	-1.09	15
36	1	2	0.91	30
37	1	2	1.27	15
38	1	2	5.27	11
39	1	2	4.91	15
40	1	2	-3.27	30
41	1	2	-3.27	15
42	1	2	-4.91	40
			-2.55	24.12
			3.64	15.79
			0.56	2.44

MEAN  
STDEVA  
STEDA/SQRT(42)

1	2	2	-4	40
2	2	2	-3.64	20
3	2	2	1.64	20
4	2	2	-7.27	15
5	2	2	-0.73	20
6	2	2	2	20
7	2	2	2.55	40
8	2	2	9.09	12
9	2	2	-1.45	11
10	2	2	-0.55	18
11	2	2	-5.64	15
12	2	2	-4	30

13	2	2	3.45	30
14	2	2	-6.36	20
15	2	2	0.73	40
16	2	2	1.45	15
17	2	2	-4.73	20
18	2	2	-4.55	40
19	2	2	-6.55	60
20	2	2	-0.91	28
21	2	2	-1.27	15
22	2	2	-5.45	35
23	2	2	-0.73	30
24	2	2	2.36	12
25	2	2	-0.55	11
26	2	2	5.09	15
27	2	2	-1.45	15
28	2	2	6.91	30
29	2	2	5.82	8
30	2	2	-2	30
31	2	2	9.09	12
32	2	2	-4.55	50
33	2	2	-1.09	14
34	2	2	1.82	15
35	2	2	-5.27	20
36	2	2	6.36	20
37	2	2	-5.09	25
38	2	2	0.91	15
39	2	2	-3.27	20
40	2	2	8.55	10
41	2	2	2.73	15
42	2	2	-0.91	30

-0.27 22.88  
 4.45 11.61  
 0.69 1.79

MEAN  
 STDEVA  
 STEDA/SQRT(42)

1	3	2	-0.91	25
2	3	2	-8.73	60
3	3	2	-9.64	100
4	3	2	-9.45	40
5	3	2	-9.64	70
6	3	2	-9.64	50
7	3	2	-1.64	50
8	3	2	-7.82	8
9	3	2	-9.64	20
10	3	2	-4.18	20
11	3	2	-7.09	15
12	3	2	-2	15
13	3	2	-3.45	50
14	3	2	-6.91	22
15	3	2	-9.45	50
16	3	2	-3.64	19
17	3	2	-10	30
18	3	2	-9.27	90
19	3	2	-4.18	50
20	3	2	9.09	15
21	3	2	-8.55	30
22	3	2	-9.64	50
23	3	2	-1.45	35
24	3	2	-0.55	9
25	3	2	-3.64	25
26	3	2	-9.45	100
27	3	2	-7.09	60
28	3	2	-8.18	40
29	3	2	-4.91	25
30	3	2	-7.64	40
31	3	2	-2.55	14
32	3	2	-0.73	40
33	3	2	1.27	12
34	3	2	-8.91	40
35	3	2	-6.36	20
36	3	2	0.91	20

37	3	2	-9.09	15
38	3	2	-9.09	20
39	3	2	0	20
40	3	2	-9.64	40
41	3	2	-6.36	20
42	3	2	-7.27	50
			-5.65	36.29
			4.23	23.13
			0.65	3.57
				MEAN
				STDEVA
				STEDA/SQRT(42)
1	4	2	1.27	15
2	4	2	8.36	5
3	4	2	5.45	5
4	4	2	-6.36	15
5	4	2	10	5
6	4	2	9.45	8
7	4	2	9.27	15
8	4	2	9.09	12
9	4	2	8.73	15
10	4	2	1.64	12
11	4	2	9.64	10
12	4	2	-1.45	15
13	4	2	9.82	15
14	4	2	-4.55	18
15	4	2	-1.09	20
16	4	2	6.36	13
17	4	2	-0.91	13
18	4	2	-3.27	8
19	4	2	1.82	25
20	4	2	10	7
21	4	2	4.18	8
22	4	2	8.73	12
23	4	2	8.73	10
24	4	2	5.45	15
25	4	2	-1.82	15
26	4	2	5.09	10
27	4	2	5.09	2
28	4	2	4	13
29	4	2	8.73	10
30	4	2	0.73	20
31	4	2	9.64	5
32	4	2	0	25
33	4	2	6.36	20
34	4	2	9.09	10
35	4	2	0.73	5
36	4	2	9.09	10
37	4	2	7.82	20
38	4	2	9.09	11
39	4	2	5.09	10
40	4	2	5.09	20
41	4	2	0	12
42	4	2	0.55	20
			4.64	12.71
			4.65	5.54
			0.72	0.85
				MEAN
				STDEVA
				STEDA/SQRT(42)

CLIMPAQ	Material
1	Carpet
2	Paint
3	PVC
4	Supply

Strategy 1 Continuous ventilation  
Strategy 2 Intermittent ventilation

## Dilution Experiment

## Paint

Person	Round	CLMPAQ	Acceptability	Odor intensity
1	1	1	-4.18	30
2	1	1	-5.45	30
3	1	1	-1.82	35
10	1	1	-3.64	20
13	1	1	0.36	40
15	1	1	-5.45	40
16	1	1	-1.27	15
17	1	1	-0.36	12
19	1	1	0.55	35
23	1	1	1.09	18
25	1	1	-3.64	14
28	1	1	-2.91	20
29	1	1	5.09	8
30	1	1	-3.64	28
31	1	1	8.00	14
35	1	1	2.18	18
36	1	1	9.09	11
39	1	1	-2.00	20
40	1	1	5.64	15
46	1	1	-1.64	15
49	1	1	-1.45	15
55	1	1	0.91	
56	1	1	6.91	20
57	1	1	1.82	15
59	1	1	-0.55	19
63	1	1	-0.73	20
66	1	1	-4.36	40
67	1	1	3.82	30
68	1	1	-1.27	14

0.04 21.82

MEAN

3.95 9.53

STDEVA

0.73 1.80

STEDA/SQRT(29)

1	2	1	-2.18	30
2	2	1	-1.64	20
3	2	1	-2.36	40
10	2	1	0.36	15
13	2	1	1.27	25
15	2	1	-4.55	20
16	2	1	-1.45	14
17	2	1	0.00	10
19	2	1	-2.55	45
23	2	1	5.45	14
25	2	1	-3.64	14
28	2	1	-2.91	17
29	2	1	1.82	9
30	2	1	-2.73	28
31	2	1	8.73	12
35	2	1	-0.91	18
36	2	1	9.09	12
39	2	1	-4.55	18
40	2	1	4.36	15
46	2	1	-0.55	12
49	2	1	1.45	15
55	2	1	5.45	
56	2	1	9.45	3
57	2	1	1.82	20
59	2	1	-0.73	25
63	2	1	4.55	15
66	2	1	-2.55	20
67	2	1	3.27	30
68	2	1	-3.64	16

0.70 19

MEAN

4.09 9.14

STDEVA

0.76 1.73

STEDA/SQRT(29)

1	3	1	-0.91	25
2	3	1	-1.82	30
3	3	1	0.55	20
10	3	1	-0.36	13
13	3	1	8.18	25
15	3	1	-2.00	10
16	3	1	-2.36	13
17	3	1	-0.73	10
19	3	1	3.09	21
23	3	1	7.09	14
25	3	1	-0.55	11.5
28	3	1	-4.73	25
29	3	1	0.00	7
30	3	1	1.09	15
31	3	1	7.45	12
35	3	1	5.09	12
36	3	1		
39	3	1	5.82	12
40	3	1	5.82	12
46	3	1	1.09	12
49	3	1	-3.45	40
55	3	1	7.82	
56	3	1	6.18	15
57	3	1	7.64	5
59	3	1	-0.73	15
63	3	1	0.55	15
66	3	1	0.00	18
67	3	1	9.09	15
68	3	1	-2.91	13

2.00 16.13 MEAN  
 4.15 7.52 STDEVA  
 0.78 1.45 STEDA/SQRT(29)

1	4	1	-1.09	20
2	4	1	-2.73	30
3	4	1	-0.91	30
10	4	1	-4.55	20
13	4	1	2.55	22
15	4	1	6.00	0
16	4	1	-1.09	11
17	4	1	-0.36	11
19	4	1	1.82	28
23	4	1	5.45	15
25	4	1	-0.36	10.5
28	4	1	-3.45	14
29	4	1	4.36	9
30	4	1	1.09	15
31	4	1	7.09	12
35	4	1	-1.27	13
36	4	1	9.45	11
39	4	1	10.00	11
40	4	1	8.55	12
46	4	1	-0.55	12
49	4	1	-1.27	15
55	4	1	6.91	
56	4	1	4.55	13
57	4	1	4.91	20
59	4	1	-0.73	20
63	4	1	0.36	13
66	4	1	0.00	19
67	4	1	8.18	25
68	4	1	-1.27	14

2.13 15.91 MEAN  
 4.17 6.80 STDEVA  
 0.77 1.28 STEDA/SQRT(29)

1	5	1	-1.82	30
2	5	1	-1.27	20
3	5	1	-1.82	20
10	5	1	-2.00	15
13	5	1	2.73	12

15	5	1	8.73	0
16	5	1	-0.73	11
17	5	1	0.36	11
19	5	1	0.55	30
23	5	1	5.09	16
25	5	1	-0.36	12
28	5	1	-1.27	10
29	5	1	4.55	8
30	5	1	0.73	18
31	5	1	8.73	10
35	5	1	1.64	12
36	5	1	8.91	10
39	5	1	10.00	10
40	5	1	9.09	12
46	5	1	-0.55	10
49	5	1	0.00	15
55	5	1	1.82	
56	5	1	1.09	20
57	5	1	4.55	15
59	5	1	-0.36	15
63	5	1	2.18	14
66	5	1	0.73	18
67	5	1	6.55	20
68	5	1	2.55	10.5

2.43 14.45 MEAN  
 3.76 6.23 STDEVA  
 0.70 1.18 STEDA/SQRT(29)

**Carpet**

Person	Round	CLIMPAQ	Acccp.	Odor intensity
1	1	2	-2.36	20
2	1	2	-1.64	20
3	1	2	-8.18	95
10	1	2	-3.45	20
13	1	2	1.64	40
15	1	2	-8.18	40
16	1	2	-7.27	19
17	1	2	-2.55	13
19	1	2	-1.45	45
23	1	2	4.55	15
25	1	2	-1.82	13
28	1	2	-1.45	17
29	1	2	-2.55	6
30	1	2	-4.00	30
31	1	2	1.64	12
35	1	2	0.36	25
36	1	2	1.09	20
39	1	2	0.00	20
40	1	2	-2.18	30
46	1	2	-3.64	20
49	1	2	-4.36	20
55	1	2		
56	1	2	4.91	15
57	1	2	-1.64	30
59	1	2	-1.64	30
63	1	2	-0.18	15
66	1	2	-2.18	30
67	1	2	2.91	35
68	1	2	0.91	13

-1.53 25.29 MEAN  
 3.26 16.68 STDEVA  
 0.62 3.15 STEDA/SQRT(29)

1	2	2	-1.27	25
2	2	2	-2.55	30
3	2	2	-1.45	30
10	2	2	4.00	14
13	2	2	9.45	8
15	2	2	-7.27	10
16	2	2	-2.55	16
17	2	2	0.55	10

19	2	2	1.09	30
23	2	2	-0.91	25
25	2	2	-1.82	13
28	2	2	-2.55	15
29	2	2	2.55	8
30	2	2	-0.91	21
31	2	2	2.55	16
35	2	2	0.73	15
36	2	2	7.64	15
39	2	2	4.73	15
40	2	2	0.55	30
46	2	2	-1.64	16
49	2	2	-1.64	20
55	2	2		
56	2	2	2.91	15
57	2	2	-2.73	8
59	2	2	-7.64	50
63	2	2	-0.36	16
66	2	2	-0.36	17
67	2	2	5.82	25
68	2	2	-3.27	16

0.13 18.89  
 3.88 9.17  
 0.73 1.73

MEAN  
 STDEVA  
 STEDASQRT(29)

1	3	2	1.27	13
2	3	2	7.82	15
3	3	2	-1.82	30
10	3	2	-2.18	15
13	3	2	10.00	7
15	3	2	-3.64	10
16	3	2	-4.55	16
17	3	2	0.73	10
19	3	2	3.82	24
23	3	2	4.91	15
25	3	2	-0.91	11
28	3	2	-3.09	18
29	3	2	-2.18	8
30	3	2	1.27	15
31	3	2	7.27	13
35	3	2	7.09	11
36	3	2		
39	3	2	8.18	11
40	3	2	-2.55	25
46	3	2	0.00	14
49	3	2	-1.27	25
55	3	2		
56	3	2	5.45	10
57	3	2	9.09	3
59	3	2	0.91	10
63	3	2	2.55	14
66	3	2	-0.36	18
67	3	2	7.82	15
68	3	2	1.09	11

2.10 14.33  
 4.39 6.03  
 0.85 1.16

MEAN  
 STDEVA  
 STEDASQRT(29)

1	4	2	5.82	12
2	4	2	0.36	20
3	4	2	-4.55	40
10	4	2	0.36	12
13	4	2	9.82	6
15	4	2	-1.09	10
16	4	2	-4.00	13
17	4	2	0.73	10
19	4	2	3.27	25
23	4	2	5.09	16
25	4	2	-0.36	11
28	4	2	-4.55	20
29	4	2	2.18	7



30	4	2	-0.36	20
31	4	2	5.27	14
35	4	2	3.64	11
36	4	2	9.27	11
39	4	2	8.73	11
40	4	2	2.36	20
46	4	2	0.00	13
49	4	2	-0.91	15
55	4	2		
56	4	2	2.91	20
57	4	2	2.36	10
59	4	2	9.09	10
63	4	2	5.27	12
66	4	2	0.36	15
67	4	2	5.09	20
68	4	2	-0.73	14

2.34 14.93  
4.03 6.73  
0.76 1.27

MEAN  
STDEVA  
STEDA/SQRT(29)

1	5	2	1.45	15
2	5	2	-4.00	30
3	5	2	-0.55	15
10	5	2	1.09	12
13	5	2	10.00	10
15	5	2	6.91	1
16	5	2	-5.64	14
17	5	2	0.73	12
19	5	2	2.91	25
23	5	2	3.64	18
25	5	2	-0.36	13
28	5	2	-0.91	10
29	5	2	7.27	9
30	5	2	0.55	18
31	5	2	6.18	14
35	5	2	1.45	11
36	5	2	10.00	10
39	5	2	9.64	10
40	5	2	8.55	13
46	5	2	-1.27	13
49	5	2	-1.45	15
55	5	2		
56	5	2	9.27	5
57	5	2	3.09	10
59	5	2	1.09	12
63	5	2	6.91	13
66	5	2	0.73	18
67	5	2	7.64	25
68	5	2	2.55	10.5

3.12 13.63  
4.40 5.89  
0.83 1.11

MEAN  
STDEVA  
STEDA/SQRT(29)

PVC

Person	Round	CLIMPAQ	Accept.	Odor intensity
1	1	3	-1.64	25
2	1	3	-9.09	50
3	1	3	-9.64	100
10	1	3	-3.64	25
13	1	3	0.91	25
15	1	3	-9.09	50
16	1	3	-6.36	18
17	1	3	-4.55	15
19	1	3	-3.64	50
23	1	3	-1.45	25
25	1	3	-5.82	15
28	1	3	-4.73	25
29	1	3	-8.18	2
30	1	3	-9.09	40
31	1	3	-2.55	16
35	1	3	-6.00	30

36	1	3	0.55	20
39	1	3	2.00	20
40	1	3	-8.45	60
46	1	3	-2.00	25
49	1	3	-5.45	30
55	1	3	-8.91	
56	1	3	-3.64	30
57	1	3	-4.00	40
59	1	3	-8.09	60
63	1	3	-4.91	25
66	1	3	-0.73	20
67	1	3	0.36	40
68	1	3	-4.55	16

-4.63 32.04  
 3.49 19.56  
 0.65 3.70

MEAN  
 STDEVA  
 STEDASQRT(29)

1	2	3	-0.73	15
2	2	3	-8.09	50
3	2	3	-8.00	90
10	2	3	-2.73	20
13	2	3	1.09	30
15	2	3	-8.27	50
16	2	3	-6.55	18.5
17	2	3	-3.64	15
19	2	3	-3.64	45
23	2	3	0.91	18
25	2	3	-3.64	14
28	2	3	-5.82	30
29	2	3	-3.64	5
30	2	3	-4.55	35
31	2	3	6.36	12
35	2	3	0.91	18
36	2	3	0.73	20
39	2	3	0.00	20
40	2	3	-8.18	50
46	2	3	-3.82	22
49	2	3	-7.27	30
55	2	3	-3.64	
56	2	3	-2.73	20
57	2	3	-5.45	40
59	2	3	-7.45	50
63	2	3	0.73	14
66	2	3	-5.09	30
67	2	3	0.73	55
68	2	3	0.73	14

-3.20 29.66  
 3.81 18.48  
 0.71 3.49

MEAN  
 STDEVA  
 STEDASQRT(29)

1	3	3	0.55	15
2	3	3	-1.64	20
3	3	3	-9.09	90
10	3	3	0.36	15
13	3	3	9.45	14
15	3	3	-3.27	10
16	3	3	-8.18	19
17	3	3	-0.73	11
19	3	3	-1.09	31
23	3	3	2.91	18
25	3	3	-0.55	10.5
28	3	3	-4.00	15
29	3	3	-8.00	3
30	3	3	-2.00	25
31	3	3	7.64	11
35	3	3	1.82	18
36	3	3		
39	3	3	3.64	14
40	3	3	-7.27	30
46	3	3	-3.64	22
49	3	3	-0.91	15

55	3	3	-1.82	
56	3	3	3.27	20
57	3	3	-4.00	30
58	3	3	-4.91	40
63	3	3	-0.36	18
66	3	3	-0.73	20
67	3	3	6.73	25
68	3	3	0.91	11
			-0.89	21.13
			4.59	15.87
			0.87	3.05

MEAN  
STDEVA  
STEDV/SQRT(29)

1	4	3	7.27	11
2	4	3	-0.91	20
3	4	3	-0.91	30
10	4	3	0.18	12
13	4	3	8.18	13
15	4	3	-1.27	10
16	4	3	-1.27	12
17	4	3	-0.91	12
19	4	3	-2.00	35
23	4	3	1.82	20
25	4	3	-0.36	10.8
28	4	3	-0.36	9
29	4	3	-6.36	3
30	4	3	-0.91	25
31	4	3	4.00	15
35	4	3	1.82	20
36	4	3	8.55	13
39	4	3	7.82	12
40	4	3	1.09	30
46	4	3	-1.27	18
49	4	3	-2.55	25
55	4	3	-0.91	
56	4	3	2.91	18
57	4	3	-1.27	15
59	4	3	-5.45	40
63	4	3	2.36	13
66	4	3	-0.91	20
67	4	3	1.45	45
68	4	3	0.91	11

MEAN  
STDEVA  
STEDV/SQRT(29)

1	5	3	1.09	20
2	5	3	7.82	10
3	5	3	-0.73	20
10	5	3	0.00	13
13	5	3	9.45	13
15	5	3	9.09	0
16	5	3	-4.00	14
17	5	3	0.36	11
19	5	3	-1.27	27
23	5	3	2.36	18
25	5	3	-1.27	12.5
28	5	3	1.64	7
29	5	3	-6.36	3
30	5	3	-0.91	25
31	5	3	7.27	12
35	5	3	2.36	12
36	5	3	9.27	11
39	5	3	9.09	11
40	5	3	5.64	15
46	5	3	-1.09	14
49	5	3	-1.64	15
55	5	3	1.82	
56	5	3	5.82	15
57	5	3	4.36	15
59	5	3	-5.09	40
63	5	3	2.55	15

66	5	3	2.18	16
67	5	3	5.45	30
68	5	3	9.09	10

2.56      15.16      MEAN  
 4.56      7.96      STDEVA  
 0.65      1.51      STEDV/SQRT(29)

**Supply**

Person	Round	CLIMPAQ	Accept.	Odor intensity
1	1	4	8.55	5
2	1	4	7.82	10
3	1	4	1.45	20
10	1	4	6.36	8
13	1	4	8.36	12
15	1	4	0.36	10
16	1	4	2.55	11
17	1	4	3.09	10
19	1	4	2.73	29
23	1	4	8.18	11
25	1	4	-1.27	12
28	1	4	7.27	5
29	1	4	9.09	10
30	1	4	0.73	18
31	1	4	6.00	11
35	1	4	9.09	10
36	1	4	9.27	10
39	1	4	9.27	15
40	1	4	8.55	10
46	1	4	6.18	5
49	1	4	0.73	15
55	1	4		
56	1	4	9.09	10
57	1	4		
59	1	4	0.00	12
63	1	4	9.09	12
66	1	4	6.36	12
67	1	4	9.09	15
68	1	4	8.91	11

5.81      11.81      MEAN  
 3.58      4.86      STDEVA  
 0.69      0.94      STEDV/SQRT(29)

1	2	4	8.55	8
2	2	4	5.09	10
3	2	4	0.36	10
10	2	4	7.27	7
13	2	4	9.09	15
15	2	4	0.91	10
16	2	4	3.09	11
17	2	4	7.82	8
19	2	4	2.91	25
23	2	4	6.91	12
25	2	4	-1.27	12
28	2	4	8.18	2
29	2	4	8.73	10
30	2	4	-0.91	25
31	2	4	7.27	10
35	2	4	9.64	10
36	2	4	9.09	10
39	2	4	8.36	12
40	2	4	8.36	12
46	2	4	5.82	5
49	2	4	6.00	15
55	2	4		
56	2	4	7.27	10
57	2	4		
59	2	4	0.91	12
63	2	4	8.55	11
66	2	4	6.36	13
67	2	4	8.18	15
68	2	4	8.18	11

			5.95	11.52	MEAN
			3.34	4.81	STDEVA
			0.64	0.93	STEDA/SQRT(29)
1	3	4	8.73	8	
2	3	4	8.18	10	
3	3	4	0.36	10	
10	3	4	7.64	8	
13	3	4	9.82	15	
15	3	4	2.18	10	
16	3	4	3.09	11	
17	3	4	0.55	11	
19	3	4	3.64	25	
23	3	4	7.45	12	
25	3	4	-0.55	10	
28	3	4	4.55	5	
29	3	4	8.73	15	
30	3	4	0.55	15	
31	3	4	7.82	11	
35	3	4	9.64	10	
36	3	4			
39	3	4	9.82	12	
40	3	4	7.64	12	
46	3	4	5.45	8	
49	3	4	6.00	10	
55	3	4			
56	3	4	0.36	20	
57	3	4			
59	3	4	0.00	12	
63	3	4	8.18	12	
66	3	4	7.64	11	
67	3	4	9.09	12	
68	3	4	-1.64	13	

5.19      11.85  
 3.82      3.93  
 0.75      0.77  
 MEAN  
 STDEVA  
 STEDA/SQRT(29)

1	4	4	6.36	15	
2	4	4	8.18	10	
3	4	4	0.55	10	
10	4	4	-4.55	9	
13	4	4	0.91	17	
15	4	4	9.09	10	
16	4	4	0.00	10	
17	4	4	1.45	10	
19	4	4	3.27	22	
23	4	4	6.91	17	
25	4	4	-0.18	10.8	
28	4	4	7.27	3	
29	4	4	8.73	10	
30	4	4	-1.82	30	
31	4	4	7.27	11	
35	4	4	9.64	10	
36	4	4	10.00	10	
39	4	4	9.09	11	
40	4	4	6.73	15	
46	4	4	7.64	5	
49	4	4	-0.36	15	
55	4	4			
56	4	4	1.82	25	
57	4	4			
59	4	4	-1.09	15	
63	4	4	8.55	11	
66	4	4	7.64	13	
67	4	4	8.73	20	
68	4	4	-1.09	11	

4.47      13.18  
 4.43      5.83  
 0.85      1.12  
 MEAN  
 STDEVA  
 STEDA/SQRT(29)

1	5	4	8.73	9	
2	5	4	8.18	15	

3	5	4	-0.73	30
10	5	4	-6.91	7
13	5	4	3.27	12
15	5	4	9.27	10
16	5	4	-1.45	13
17	5	4	1.82	11
19	5	4	3.64	22
23	5	4	6.91	16
25	5	4	-0.18	13.5
28	5	4	8.18	3
29	5	4	8.73	10
30	5	4	-2.18	28
31	5	4	8.73	11
35	5	4	6.36	10
36	5	4	9.45	12
39	5	4	10.00	11
40	5	4	8.18	13
46	5	4	7.64	5
49	5	4	2.91	10
55	5	4		
56	5	4	1.82	16
57	5	4		
59	5	4	-0.73	12
63	5	4	7.82	12
66	5	4	7.27	13
67	5	4	8.73	20
68	5	4	9.27	10

4.99 13.13

6.02

MEAN

STDEVA

0.89 1.16

STEDA/SQRT(29)

Round	Dilution Factor
1	1
2	2
3	6
4	9
5	16

CLIMPAQ	Material
1	Paint
2	Carpet
2	PVC
3	Supply

## Sensory test for real offices

Person	Office	Strategy	Acceptability	Odor intensity
1	1	1	-7.27	2
2	1	1	-5.09	30
3	1	1	2.00	10
4	1	1	-1.82	25
5	1	1	3.64	10
6	1	1	-4.36	50
7	1	1	0.55	15
9	1	1	-2.36	40
10	1	1	0.55	30
11	1	1	5.09	50
12	1	1	9.09	17
13	1	1	0.73	5
14	1	1	2.36	30
15	1	1	9.09	15
16	1	1	0.91	20
17	1	1	0.55	25
18	1	1	9.27	12
19	1	1	3.45	7.5
20	1	1	0.00	40
21	1	1	2.73	40
22	1	1	5.45	30
23	1	1	1.09	5
24	1	1	1.27	5
25	1	1	1.45	20
26	1	1	-0.73	4
27	1	1	4.36	20
28	1	1	5.09	20
29	1	1	0.55	18
30	1	1	-3.27	50
31	1	1	5.64	12
32	1	1	-1.82	6
33	1	1	2.73	12
34	1	1	-1.09	20
35	1	1	1.45	15
36	1	1	-1.45	12
			1.42	20.64
			3.82	13.81
			0.64	2.33
				MEAN
				STDEVA
				STEDA/SQRT(36)
1	2	2	-9.45	30
2	2	2	1.82	20
3	2	2	-1.45	20
4	2	2	0.36	20
5	2	2	8.18	12
6	2	2	0.91	15
7	2	2	5.45	15
9	2	2	6.36	15
10	2	2	5.82	20
11	2	2	-3.27	15
12	2	2	6.55	13
13	2	2	0.36	5
14	2	2	2.73	30
15	2	2	8.00	12
16	2	2	7.64	15
17	2	2	1.09	20
18	2	2	6.18	17
19	2	2	-0.55	15
20	2	2	6.91	20
21	2	2	6.55	20
22	2	2	-0.73	10
23	2	2	5.45	10
24	2	2	4.18	15
25	2	2	4.73	15
26	2	2	5.09	9
27	2	2	-0.55	6
28	2	2	8.73	10
29	2	2	0.55	20

30	2	2	-0.73	25
31	2	2	4.91	7
32	2	2	4.00	11
33	2	2	2.55	12
34	2	2	1.27	15
35	2	2	0.91	15
36	2	2	-2.18	12

2.81 15.46  
 3.95 5.84  
 0.66 0.99

MEAN  
 STDEVA  
 STEDA/SQRT(36)

1	3	2	-8.18	3
2	3	2	0.00	25
3	3	2	0.00	15
4	3	2	0.73	20
5	3	2	9.09	2
6	3	2	1.82	15
7	3	2	0.36	20
9	3	2	3.64	20
10	3	2	4.36	20
11	3	2	7.27	75
12	3	2	6.91	17
13	3	2	-1.64	4
14	3	2	7.27	15
15	3	2	2.18	22
16	3	2	6.18	20
17	3	2	1.45	20
18	3	2	9.45	11
19	3	2	1.09	7.5
20	3	2	3.09	20
21	3	2	5.45	25
22	3	2	-8.18	25
23	3	2	-1.27	7
24	3	2	4.73	15
25	3	2	2.73	15
26	3	2	5.09	9
27	3	2	0.55	10
28	3	2	2.55	30
29	3	2	-3.64	35
30	3	2	-1.27	30
31	3	2	2.91	10
32	3	2	5.64	9
33	3	2	0.00	20
34	3	2	0.00	20
35	3	2	1.82	15
36	3	2	-0.91	11

2.04 18.21  
 4.07 12.57  
 0.68 2.13

MEAN  
 STDEVA  
 STEDA/SQRT(36)

1	1	2	-2.55	35
2	1	2	-6.18	40
3	1	2	-7.64	40
4	1	2	-1.09	40
5	1	2	3.27	20
6	1	2	-0.73	35
7	1	2	0.73	15
8	1	2	-3.64	50
9	1	2	0.73	8
10	1	2	0.36	5
11	1	2	6	1.3
12	1	2	-3.27	20
13	1	2	0.73	25
14	1	2	0.36	15
15	1	2	1.27	17.5
16	1	2	4.73	20
17	1	2		
18	1	2		
19	1	2		
20	1	2		
21	1	2		



22	1	2		
23	1	2		
24	1	2		
25	1	2		
26	1	2		
27	1	2		
28	1	2		
29	1	2		

-0.432      24.175      MEAN  
 3.635      14.309      STDEVA  
 0.91      3.58      STEDA/SQRT(16)

1	2	1	-2.73	20
2	2	1	4.91	15
3	2	1	0.55	20
4	2	1	0.91	20
5	2	1	8.55	15
6	2	1	0.73	20
7	2	1	1.09	20
8	2	1	1.27	20
9	2	1	3.27	10
10	2	1	4.91	7
11	2	1	4.36	3
12	2	1	9.09	8
13	2	1	8	8
14	2	1	8.55	12
15	2	1	4.55	11
16	2	1	7.09	15
17	2	1	-0.73	20
18	2	1	0	10
19	2	1	1.45	12
20	2	1	0.55	8
21	2	1	6.36	15
22	2	1	-2	25
23	2	1	2.55	20
24	2	1	8.18	11
25	2	1	3.82	9
26	2	1	0	15
27	2	1	7.45	20
28	2	1	-4	20
29	2	1	7.82	15

3.33      14.62  
 3.78      5.47      MEAN  
 0.70      1.02      STDEVA  
                          STEDA/SQRT(29)

1	3	1	-4.73	25
2	3	1	2.18	17
3	3	1	5.09	20
4	3	1	-1.09	30
5	3	1	-1.27	30
6	3	1	2.91	15
7	3	1	3.45	15
8	3	1	0.36	25
9	3	1	3.64	8
10	3	1	9.09	9
11	3	1	8.18	1.5
12	3	1	5.09	9
13	3	1	3.09	19
14	3	1	8.18	13
15	3	1	4.18	12
16	3	1	6.55	15
17	3	1	-5.1	20
18	3	1	0	7
19	3	1	3.64	12
20	3	1	2.91	12
21	3	1	-2.18	15
22	3	1	-1.45	20
23	3	1	-1.45	25
24	3	1	3.64	12
25	3	1	4.55	8.5
26	3	1	-4.54	20

27	3	1	6.55	20	
28	3	1	0.91	15	
29	3	1	2.18	30	
			2.23	16.55	
			3.86	7.32	MEAN
			0.72	1.36	STDEVA
					STEDV/SQRT(29)

Office 1 MI  
Office 2 BE1  
Office 3 BE2

Strategy1 Continuous ventilation  
Strategy2 Intermittent ventilation

**DILUTION EXPERIMENT( SAMPLES OF ONE MATERIAL IN EACH TEST CHAMBER)**

Paint

Person	Round	Climpaq	Acceptability	Odor intensity
1	1	1	-0.73	40
2	1	1	5.45	30
3	1	1	8.36	12
4	1	1	5.45	12
5	1	1	5.45	10
6	1	1	7.27	15
7	1	1	6.73	15
8	1	1	-1.09	20
9	1	1	2.18	20
10	1	1	-7.45	12
11	1	1	0.55	10
12	1	1	2.36	15
13	1	1	-0.36	15
14	1	1	2.36	20
15	1	1	0.36	15
16	1	1	-0.73	15
17	1	1	3.27	5
18	1	1	1.82	15
19	1	1	9.64	9
20	1	1	5.45	12
21	1	1	4.73	12
22	1	1	2.55	10
23	1	1	0.91	15
24	1	1	9.64	10
25	1	1	0.91	9
26	1	1	1.82	20
27	1	1	-1.82	20
28	1	1	0.73	11
29	1	1	2.18	12
30	1	1	1.64	15
31	1	1	0.00	15
32	1	1	-2.91	13
33	1	1	-1.82	11
34	1	1	9.64	9
35	1	1	1.45	16
36	1	1	-1.82	17
37	1	1	-1.82	15
38	1	1	6.18	30
39	1	1	4.55	12

2.39 15.10  
 3.83 6.58  
 0.61 1.05

Mean  
 STDEVA  
 STDEVA/SQRT 39

1	2	1	5.27	20
2	2	1	9.09	15
3	2	1	5.82	14
4	2	1	8.91	15
5	2	1	7.27	5
6	2	1	9.09	10
7	2	1	7.64	12
8	2	1	-0.36	25
9	2	1	1.45	20
10	2	1	0.36	12
11	2	1	1.09	13
12	2	1	8.18	12
13	2	1	-1.27	25
14	2	1	-0.73	25
15	2	1	-3.64	18
16	2	1	-0.55	12
17	2	1	-1.64	15
18	2	1	3.27	15
19	2	1	-6.73	9
20	2	1	4.73	15
21	2	1	-3.27	20
22	2	1	2.18	10

23	2	1	3.09	8
24	2	1	4.55	15
25	2	1	0.73	9
26	2	1	0.55	15
27	2	1	8.73	13
28	2	1	-1.09	13
29	2	1	7.45	9
30	2	1	0.00	20
31	2	1	-3.64	20
32	2	1	-3.27	13
33	2	1	-3.09	12
34	2	1	0.73	11
35	2	1	0.55	17
36	2	1	-2.73	20
37	2	1	7.64	10
38	2	1	6.55	40
39	2	1	9.09	20

1.27 15.44  
 4.51 6.32  
 0.72 1.01

Mean  
 STDEVA  
 STDEVA/SQRT 39

1	3	1	-6.00	60
2	3	1	7.64	18
3	3	1	7.09	13
4	3	1	6.91	15
5	3	1	-1.27	20
6	3	1	5.09	18
7	3	1	2.73	11
8	3	1	-7.09	70
9	3	1	-2.91	20
10	3	1	1.09	14
11	3	1	9.45	15
12	3	1	7.27	12
13	3	1	-4.91	30
14	3	1	-1.82	30
15	3	1	0.36	17
16	3	1	2.55	5
17	3	1	-5.82	25
18	3	1	4.36	15
19	3	1	0.91	7
20	3	1	5.45	10
21	3	1	0.73	18
22	3	1	2.18	10
23	3	1	0.73	12
24	3	1	0.73	40
25	3	1	-4.00	12
26	3	1	-2.55	20
27	3	1	7.64	12
28	3	1	-1.82	11
29	3	1	0.91	10
30	3	1	0.91	15
31	3	1	-1.82	16
32	3	1	-2.91	12
33	3	1	-3.09	12
34	3	1	-0.91	12
35	3	1	-2.55	19
36	3	1	0.00	15
37	3	1	-2.18	35
38	3	1	6.00	45
39	3	1	5.27	25

0.88 19.90  
 4.31 13.72  
 0.69 2.20

Mean  
 STDEVA  
 STDEVA/SQRT 39

1	4	1	0.73	40
2	4	1	2.36	40
3	4	1	5.27	13
4	4	1	1.27	20
5	4	1	-1.09	20
6	4	1	-3.45	30
7	4	1	-6.55	20

8	4	1	-7.09	80
9	4	1	-1.82	20
10	4	1	-0.36	15
11	4	1	5.09	12
12	4	1	10.00	10
13	4	1	-5.82	35
14	4	1	-2.91	40
15	4	1	0.55	15
16	4	1	-0.36	11
17	4	1	-3.64	25
18	4	1	5.45	15
19	4	1	2.55	7
20	4	1	5.64	15
21	4	1	-4.73	25
22	4	1	-8.18	20
23	4	1	1.27	35
24	4	1	-4.18	80
25	4	1	-0.55	11
26	4	1	-3.27	40
27	4	1	5.45	12
28	4	1	-1.82	12
29	4	1	-0.55	11
30	4	1	-4.55	30
31	4	1	-2.73	24
32	4	1	-2.55	11
33	4	1	-2.55	11
34	4	1	-1.27	12
35	4	1	-3.27	18
36	4	1	-2.18	20
37	4	1	-8.73	60
38	4	1	7.64	20
39	4	1	-1.09	15

-0.82 24.36  
 4.34 17.38  
 0.69 2.78

Mean  
 STDEVA  
 STDEVA/SQRT 39

1	5	1	0.55	60
2	5	1	4.55	40
3	5	1	2.91	16
4	5	1	-5.45	40
5	5	1	-9.09	40
6	5	1	-4.73	30
7	5	1	-4.91	28
8	5	1	-8.36	90
9	5	1	2.91	15
10	5	1	-0.36	16
11	5	1	4.91	18
12	5	1	9.82	10
13	5	1	-9.27	40
14	5	1	-2.73	40
15	5	1	0.55	18
16	5	1	-0.55	11
17	5	1	-1.82	25
18	5	1	0.91	20
19	5	1	1.45	3
20	5	1	1.64	12
21	5	1	-8.00	28
22	5	1	8.55	20
23	5	1	-1.45	35
24	5	1	0.55	40
25	5	1	-0.55	11
26	5	1	7.27	15
27	5	1	8.18	7
28	5	1	-0.36	11
29	5	1	-0.91	13
30	5	1	-5.27	35
31	5	1	-1.27	15
32	5	1	-3.09	13
33	5	1	-2.55	11.5
34	5	1	-1.82	12

35	5	1	-4.73	20
36	5	1	-2.18	25
37	5	1	-9.09	75
38	5	1	-6.91	25
39	5	1	0.91	22

-1.07 25.88  
4.91 18.20  
0.79 2.91

Mean  
STDEVA  
STDEVA/SQRT 39

## Carpet

Person	Round	Climpeq	Acceptability	Odor intens.
1	1	2	-4	100
2	1	2	0.55	40
3	1	2	1.09	30
4	1	2	-1.27	25
5	1	2	-2.18	15
6	1	2	-4.18	45
7	1	2	-5.27	30
8	1	2	-5.45	50
9	1	2	-4.91	40
10	1	2	-0.73	15
11	1	2	-1.27	13
12	1	2	-8	30
13	1	2	-0.91	20
14	1	2	-5.64	50
15	1	2	-5.45	25
16	1	2	-2.36	20
17	1	2	-6.55	25
18	1	2	-4.55	30
19	1	2	-0.55	30
20	1	2	-2.91	25
21	1	2	0.73	15
22	1	2	2.18	15
23	1	2	0.73	15
24	1	2	-0.73	50
25	1	2	-0.91	11
26	1	2	-4	30
27	1	2	-2.73	18
28	1	2	-8.36	15
29	1	2	1.82	10
30	1	2	-3.62	25
31	1	2	-4.36	19
32	1	2	-2.73	13
33	1	2	-4.18	13
34	1	2	-1.45	14
35	1	2	-9.09	30
36	1	2	-6.18	20
37	1	2	-8.18	200
38	1	2	0.36	50
39	1	2	-3.27	35

-3.04 32.21  
2.95 32.28  
0.47 5.17

Mean  
STDEVA  
STDEVA/SQRT 39

1	2	2	2.55	50
2	2	2	2.36	40
3	2	2	5.82	18
4	2	2	-4.00	25
5	2	2	3.82	18
6	2	2	4.73	20
7	2	2	-2.00	20
8	2	2	-5.45	50
9	2	2	-2.55	20
10	2	2	-0.91	15
11	2	2	-2.55	20
12	2	2	-0.91	20
13	2	2	-3.64	30
14	2	2	0.73	30
15	2	2	-9.09	25
16	2	2	-0.91	13
17	2	2	-2.73	20

18	2	2	-6.73	30
19	2	2	-3.82	3
20	2	2	-7.27	30
21	2	2	-6.73	25
22	2	2	-8.18	20
23	2	2	0.73	15
24	2	2	-1.82	60
25	2	2	2.55	9.5
26	2	2	-1.45	30
27	2	2	-1.45	20
28	2	2	-1.64	12
29	2	2	2.91	10
30	2	2	-0.73	25
31	2	2	-6.00	25
32	2	2	-1.82	13
33	2	2	-6.18	14
34	2	2	-2.55	15
35	2	2	-2.55	20
36	2	2	-6.36	25
37	2	2	9.45	10
38	2	2	4.00	50
39	2	2	1.64	15

-1.51 23.35  
 4.15 12.37  
 0.66 1.98

Mean  
 STDEVA  
 STDEVA/SQRT 39

1	3	2	1.09	30
2	3	2	8.91	95
3	3	2	4	16
4	3	2	-2.36	25
5	3	2	1.09	15
6	3	2	7.64	15
7	3	2	-0.91	11
8	3	2	-7.45	80
9	3	2	-0.91	15
10	3	2	4.91	12
11	3	2	0.36	13
12	3	2	7.09	12
13	3	2	-5.82	31
14	3	2	2.36	25
15	3	2	0.55	17
16	3	2	-2	20
17	3	2	-4.91	25
18	3	2	1.45	20
19	3	2	-3.64	3
20	3	2	-0.91	18
21	3	2	-4	24
22	3	2	8.18	10
23	3	2	1.27	15
24	3	2	0.73	40
25	3	2	0.73	9
26	3	2	0.91	15
27	3	2	-1.27	15
28	3	2	0.36	10
29	3	2	1.27	10
30	3	2	-0.73	20
31	3	2	-1.82	17
32	3	2	-2.36	11
33	3	2	-2.91	11.5
34	3	2	4.18	8
35	3	2	-1.27	17
36	3	2	-4.91	20
37	3	2	8.55	10
38	3	2	5.82	35
39	3	2	1.64	15

0.64 20.78  
 4.05 17.57  
 0.65 2.81

Mean  
 STDEVA  
 STDEVA/SQRT 39

1	4	2	-5.09	20
2	4	2	3.27	35

3	4	2	6.36	14
4	4	2	2.55	20
5	4	2	-1.45	20
6	4	2	9.09	8
7	4	2	-3.45	17
8	4	2	-6.55	70
9	4	2	4.36	15
10	4	2	8.55	11
11	4	2	6	9
12	4	2	9.45	10
13	4	2	-5.27	36
14	4	2	2.18	30
15	4	2	2.18	15
16	4	2	-5.82	30
17	4	2	-5.27	20
18	4	2	2.18	20
19	4	2	1.64	8.5
20	4	2	-0.91	20
21	4	2	-7.27	28
22	4	2	2.18	20
23	4	2	0.36	20
24	4	2	1.45	30
25	4	2	3.27	10
26	4	2	0.73	20
27	4	2	-0.36	13
28	4	2	-0.36	10
29	4	2	-0.55	12
30	4	2	-6.00	35
31	4	2	-5.45	28
32	4	2	0.55	10
33	4	2	-2.73	11
34	4	2	2.18	12
35	4	2	1.09	15
36	4	2	-4.00	25
37	4	2	10.00	20
38	4	2	6.36	25
39	4	2	9.09	12

0.89 20.12  
 4.89 11.48  
 0.78 1.84

Mean  
 STDEVA  
 STDEVA/SQRT 39

1	5	2	9.45	10
2	5	2	3.09	30
3	5	2	1.27	20
4	5	2	3.82	20
5	5	2	7.27	25
6	5	2	2.00	20
7	5	2	-1.09	11
8	5	2	-4.55	70
9	5	2	-3.45	15
10	5	2	4.36	12
11	5	2	10.00	1
12	5	2	10.00	9
13	5	2	-8.18	38
14	5	2	2.55	28
15	5	2	8.73	11
16	5	2	1.09	9
17	5	2	-3.09	25
18	5	2	3.64	15
19	5	2	5.82	5
20	5	2	0.73	15
21	5	2	1.09	15
22	5	2	-7.27	10
23	5	2	0.91	10
24	5	2	5.09	10
25	5	2	1.45	9.5
26	5	2	7.82	15
27	5	2	10.00	8
28	5	2	-0.36	10
29	5	2	0.55	10



30	5	2	-5.27	35
31	5	2	1.45	8
32	5	2	-2.55	12
33	5	2	-1.45	10.5
34	5	2	8.00	9.5
35	5	2	-0.91	17
36	5	2	-3.64	28
37	5	2	8.36	9
38	5	2	8.18	25
39	5	2	0.73	18

2.20      16.88      Mean  
 4.98      12.08      STDEVA  
 0.80      1.94      STDEVA/SQRT 39

PVC

Person	Round	Climpaq	Acceptability	Odor intens.
1	1	3	8.55	20
2	1	3	0.73	40
3	1	3	8.36	12
4	1	3	4.18	15
5	1	3	1.09	15
6	1	3	-2.73	40
7	1	3	0.73	18
8	1	3	0	16
9	1	3	3.64	20
10	1	3	-8	11
11	1	3	7.64	9
12	1	3	9.27	12
13	1	3	0	13
14	1	3	-2.91	35
15	1	3	1.64	15
16	1	3	0.91	11
17	1	3	-2.73	20
18	1	3	3.09	15
19	1	3	9.64	9.5
20	1	3	4.55	12
21	1	3	-4.55	20
22	1	3	2.00	10
23	1	3	2.18	10
24	1	3	8.73	5
25	1	3	2.91	8
26	1	3	-0.91	15
27	1	3	8.73	15
28	1	3	-1.45	12
29	1	3	1.64	8
30	1	3	0.55	15
31	1	3	2.91	12
32	1	3	-1.45	12
33	1	3	-2.55	12
34	1	3	5.64	11
35	1	3	-4.55	22
36	1	3	0	15
37	1	3	8.18	12
38	1	3	5.82	25
39	1	3	2.91	30

2.16      16.09      Mean  
 4.37      8.15      STDEVA  
 0.70      1.31      STDEVA/SQRT 39

1	2	3	5.45	30
2	2	3	2.91	35
3	2	3	7.45	12
4	2	3	-5.64	30
5	2	3	8.18	5
6	2	3	6.36	15
7	2	3	-2.00	20
8	2	3	-7.45	70
9	2	3	5.45	15
10	2	3	-1.64	16
11	2	3	-6.36	26
12	2	3	-2.55	25

13	2	3	-2.91	28
14	2	3	-2.91	45
15	2	3	-7.64	25
16	2	3	0.55	9
17	2	3	-3.27	20
18	2	3	-6.73	30
19	2	3	0.91	4
20	2	3	-2.00	20
21	2	3	-1.09	20
22	2	3	-8.18	20
23	2	3	0.36	10
24	2	3	-0.36	50
25	2	3	-0.55	11
26	2	3	-9.45	70
27	2	3	0.91	20
28	2	3	0.73	14
29	2	3	-1.09	13
30	2	3	-4.36	30
31	2	3	-5.27	20
32	2	3	-2.18	12
33	2	3	-3.82	12
34	2	3	-4.36	20
35	2	3	-3.64	22
36	2	3	-5.09	20
37	2	3	2.91	15
38	2	3	4.00	50
39	2	3	-0.73	18

-1.41 23.77  
 4.41 15.22  
 0.71 2.44

Mean  
 STDEVA  
 STDEVA/SQRT 39

1	3	3	-2.55	20
2	3	3	7.27	25
3	3	3	6.36	14
4	3	3	9.45	10
5	3	3	5.45	15
6	3	3	3.45	20
7	3	3	5.09	9
8	3	3	-5.64	40
9	3	3	-2.36	20
10	3	3	4.55	11
11	3	3	8.91	10
12	3	3	8.18	11
13	3	3	-6.73	32
14	3	3	4.73	20
15	3	3	6.55	14
16	3	3	2.73	5
17	3	3	-2.36	15
18	3	3	1.82	20
19	3	3	6.73	7
20	3	3	5.27	12
21	3	3	-5.45	28
22	3	3	8.18	10
23	3	3	0.91	12
24	3	3	8.73	10
25	3	3	1.09	9.5
26	3	3	0.91	20
27	3	3	-0.91	25
28	3	3	-0.36	10
29	3	3	1.27	9
30	3	3	-8.00	40
31	3	3	-1.27	12
32	3	3	-2.91	11
33	3	3	-4.91	12
34	3	3	8.73	9
35	3	3	0.55	16
36	3	3	-1.82	16
37	3	3	8.55	9
38	3	3	8.55	25
39	3	3	5.82	15

			2.42	16.12	Mean
			5.05	8.37	STDEVA
			0.81	1.34	STDEVA/SQRT 39
1	4	3	4.18	30	
2	4	3	2.73	30	
3	4	3	-0.91	30	
4	4	3	-1.27	30	
5	4	3	7.27	15	
6	4	3	2.55	25	
7	4	3	-7.64	22	
8	4	3	-6.55	60	
9	4	3	1.09	25	
10	4	3	5.09	11	
11	4	3	2.00	17	
12	4	3	9.09	10	
13	4	3	-4.36	33	
14	4	3	-1.09	35	
15	4	3	3.64	15	
16	4	3	3.82	5	
17	4	3	-7.27	20	
18	4	3	0.55	25	
19	4	3	1.64	9	
20	4	3	3.27	18	
21	4	3	-8.55	28	
22	4	3	-8.36	20	
23	4	3	-0.55	12	
24	4	3	-2.91	70	
25	4	3	0.55	11	
26	4	3	-6.55	50	
27	4	3	-0.18	15	
28	4	3	0.73	12	
29	4	3	-8.36	15	
30	4	3	-6.36	40	
31	4	3	-0.91	12	
32	4	3	-3.27	11	
33	4	3	-3.64	12	
34	4	3	-0.55	11	
35	4	3	0.55	17	
36	4	3	-1.64	20	
37	4	3	1.64	15	
38	4	3	7.09	20	
39	4	3	-2.73	20	
			-0.67	22.46	Mean
			4.57	13.84	STDEVA
			0.73	2.22	STDEVA/SQRT 39
1	5	3	0.55	30	
2	5	3	1.09	25	
3	5	3	4.00	16	
4	5	3	-1.27	30	
5	5	3	-7.82	30	
6	5	3	5.09	15	
7	5	3	-0.73	11	
8	5	3	-5.09	70	
9	5	3	7.45	12	
10	5	3	5.45	13	
11	5	3	6.00	3	
12	5	3	10.00	9	
13	5	3	-8.55	37	
14	5	3	6.18	18	
15	5	3	8.18	13	
16	5	3	-4.91	20	
17	5	3	-2.73	20	
18	5	3	3.82	15	
19	5	3	-6.55	8	
20	5	3	0.73	15	
21	5	3	0.91	15	
22	5	3	-9.09	20	
23	5	3	0.91	15	
24	5	3	2.55	40	

25	5	3	2.00	10.5
26	5	3	8.18	10
27	5	3	9.64	12
28	5	3	-1.45	16
29	5	3	0.55	10
30	5	3	-5.09	35
31	5	3	-1.82	16
32	5	3	-2.18	11
33	5	3	-3.64	12.5
34	5	3	6.73	9
35	5	3	-3.09	18
36	5	3	-2.36	20
37	5	3	8.91	9
38	5	3	7.82	20
39	5	3	-1.64	22

0.99 18.74

5.36 11.91

0.86 1.91

Mean  
STDEVA  
STDEVA/SQRT 39

Supply

Person	Round	Climpaq	Acceptability	Odor intens.
1	1	4	2	20
2	1	4	6.36	20
3	1	4	5.82	14
4	1	4	-6.36	30
5	1	4	-5.45	25
6	1	4	-1.09	40
7	1	4	-2.73	25
8	1	4	0.36	16
9	1	4	2	20
10	1	4	8.18	10
11	1	4	10	7
12	1	4	7.09	11
13	1	4	0	14
14	1	4	-2.91	30
15	1	4	0.55	15
16	1	4	-4.55	25
17	1	4	-1.64	15
18	1	4	7.09	20
19	1	4	9.27	8
20	1	4	1.45	15
21	1	4	-6.36	25
22	1	4	-2.55	10
23	1	4	-3.82	45
24	1	4	2.18	30
25	1	4	9.09	10
26	1	4	9.45	10
27	1	4	2.18	5
28	1	4	0	11
29	1	4	2	8
30	1	4	-1.45	20
31	1	4	1.82	14
32	1	4	1.45	11
33	1	4	-4	15
34	1	4	9.45	9.5
35	1	4	-0.73	19
36	1	4	4.55	13
37	1	4	1.27	8
38	1	4	8	15
39	1	4	2.18	20

1.80 17.40

4.80 8.94

0.77 1.43

Mean  
STDEVA  
STDEVA/SQRT 39

1	2	4	3.64	20
2	2	4	5.45	25
3	2	4	6.00	17
4	2	4	5.45	15
5	2	4	9.09	5
6	2	4	7.27	10
7	2	4	-1.27	12

8	2	4	-7.45	70
9	2	4	-4.73	30
10	2	4	7.27	10
11	2	4	7.64	6
12	2	4	4.55	11
13	2	4	-2.36	26
14	2	4	2.73	25
15	2	4	1.09	15
16	2	4	-2.36	15
17	2	4	-1.82	15
18	2	4	1.45	15
19	2	4	-1.09	6
20	2	4	4.55	14
21	2	4	1.45	15
22	2	4	-2.91	10
23	2	4	-0.91	35
24	2	4	3.27	30
25	2	4	7.27	10
26	2	4	7.45	10
27	2	4	7.27	13
28	2	4	6.00	10
29	2	4	-0.36	11
30	2	4	-4.36	30
31	2	4	-4.91	28
32	2	4	-1.27	11
33	2	4	-2.73	12
34	2	4	8.36	10
35	2	4	0.55	16
36	2	4	-6.55	30
37	2	4	6.00	12
38	2	4	7.27	15
39	2	4	2.73	10

2.02 17.44  
 4.66 11.65  
 0.75 1.87

Mean  
 STDEVA  
 STDEVA/SQRT 39

1	3	4	2.36	30
2	3	4	4.91	20
3	3	4	5.45	14
4	3	4	-4.73	35
5	3	4	-6.36	25
6	3	4	-2.00	40
7	3	4	1.82	11
8	3	4	-6.91	40
9	3	4	3.64	15
10	3	4	9.27	10
11	3	4	10	10
12	3	4	7.64	11
13	3	4	-1.27	26
14	3	4	5.82	25
15	3	4	6.36	12
16	3	4	-5.45	20
17	3	4	-3.82	20
18	3	4	3.64	20
19	3	4	4	4
20	3	4	1.27	15
21	3	4	-5.45	30
22	3	4	8.36	10
23	3	4	0.73	12
24	3	4	1.64	30
25	3	4	-0.36	11
26	3	4	8.55	10
27	3	4	10	5
28	3	4	0	10
29	3	4	-0.73	11
30	3	4	-6.36	30
31	3	4	-6	27
32	3	4	-2	12
33	3	4	-2.55	11.5
34	3	4	9.27	9.5

35	3	4	0.91	15
36	3	4	-6.36	30
37	3	4	8.73	10
38	3	4	9.45	15
39	3	4	3.09	15

1.71 18.13  
 5.47 9.55  
 0.88 1.53

Mean  
 STDEVA  
 STDEVA/SQRT 39

1	4	4	0.73	30
2	4	4	7.45	20
3	4	4	4.55	16
4	4	4	-6.73	40
5	4	4	8.73	12
6	4	4	5.09	20
7	4	4	-1.64	13
8	4	4	-7.64	40
9	4	4	7.27	12
10	4	4	9.45	10
11	4	4	10.00	2
12	4	4	10.00	10
13	4	4	-5.45	34
14	4	4	0.91	30
15	4	4	-0.73	18
16	4	4	2.18	8
17	4	4	-6.18	25
18	4	4	4.36	15
19	4	4	-1.27	2
20	4	4	-0.73	15
21	4	4	-8.36	28
22	4	4	-2.91	20
23	4	4	0.73	25
24	4	4	0.36	20
25	4	4	3.64	10.5
26	4	4	8.73	10
27	4	4	7.64	12
28	4	4	1.45	10
29	4	4	-1.09	13
30	4	4	-7.82	40
31	4	4	-7.27	32
32	4	4	0.91	10
33	4	4	-2.00	11
34	4	4	9.64	10
35	4	4	-0.36	19
36	4	4	0.00	15
37	4	4	8.36	10
38	4	4	9.09	12
39	4	4	7.27	15

1.75 17.81  
 5.74 10.01  
 0.92 1.60

Mean  
 STDEVA  
 STDEVA/SQRT 39

1	5	4	2.00	30
2	5	4	6.18	20
3	5	4	3.09	16
4	5	4	-5.45	40
5	5	4	-8.18	40
6	5	4	8.00	15
7	5	4	-2.91	13
8	5	4	-7.64	50
9	5	4	3.64	15
10	5	4	10.00	10
11	5	4	6.36	4
12	5	4	10.00	9
13	5	4	-9.09	40
14	5	4	5.09	23
15	5	4	9.64	12
16	5	4	2.91	7
17	5	4	-4.36	25
18	5	4	3.27	15
19	5	4	9.09	2

20	5	4	1.27	14
21	5	4	3.27	12
22	5	4	-8.18	20
23	5	4	-1.09	35
24	5	4	-0.55	40
25	5	4	1.45	11
26	5	4	9.27	10
27	5	4	10.00	5
28	5	4	0.73	10
29	5	4	0.73	10
30	5	4	-6.18	40
31	5	4	-5.45	2
32	5	4	0.91	10
33	5	4	-3.27	11.5
34	5	4	9.82	9
35	5	4	0.91	16
36	5	4	-0.91	12
37	5	4	3.45	16
38	5	4	9.82	12
39	5	4	1.64	21
			1.78	18.01
			5.83	12.32
			0.93	1.97

Mean  
STDEVA  
STDEVA/SQRT 39

39	1	3	1	-1.82	1
38	3	3	1	4.56	1
37	3	3	1	-1.09	1
36	3	3	1	2.36	1
35	3	3	1	4.36	1
34	3	3	1	7.64	1
33	3	3	1	-2.91	1
32	3	3	1	4.56	1
31	3	3	1	4.36	1
30	3	3	1	8.36	1
29	3	3	1	0.91	1
28	3	3	1	9.64	1
27	3	3	1	0.91	1
26	3	3	1	8.36	1
25	3	3	1	4.36	1
24	3	3	1	4.56	1
23	3	3	1	-2.91	1
22	3	3	1	7.64	1
21	3	3	1	4.36	1
20	3	3	1	4.36	1
19	3	3	1	8.36	1
18	3	3	1	0.91	1
17	3	3	1	9.64	1
16	3	3	1	0.91	1
15	3	3	1	8.36	1
14	3	3	1	4.36	1
13	3	3	1	4.56	1
12	3	3	1	-2.91	1
11	3	3	1	7.64	1
10	3	3	1	4.36	1
9	3	3	1	4.36	1
8	3	3	1	8.36	1
7	3	3	1	0.91	1
6	3	3	1	9.64	1
5	3	3	1	0.91	1
4	3	3	1	8.36	1
3	3	3	1	4.36	1
2	3	3	1	4.56	1
1	3	3	1	-1.82	1

Mean 16.09  
STDEVA 7.84  
STDEVA/SQRT 34 1.34

39	2	2	1	5.08	1
38	2	2	1	2.36	1
37	2	2	1	-7.45	1
36	2	2	1	-3.82	1
35	2	2	1	3.27	1
34	2	2	1	0.91	1
33	2	2	1	4.36	1
32	2	2	1	-2.91	1
31	2	2	1	9.64	1
30	2	2	1	0.91	1
29	2	2	1	8.36	1
28	2	2	1	4.36	1
27	2	2	1	4.56	1
26	2	2	1	-2.91	1
25	2	2	1	7.64	1
24	2	2	1	4.36	1
23	2	2	1	4.36	1
22	2	2	1	8.36	1
21	2	2	1	0.91	1
20	2	2	1	9.64	1
19	2	2	1	0.91	1
18	2	2	1	8.36	1
17	2	2	1	4.36	1
16	2	2	1	4.56	1
15	2	2	1	-2.91	1
14	2	2	1	7.64	1
13	2	2	1	4.36	1
12	2	2	1	4.36	1
11	2	2	1	8.36	1
10	2	2	1	0.91	1
9	2	2	1	9.64	1
8	2	2	1	0.91	1
7	2	2	1	8.36	1
6	2	2	1	4.36	1
5	2	2	1	4.56	1
4	2	2	1	-2.91	1
3	2	2	1	7.64	1
2	2	2	1	4.36	1
1	2	2	1	4.36	1



			1.58	19.60	Mean
			4.60	13.17	STDEVA
			0.79	2.26	STDEVA/SQRT 34
1	4	1	-0.55	30	
2	4	1	-7.27	50	
3	4	1	1.09	17	
4	4	1	-6.55	40	
5	4	1	0.91	20	
6	4	1	-8.73	48	
7	4	1	-8.08	50	
8	4	1	0.36	20	
9	4	1	1.82	15	
10	4	1	4.00	12	
12	4	1	5.82	12	
13	4	1	-0.18	13	
14	4	1	-5.27	55	
15	4	1	1.27	19	
16	4	1	4.91	5	
17	4	1	-0.55	15	
18	4	1	1.82	30	
20	4	1	6.00	30	
21	4	1	-2.36	22	
22	4	1	-8.55	20	
23	4	1	-0.73	10	
26	4	1	-2.18	20	
27	4	1	8.18	15	
28	4	1	-1.27	11	
29	4	1	0.91	10	
30	4	1	-7.27	30	
31	4	1	-6.36	28	
32	4	1	-2.73	13	
33	4	1	-0.73	10.5	
34	4	1	8.18	11	
35	4	1	-0.91	13	
37	4	1	4.55	20	
38	4	1	7.45	30	
39	4	1	-8.73	18	

-0.67 22.43  
 5.11 13.05  
 0.88 2.24

Mean  
 STDEVA  
 STDEVA/SQRT 34

1	5	1	2.73	18
2	5	1	6.18	18
3	5	1	4.00	18
4	5	1	4.55	18
5	5	1	-3.27	38
6	5	1	6.55	18
7	5	1	-3.82	35
8	5	1	1.27	28
9	5	1	3.82	33
10	5	1	7.64	14
12	5	1	7.27	11
13	5	1	-6.18	36
14	5	1	-2.18	43
15	5	1	6.36	15
16	5	1	-3.64	18
17	5	1	-3.27	28
18	5	1	3.45	15
20	5	1	-0.73	23
21	5	1	8.18	15
22	5	1	0.00	13
23	5	1	0.36	13
26	5	1	3.82	13
27	5	1	6.36	15
28	5	1	0.73	13
29	5	1	0.36	13
30	5	1	0.55	18
31	5	1	-3.64	21
32	5	1	-2.18	15
33	5	1	-2.00	13.5

34	5	1	4.36	16
35	5	1	-0.91	18
37	5	1	3.64	18
38	5	1	3.64	33
39	5	1	-0.91	22

1.58      20.49  
 3.92      8.51  
 0.67      1.46

Mean  
 STDEVA  
 STDEVA/SQRT 34

Paint & Vinyl

Person	Round	Climpeg	Acceptability	Odor intensity
1	1	2	2.36	20
2	1	2	0.73	30
3	1	2	7.09	14
4	1	2	-2.55	30
5	1	2	-1.27	25
6	1	2	-3.82	30
7	1	2	-6.36	38
8	1	2	-6.00	60
9	1	2	-2.36	70
10	1	2	0.36	12
12	1	2	9.09	11
13	1	2	-0.55	22
14	1	2	-3.82	50
15	1	2	-0.36	20
16	1	2	2.91	5
17	1	2	-3.09	20
18	1	2	2.36	20
20	1	2	1.09	15
21	1	2	1.82	18
22	1	2	2.91	10
23	1	2	-1.09	20
26	1	2	-1.82	15
27	1	2	2.00	15
28	1	2	-0.36	12
29	1	2	0.73	9
30	1	2	0.55	15
31	1	2	-4.55	20
32	1	2	-3.27	13
33	1	2	-1.82	11
34	1	2	-2.73	18
35	1	2	-5.09	24
37	1	2	-9.09	60
38	1	2	5.82	35
39	1	2	-8.36	25

-0.84      23.88  
 4.03      15.51  
 0.69      2.66

Mean  
 STDEVA  
 STDEVA/SQRT 34

1	2	2	5.27	15
2	2	2	6.73	15
3	2	2	3.45	14
4	2	2	-3.27	30
5	2	2	-8.73	45
6	2	2	-1.82	20
7	2	2	-6.91	35
8	2	2	-2.91	50
9	2	2	-2.18	60
10	2	2	0.55	13
12	2	2	9.64	10
13	2	2	-0.55	20
14	2	2	-3.82	45
15	2	2	-2.36	27
16	2	2	2.36	8
17	2	2	-1.64	15
18	2	2	2.36	20
20	2	2	0.91	15
21	2	2	4.55	15
22	2	2	2.00	10
23	2	2	-0.36	10
26	2	2	-3.27	20

27	2	2	3.08	12
28	2	2	-1.27	12
29	2	2	-0.36	10
30	2	2	-3.08	20
31	2	2	-0.73	8
32	2	2	-4.73	14
33	2	2	-2.36	11.5
34	2	2	8.91	11
35	2	2	-3.27	14
37	2	2	-5.64	60
38	2	2	8.91	15
39	2	2	2.18	20

0.05 21.16  
 4.46 14.52  
 0.76 2.49

Mean  
 STDEVA  
 STDEVA/SQRT 34

1	3	2	-1.64	40
2	3	2	-1.27	35
3	3	2	8.73	11
4	3	2	0.73	25
5	3	2	-8.18	35
6	3	2	-2.55	15
7	3	2	-4.36	30
8	3	2	-4.55	40
9	3	2	-5.08	50
10	3	2	3.82	13
12	3	2	9.64	10
13	3	2	-0.91	18
14	3	2	-2.36	35
15	3	2	9.82	12
16	3	2	4.73	5
17	3	2	-1.64	20
18	3	2	4.73	20
20	3	2	-0.55	18
21	3	2	4.00	15
22	3	2	4.00	20
23	3	2	0.36	10
26	3	2	6.91	15
27	3	2	8.00	12
28	3	2	0.00	10
29	3	2	0.55	10
30	3	2	-0.18	15
31	3	2	-3.64	16
32	3	2	-1.82	11
33	3	2	-1.45	11
34	3	2	7.64	11
35	3	2	-2.00	13
37	3	2	-8.18	60
38	3	2	7.08	35
39	3	2	0.91	18

0.92 21  
 4.90 13.02  
 0.84 2.23

Mean  
 STDEVA  
 STDEVA/SQRT 34

1	4	2	0.91	20
2	4	2	1.08	25
3	4	2	7.08	13
4	4	2	-4.91	40
5	4	2	3.27	20
6	4	2	4.36	12
7	4	2	-3.27	35
8	4	2	-0.55	25
9	4	2	0.36	20
10	4	2	5.27	13
12	4	2	9.64	10
13	4	2	-3.27	32
14	4	2	-4.73	40
15	4	2	9.27	12
16	4	2	0.91	9
17	4	2	-5.08	25
18	4	2	2.91	20

20	4	2	-0.36	15
21	4	2	1.45	18
22	4	2	2.18	10
23	4	2	-0.73	10
26	4	2	0.91	15
27	4	2	8.91	12
28	4	2	-0.91	10
29	4	2	-0.36	11
30	4	2	-4.18	25
31	4	2	-1.27	12
32	4	2	-3.09	13
33	4	2	-1.82	11
34	4	2	8.55	11
35	4	2	-3.64	25
37	4	2	8.55	10
38	4	2	8.18	25
39	4	2	1.45	16

1.39 18.24  
 4.53 8.79  
 0.78 1.51

Mean  
 STDEVA  
 STDEVA/SQRT 34

1	5	2	0.91	20
2	5	2	3.82	25
3	5	2	7.82	13
4	5	2	3.45	25
5	5	2	3.45	20
6	5	2	6.36	12
7	5	2	-2.73	28
8	5	2	-1.09	25
9	5	2	-2.55	30
10	5	2	8.55	11
12	5	2	9.64	10
13	5	2	-5.82	34
14	5	2	-4.55	50
15	5	2	2.36	15
16	5	2	4.36	5
17	5	2	-5.27	30
18	5	2	4.00	15
20	5	2	-4.00	20
21	5	2	2.91	18
22	5	2	1.64	10
23	5	2	0.73	10
26	5	2	1.27	15
27	5	2	9.82	13
28	5	2	2.91	9
29	5	2	0.36	10
30	5	2	3.82	12
31	5	2	-4.55	21
32	5	2	-2.91	12
33	5	2	-1.82	11
34	5	2	9.09	11
35	5	2	-0.91	12
37	5	2	7.45	15
38	5	2	7.64	25
39	5	2	0.91	15

1.97 17.85  
 4.58 9.17  
 0.79 1.57

Mean  
 STDEVA  
 STDEVA/SQRT 34

Paint & carpet

Person	Round	Climpaq	Acceptability	Odor intensity
1	1	3	5.27	20
2	1	3	-5.45	60
3	1	3	1.82	18
4	1	3	-2.73	30
5	1	3	-3.64	25
6	1	3	-1.09	28
7	1	3	-7.64	38
8	1	3	-6.36	70
9	1	3	-2.55	60
10	1	3	0.91	13

12	1	3	1.82	15
13	1	3	-1.45	25
14	1	3	2.73	25
15	1	3	0.73	15
16	1	3	-3.09	20
17	1	3	-2.00	20
18	1	3	2.18	20
20	1	3	-4.55	30
21	1	3	-4.73	26
22	1	3	-10.00	20
23	1	3	-1.27	20
26	1	3	0.55	15
27	1	3	5.09	17
28	1	3	1.09	10
29	1	3	1.09	10
30	1	3	2.55	12
31	1	3	-2.73	17
32	1	3	-2.00	12
33	1	3	-1.82	11
34	1	3	-1.45	15
35	1	3	-6.55	26
37	1	3	-8.18	50
38	1	3	5.82	40
39	1	3	-8.91	20

-1.66 25.09  
 4.07 15.01  
 0.70 2.57

Mean  
 STDEVA  
 STDEVA/SQRT 34

1	2	3	0.36	30
2	2	3	6.91	20
3	2	3	0.55	19
4	2	3	-3.82	35
5	2	3	-8.55	45
6	2	3	1.82	18
7	2	3	-6.73	40
8	2	3	-1.45	35
9	2	3	0.73	30
10	2	3	1.27	13
12	2	3	9.09	10
13	2	3	-0.73	23
14	2	3	0.73	35
15	2	3	5.45	15
16	2	3	2.91	7
17	2	3	-0.55	15
18	2	3	1.09	20
20	2	3	-2.73	20
21	2	3	8.18	12
22	2	3	-8.55	20
23	2	3	0.55	5
26	2	3	1.45	15
27	2	3	5.82	12
28	2	3	0.00	11
29	2	3	-0.36	11
30	2	3	-2.36	20
31	2	3	-4.55	20
32	2	3	-2.91	13
33	2	3	-0.91	10.5
34	2	3	8.36	11
35	2	3	-2.00	13
37	2	3	8.36	10
38	2	3	8.18	20
39	2	3	5.09	16

0.90 19.10  
 4.74 9.82  
 0.81 1.68

Mean  
 STDEVA  
 STDEVA/SQRT 34

1	3	3	0.55	20
2	3	3	0.91	30
3	3	3	7.64	11
4	3	3	-1.27	30
5	3	3	-7.45	35

6	3	3	4.00	10
7	3	3	-1.82	25
8	3	3	-7.27	40
9	3	3	4.55	20
10	3	3	9.09	11
12	3	3	9.45	8
13	3	3	-3.09	28
14	3	3	3.27	20
15	3	3	4.73	13
16	3	3	2.55	8
17	3	3	-4.18	25
18	3	3	4.00	15
20	3	3	-2.73	20
21	3	3	7.82	12
22	3	3	3.09	10
23	3	3	-0.73	20
26	3	3	2.73	15
27	3	3	6.55	15
28	3	3	0.73	9
29	3	3	-0.73	12
30	3	3	-5.45	25
31	3	3	-2.00	14
32	3	3	-2.91	13
33	3	3	-1.82	11
34	3	3	7.64	11
35	3	3	-0.91	12
37	3	3	3.82	25
38	3	3	8.55	25
39	3	3	3.45	16

1.55 18.06  
 4.66 8.23  
 0.80 1.41

Mean  
 STDEVA  
 STDEVA/SQRT 34

1	4	3	2.73	20
2	4	3	0.73	30
3	4	3	6.55	13
4	4	3	-5.82	30
5	4	3	0.91	25
6	4	3	5.45	12
7	4	3	-3.64	31
8	4	3	-3.09	35
9	4	3	5.27	15
10	4	3	3.45	12
12	4	3	9.45	10
13	4	3	-5.09	30
14	4	3	-4.36	45
15	4	3	-0.91	20
16	4	3	-1.09	11
17	4	3	-4.91	25
18	4	3	0.55	25
20	4	3	-0.73	15
21	4	3	-3.64	24
22	4	3	2.00	10
23	4	3	-0.55	10
26	4	3	-2.00	20
27	4	3	8.36	13
28	4	3	1.09	10
29	4	3	0.55	10
30	4	3	-2.73	20
31	4	3	-5.09	25
32	4	3	-2.00	11
33	4	3	-1.82	11
34	4	3	9.09	11
35	4	3	-2.73	14
37	4	3	8.00	10
38	4	3	7.27	30
39	4	3	-1.45	18

0.58 19.15  
 4.51 9.05  
 0.77 1.55

Mean  
 STDEVA  
 STDEVA/SQRT 34

1	5	3	-2.73	40
2	5	3	-2.00	40
3	5	3	0.36	19
4	5	3	2.18	25
5	5	3	1.09	15
6	5	3	-3.45	35
7	5	3	-6.36	35
8	5	3	-2.73	45
9	5	3	-2.91	40
10	5	3	1.64	15
12	5	3	8.18	12
13	5	3	-8.55	38
14	5	3	-3.82	45
15	5	3	-0.73	25
16	5	3	-0.55	11
17	5	3	-6.55	30
18	5	3	0.73	25
20	5	3	-3.82	30
21	5	3	1.64	18
22	5	3	-10.00	20
23	5	3	1.09	15
26	5	3	-2.55	30
27	5	3	8.36	15
28	5	3	-2.00	12
29	5	3	-0.36	11
30	5	3	-3.64	25
31	5	3	-3.27	15
32	5	3	-2.73	14
33	5	3	-2.73	11.5
34	5	3	5.64	13
35	5	3	-3.64	15
37	5	3	-8.00	40
38	5	3	6.73	40
39	5	3	-9.45	25

-1.61 24.78  
 4.54 11.29  
 0.78 1.94

Mean  
 STDEVA  
 STDEVA/SQRT 34

Supply

Person	Round	Climpaq	Acceptability	Odor intensity
1	1	4	7.45	10
2	1	4	0.73	30
3	1	4	2.36	17
4	1	4	-0.73	25
5	1	4	-5.45	28
6	1	4	3.64	15
7	1	4	-6.73	37
8	1	4	-3.82	50
9	1	4	-1.45	50
10	1	4	9.45	10
12	1	4	10.00	10
13	1	4	-0.91	25
14	1	4	1.27	35
15	1	4	9.82	10
16	1	4	0.36	9
17	1	4	-5.45	20
18	1	4	3.27	15
20	1	4	-0.91	20
21	1	4	6.73	12
22	1	4	-9.09	20
23	1	4	-0.73	20
26	1	4	8.18	10
27	1	4	6.91	8
28	1	4	4.36	9
29	1	4	0.73	9
30	1	4	0.00	17
31	1	4	-1.45	12
32	1	4	-3.64	14
33	1	4	-0.91	10
34	1	4	8.64	10

35	1	4	-0.73	17
37	1	4	8.18	8
38	1	4	7.27	20
39	1	4	-1.64	25

1.67 18.74  
5.21 11.13  
0.69 1.91

Mean  
STDEVA  
STDEVA/SQRT 34

1	2	4	8	10
2	2	4	-0.55	40
3	2	4	4.18	16
4	2	4	-7.27	45
5	2	4	-6.55	40
6	2	4	8.18	8
7	2	4	-8.18	40
8	2	4	-5.09	65
9	2	4	-2.18	60
10	2	4	9.09	10
12	2	4	10	10
13	2	4	-3.64	30
14	2	4	2.91	27
15	2	4	9.45	12
16	2	4	-4.91	20
17	2	4	-2	25
18	2	4	4	15
20	2	4	1.82	12
21	2	4	4.55	15
22	2	4	-8.09	20
23	2	4	0.36	5
26	2	4	8.18	10
27	2	4	10	7
28	2	4	-0.73	10
29	2	4	0.55	10
30	2	4	-5.45	25
31	2	4	-5.45	20
32	2	4	-2.55	11
33	2	4	-1.27	11
34	2	4	9.64	10
35	2	4	-1.82	13
37	2	4	9.09	8
38	2	4	8.73	10
39	2	4	2.55	16

1.31 20.18  
6.09 15.13  
1.04 2.59

Mean  
STDEVA  
STDEVA/SQRT 34

1	3	4	3.27	20
2	3	4	-6.36	50
3	3	4	6.55	14
4	3	4	-5.64	40
5	3	4	-7.64	35
6	3	4	8.73	6
7	3	4	-7.45	41
8	3	4	-4.91	60
9	3	4	-0.55	40
10	3	4	9.27	10
12	3	4	10.00	10
13	3	4	-2.55	28
14	3	4	-1.27	35
15	3	4	9.64	12
16	3	4	5.27	5
17	3	4	-3.64	25
18	3	4	1.82	15
20	3	4	0.36	15
21	3	4	2.73	18
22	3	4	2.36	10
23	3	4	0.36	5
26	3	4	8.18	10
27	3	4	10.00	7
28	3	4	3.64	10
29	3	4	-0.55	11



30	3	4	-5.09	25
31	3	4	-5.45	32
32	3	4	-2.18	12
33	3	4	-1.82	11.5
34	3	4	9.64	10
35	3	4	0.91	10
37	3	4	1.82	25
38	3	4	9.09	15
39	3	4	7.45	14

1.65 20.19  
 5.70 13.95  
 0.98 2.39

Mean  
 STDEVA  
 STDEVA/SQRT 34

1	4	4	4.55	25
2	4	4	-1.45	50
3	4	4	5.82	14
4	4	4	-5.45	50
5	4	4	-3.64	35
6	4	4	5.45	12
7	4	4	-4.55	32
8	4	4	1.82	15
9	4	4	-4.55	40
10	4	4	9.45	11
12	4	4	10.00	10
13	4	4	-2.55	25
14	4	4	1.27	30
15	4	4	3.62	15
16	4	4	-2.73	13
17	4	4	-4.00	25
18	4	4	1.45	20
20	4	4	0.55	15
21	4	4	-1.45	22
22	4	4	2.18	10
23	4	4	1.82	15
26	4	4	-0.91	15
27	4	4	10.00	7
28	4	4	2.73	10
29	4	4	0.55	10
30	4	4	-3.64	25
31	4	4	-5.45	38
32	4	4	-1.82	11
33	4	4	-1.82	11.5
34	4	4	9.45	10
35	4	4	-0.36	12
37	4	4	9.09	8
38	4	4	8.36	20
39	4	4	-1.09	16

1.25 19.83  
 4.83 11.67  
 0.83 2.00

Mean  
 STDEVA  
 STDEVA/SQRT 34

1	5	4	0.91	30
2	5	4	1.27	35
3	5	4	8.91	12
4	5	4	-2.36	35
5	5	4	0.91	20
6	5	4	5.09	20
7	5	4	-2.91	25
8	5	4	-0.18	35
9	5	4	-2.00	40
10	5	4	9.64	10
12	5	4	10.00	10
13	5	4	-3.45	28
14	5	4	-0.55	35
15	5	4	9.64	12
16	5	4	-0.91	12
17	5	4	-5.45	30
18	5	4	3.09	20
20	5	4	-0.55	20
21	5	4	1.64	18
22	5	4	1.82	20

23	5	4	-0.55	5
26	5	4	2.73	10
27	5	4	10.00	6
28	5	4	6.18	8
29	5	4	0.91	10
30	5	4	-6.36	30
31	5	4	-5.45	40
32	5	4	-2.73	14
33	5	4	-1.27	11
34	5	4	9.45	10
35	5	4	-3.09	14
37	5	4	3.64	30
38	5	4	8.18	18
39	5	4	-9.09	22

1.39      20.44  
 5.20      10.45  
 0.89      1.79

Mean  
 STDEVA  
 STDEVA/SQRT 34

## **APPENDIX III**

# 1. Statistical analysis for intermittent and continuous ventilation experiments:

## 1.1 Acceptability test

### ANOVA Summary Table for HD:sniff:sniff.expt1.acc.anova

Source of Variation	df	Sum of Squares	Mean Square	F	p	Epsilon Correction
Subjects	29	59964.421	2067.739			
s	1	2464.004	2464.004	6.961	.0133	
Error	29	10264.621	353.952			1.00
m	3	111758.860	37252.953	68.848	.0000	
Error	87	47074.529	541.087			.84
sm	3	396.146	132.049	.357	.7845	
Error	87	32220.729	370.353			.94

**Table 1: simple effects :**

Effect	MSn	DFn	DFe	MSe	F	p
s at m 1	1532.817	1	29	345.161	4.731	.038
s at m 2	680.067	1	29	507.791	1.339	.257
s at m 3	201.667	1	29	315.391	.639	.430
s at m 4	345.600	1	29	296.669	1.165	.289
m at s 1	18694.456	3	87	404.185	46.252	.000
m at s 2	18690.542	3	87	507.254	36.846	.000

**Figure 1. Acceptability for the three tested materials and supply when two different ventilation strategies were applied**

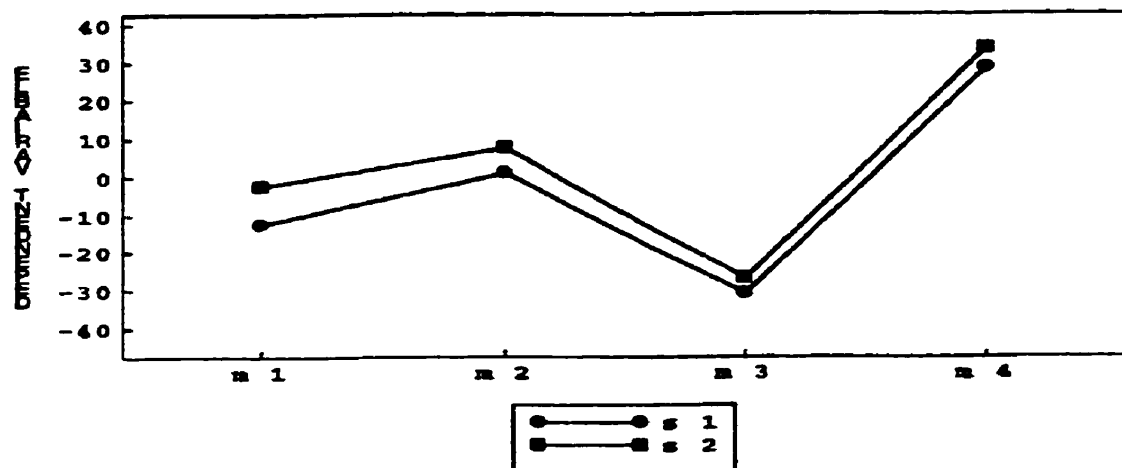

S1 : Intermittent ventilation

S2 : Continuous ventilation

m1 : carpet, m2 : paint, m3 : vinyl, m4 : supply

## 1.2 Odor intensity test

### ANOVA Summary Table for HD:sniff:sniff.expt1.int.anova

Source of Variation	df	Sum of Squares	Mean Square	F	p	Epsilon Correction
Subjects	29	21075.905	726.755			
s	1	902.876	902.876	6.474	.0165	
Error	29	4044.530	139.467			1.00
m	3	19999.878	5666.626	33.243	.0000	
Error	87	17447.332	200.544			.57
sm	3	170.978	56.993	.956	.4171	
Error	87	5184.241	59.589			.38

### Table 2: simple effect

Effect	MSn	DFn	DFe	MSe	F	p
s at m 1	248.067	1	29	147.101	1.686	.204
s at m 2	595.350	1	29	47.384	12.564	.001
s at m 3	194.400	1	29	93.228	2.085	.159
s at m 4	36.038	1	29	30.520	1.181	.286
m at s 1	3508.231	3	87	133.409	26.297	.000
m at s 2	3215.391	3	87	126.724	25.373	.000

Figure 2. Odor intensity for the three tested materials and supply when two different ventilation strategies were applied

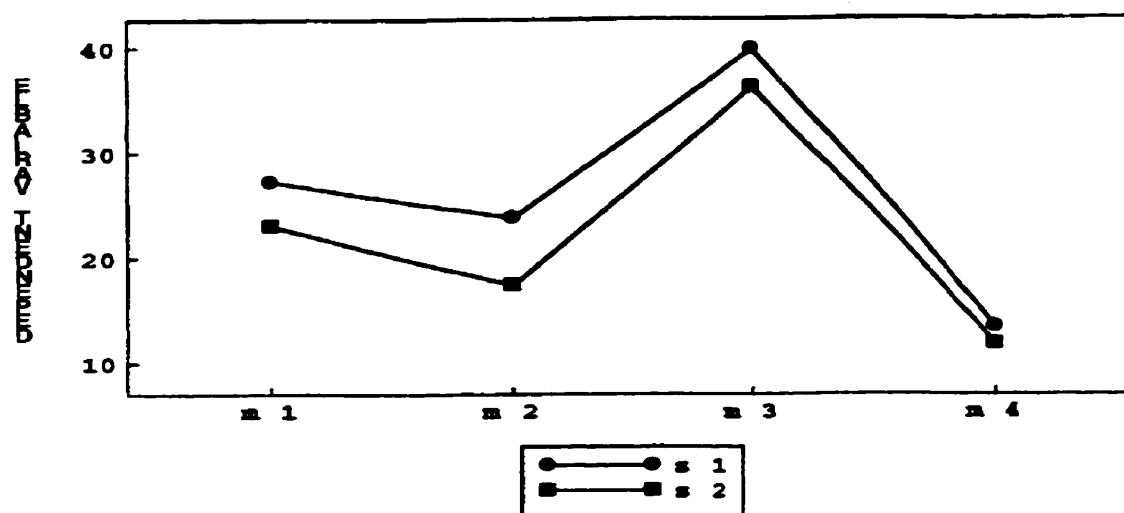

S1 : Intermittent ventilation, S2 : Continuous ventilation  
 m1 : carpet, m2 : paint, m3 : vinyl, m4 : supply

Tukey's HSD post hoc test ( shows which differences between means are significant) :

Upper Triangle: .05 level ; Lower Triangle: .01 level

		A	B	C	D	E	F	G	H
A.	s 2	m 4	X	-	-	S	S	S	S
B.	s 1	m 4	-	X	-	S	S	S	S
C.	s 2	m 2	-	-	X	-	S	S	S
D.	s 2	m 1	S	S	-	X	-	S	S
E.	s 1	m 2	S	S	-	-	X	S	S
F.	s 1	m 1	S	S	S	-	-	X	S
G.	s 2	m 3	S	S	S	S	S	S	X
H.	s 1	m 3	S	S	S	S	S	-	X

## 2. Field investigations

**ANOVA Summary Table for HD:sniff:Accept. offices.Anova**

Source of Variation	df	Sum of Squares	Mean Square	F	p	Epsilon Correction
Subjects	27	37386.780	1384.696			
s	1	1116.005	1116.005	3.558	.0701	
Error	27	8468.494	313.548			1.00
o	2	4065.372	2032.686	6.224	.0037	
Error	54	17635.631	326.586			.95
so	2	346.798	173.399	1.008	.3718	
Error	54	9292.202	172.078			.97

**Table 3. Simple effects**

Effect	MSn	DFn	DFe	MSe	F	p
s at o 1	1188.643	1	27	181.347	6.555	.016
s at o 2	151.143	1	27	244.624	.618	.439
s at o 3	123.018	1	27	231.833	.531	.473
o at s 1	588.226	2	54	283.226	2.077	.135
o at s 2	1617.857	2	54	215.437	7.510	.001

**Figure 3. Acceptability of the air perceived in three investigated offices**

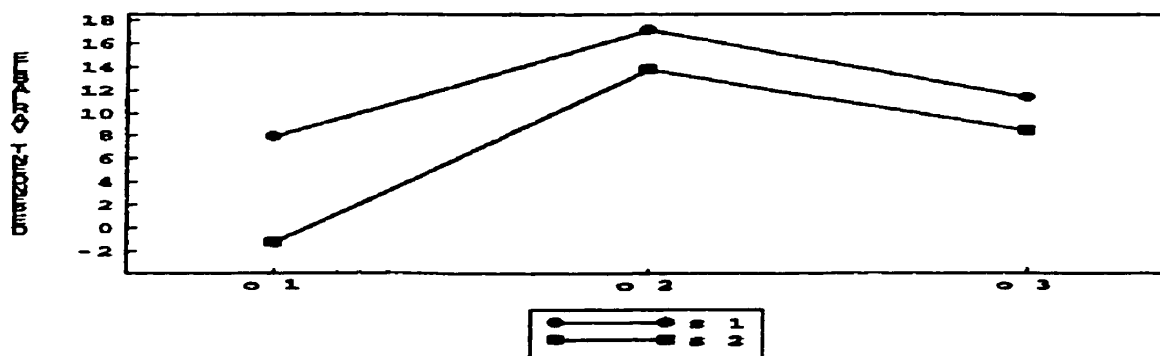

S1 : Continuous ventilation, S2 : Intermittent ventilation

### 3. Dilution experiment

#### 3.1 Acceptability

**ANOVA Summary Table for HD:sniff.dilution.acc.anova**

Source of Variation	df	Sum of Squares	Mean Square	F	p	Epsilon Correction
Subjects	28	131787.007	4706.679			
M	3	93696.632	31232.211	48.619	.0000	
Error	84	53960.841	642.391			.80
D	4	24843.459	6210.865	18.688	.0000	
Error	112	37223.441	332.352			.59
MD	12	24730.801	2060.900	14.766	.0000	
Error	336	46894.297	139.566			.63

**Table 4. Simple effects**

Effect	MSn	DFn	DFe	MSe	F	p
M at D 1	17704.287	3	84	207.668	85.253-	.000
M at D 2	13014.080	3	84	218.664	59.516	.000
M at D 3	5509.034	3	84	245.898	22.404	.000
M at D 4	2023.733	3	84	286.697	7.059	.000
M at D 5	1224.652	3	84	241.730	5.066	.003
D at M 1	1006.300	4	112	172.854	5.822	.000
D at M 2	3536.128	4	112	209.706	16.862	.000
D at M 3	7392.769	4	112	193.205	38.264	.000
D at M 4	458.369	4	112	175.287	2.615	.039

**Upper Triangle: .05 level ; Lower Triangle: .01 level**

		A	B	C	D	E	F	G	H	I	J	K	L	M	N	O	P	Q	R	S	T	
A. M 3	D 1	X	-	S	S	S	S	S	S	S	S	S	S	S	S	S	S	S	S	S	S	S
B. M 3	D 2	-	X	-	S	S	S	S	S	S	S	S	S	S	S	S	S	S	S	S	S	S
C. M 2	D 1	S	-	X	-	-	-	S	S	S	S	S	S	S	S	S	S	S	S	S	S	S
D. M 3	D 3	S	S	-	X	-	-	-	S	S	S	S	S	S	S	S	S	S	S	S	S	S
E. M 1	D 1	S	S	-	-	X	-	-	-	S	S	S	S	S	S	S	S	S	S	S	S	S
F. M 2	D 2	S	S	-	-	-	X	-	-	-	S	S	S	S	S	S	S	S	S	S	S	S
G. M 1	D 2	S	S	-	-	-	-	X	-	-	-	-	-	S	S	S	S	S	S	S	S	S
H. M 3	D 4	S	S	-	-	-	-	-	X	-	-	-	-	S	S	S	S	S	S	S	S	S
I. M 1	D 4	S	S	S	S	-	-	-	-	X	-	-	-	-	S	S	S	S	S	S	S	S
J. M 1	D 3	S	S	S	S	-	-	-	-	-	X	-	-	-	S	S	S	S	S	S	S	S
K. M 2	D 3	S	S	S	S	-	-	-	-	-	-	X	-	-	-	S	S	S	S	S	S	S
L. M 2	D 4	S	S	S	S	S	-	-	-	-	-	-	X	-	-	-	S	S	S	S	S	S
M. M 1	D 5	S	S	S	S	S	-	-	-	-	-	-	-	X	-	-	-	S	S	S	S	S
N. M 3	D 5	S	S	S	S	S	S	-	-	-	-	-	-	-	X	-	-	-	S	S	S	S
O. M 2	D 5	S	S	S	S	S	S	S	-	-	-	-	-	-	-	X	-	-	-	S	S	S
P. M 4	D 4	S	S	S	S	S	S	S	-	-	-	-	-	-	-	-	X	-	-	-	-	-
Q. M 4	D 5	S	S	S	S	S	S	S	S	-	-	-	-	-	-	-	-	X	-	-	-	-
R. M 4	D 3	S	S	S	S	S	S	S	S	S	-	-	-	-	-	-	-	-	X	-	-	-
S. M 4	D 1	S	S	S	S	S	S	S	S	S	S	-	-	-	-	-	-	-	-	X	-	-
T. M 4	D 2	S	S	S	S	S	S	S	S	S	S	S	-	-	-	-	-	-	-	-	X	-

M1 : paint, M2 :carpet, M3 : vinyl, M4 : supply

D1,D2,D3,D4 and D5 : dilution correspond to dilution factors equal to : 1,2,6,9 and 16

3.2 Odor intensity

**ANOVA Summary Table for HD:Sniff.dilution.int.anova**

Source of Variation	df	Sum of Squares	Mean Square	F	p	Epsilon Correction
Subjects	27	23854.247	883.491			
M	3	8447.774	2815.925	18.436	.0000	
Error	81	12372.281	152.744			.51
D	4	5598.507	1399.627	20.528	.0000	
Error	108	7327.759	67.850			.42
MD	12	3930.126	327.510	8.338	.0000	
Error	324	12726.397	39.279			.27

Table 5. Simple effects

Effect	MSn	DFn	DFe	MSe	F	p
M at D 1	1987.533	3	81	99.280	20.020	.000
M at D 2	1564.092	3	81	82.425	18.976	.000
M at D 3	417.741	3	81	72.525	5.760	.001
M at D 4	134.002	3	81	34.992	3.829	.013
M at D 5	22.595	3	81	20.638	1.095	.356
D at M 1	245.390	4	108	31.642	7.755	.000
D at M 2	636.427	4	108	63.364	10.044	.000
D at M 3	1482.777	4	108	82.151	18.049	.000
D at M 4	17.564	4	108	8.530	2.059	.091

**Upper Triangle: .05 level ; Lower Triangle: .01 level**

	A	B	C	D	E	F	G	H	I	J	K	L	M	N	O	P	Q	R	S	T		
A. M 4 D 2	X	-	-	-	-	-	-	-	-	-	-	-	-	S	S	S	S	S	S	S		
B. M 4 D 3	-	X	-	-	-	-	-	-	-	-	-	-	-	S	S	S	S	S	S	S		
C. M 4 D 1	-	-	X	-	-	-	-	-	-	-	-	-	-	S	S	S	S	S	S	S		
D. M 4 D 5	-	-	-	X	-	-	-	-	-	-	-	-	-	-	-	-	S	S	S	S		
E. M 4 D 4	-	-	-	-	X	-	-	-	-	-	-	-	-	-	-	-	S	S	S	S		
F. M 2 D 5	-	-	-	-	-	X	-	-	-	-	-	-	-	-	-	-	S	S	S	S		
G. M 2 D 3	-	-	-	-	-	-	X	-	-	-	-	-	-	-	-	-	S	S	S	S		
H. M 1 D 5	-	-	-	-	-	-	-	X	-	-	-	-	-	-	-	-	S	S	S	S		
I. M 3 D 5	-	-	-	-	-	-	-	-	X	-	-	-	-	-	-	-	S	S	S	S		
J. M 2 D 4	-	-	-	-	-	-	-	-	-	X	-	-	-	-	-	-	S	S	S	S		
K. M 1 D 4	-	-	-	-	-	-	-	-	-	-	X	-	-	-	-	-	S	S	S	S		
L. M 1 D 3	-	-	-	-	-	-	-	-	-	-	-	X	-	-	-	-	S	S	S	S		
M. M 3 D 4	S	-	-	-	-	-	-	-	-	-	-	-	X	-	-	-	S	S	S	S		
N. M 2 D 2	S	S	S	-	-	-	-	-	-	-	-	-	-	X	-	-	S	S	S	S		
O. M 1 D 2	S	S	S	-	-	-	-	-	-	-	-	-	-	-	X	-	S	S	S	S		
P. M 3 D 3	S	S	S	S	S	S	-	-	-	-	-	-	-	-	-	X	-	S	S	S		
Q. M 1 D 1	S	S	S	S	S	S	S	S	-	-	-	-	-	-	-	-	X	-	S	S		
R. M 2 D 1	S	S	S	S	S	S	S	S	S	S	S	S	S	-	-	-	-	X	-	S		
S. M 3 D 2	S	S	S	S	S	S	S	S	S	S	S	S	S	S	S	S	S	S	S	-	X	
T. M 3 D 1	S	S	S	S	S	S	S	S	S	S	S	S	S	S	S	S	S	S	S	S	-	X

M1 : paint, M2 :carpet, M3 : vinyl, M4 : supply

D1,D2,D3,D4 and D5 : dilution correspond to dilution factors equal to : 1,2,6,9 and 16



#### 4. Additive effect of building products

**ANOVA Summary Table for HD:sniff:additive impacts**

Source of Variation	df	Sum of Squares	Mean Square	F	p	Epsilon Correction
Subjects	33	7591.889	230.057			
G	1	.008	.008	.000	.9897	
Error	33	1495.550	45.320			1.00
M	2	20.506	10.253	.983	.3795	
Error	66	688.250	10.428			.98
GM	2	104.396	52.198	4.158	.0199	
Error	66	828.580	12.554			.74
D	4	2085.767	521.442	29.360	.0000	
Error	132	2344.340	17.760			.59
GD	4	24.917	6.229	.695	.5970	
Error	132	1183.799	8.968			.87
MD	8	53.827	6.728	.597	.7799	
Error	264	2974.439	11.267			.67
GMD	8	95.254	11.907	1.052	.3977	
Error	264	2989.227	11.323			.59

#### Tukey's HSD post hoc test

Upper Triangle: .05 level ; Lower Triangle: .01 level

		A	B	C	D	E	F
A. G 1	M 2	X	-	-	-	-	-
B. G 2	M 3	-	X	-	-	-	-
C. G 2	M 1	-	-	X	-	-	-
D. G 1	M 3	-	-	-	X	-	-
E. G 2	M 2	-	-	-	-	X	-
F. G 1	M 1	-	-	-	-	-	X

G1 : panel participating in the test for single materials

M1 : paint, M2 : carpet, M3 : PVC

G2 : panel participating in the test for combined materials

M1 : PVC & carpet, M2 : paint & PVC, M3: paint & carpet

### ANOVA Summary Table for HD:sniff:carpet,vinyl and C+U

Source of Variation	df	Sum of Squares	Mean Square	F	p	Epsilon Correction
Subjects	33	3773.856	114.359			
m	2	51.606	25.803	1.541	.2217	
Error	66	1104.773	16.739			.81
d	4	1290.118	322.530	20.651	.0000	
Error	132	2061.599	15.618			.64
md	8	45.738	5.717	.464	.8807	
Error	264	3252.077	12.318			.77

### Upper Triangle: .05 level ; Lower Triangle: .01 level

	A	B	C
A. m 2	X	-	-
B. m 3	-	X	-
C. m 1	-	-	X

Table 6. simple effects

Effect	MSn	DFn	DFe	MSe	F	p
m at d 1	31.474	2	66	12.474	2.523	.088
m at d 2	5.013	2	66	16.069	.312	.733
m at d 3	3.650	2	66	9.831	.371	.691
m at d 4	7.971	2	66	16.058	.496	.611
m at d 5	.564	2	66	11.581	.049	.952
d at m 1	147.440	4	132	12.888	11.440	.000
d at m 2	75.628	4	132	15.777	4.793	.001
d at m 3	110.897	4	132	11.590	9.569	.000

**m1: Carpet, m2 : Vinyl, m3: carpet & vinyl**

### ANOVA Summary Table for HD:sniff:Paint,Carpetand P+C

Source of Variation	df	Sum of Squares	Mean Square	F	p	Epsilon Correction
Subjects	33	3573.379	108.284			
m	2	77.794	38.897	1.814	.1710	
Error	66	1414.991	21.439			.95
d	4	1250.557	312.639	24.828	.0000	
Error	132	1662.183	12.592			.71
md	8	96.257	12.032	1.037	.4082	
Error	264	3062.163	11.599			.66

Upper Triangle: .05 level ; Lower Triangle: .01 level

	A	B	C
A. m 1	X	-	-
B. m 3	-	X	-
C. m 2	-	-	X

Table 7. Simple effects

Effect	MSn	DFn	DFe	MSe	F	p
m at d 1	35.076	2	66	15.529	2.259	.113
m at d 2	3.699	2	66	13.825	.268	.766
m at d 3	1.052	2	66	9.129	.115	.891
m at d 4	43.701	2	66	14.448	3.025	.055
m at d 5	3.497	2	66	14.905	.235	.792
d at m 1	113.404	4	132	12.366	9.171	.000
d at m 2	147.440	4	132	12.888	11.440	.000
d at m 3	75.860	4	132	10.536	7.200	.000

**m1 : paint, m2 : carpet, m3: paint & carpet**

## **APPENDIX IV**

### Instructions for subjects

Please read carefully: Remember, you are a member of a panel, and your responses are important.

- The panel members should come with a good personal hygiene and without perfume.
- The acceptability scales that you will be using should be considered continuous and without categories. Mark anywhere on the vertical line to indicate your best estimate.
- The evaluation of indoor air should be made from the initial perception, and acceptability ratings should be marked within the first 30 seconds after entering a room.
- No communication what so ever on air quality is allowed during rating procedures, nor during your walks.  
Please wait until you have finished all buildings.

When assessing the odor intensity you should apply a ratio scale with outside air as a reference. Odor intensity of outside air should be given the value of 10. More intense odors should be given higher numbers and less intense odors smaller numbers. The number should be proportional to odor intensity.  
**Example:** If you find the odor to be five times as intense as outside air you should assign the value 50, and if you find it 5 times less intense you should use the number 2.

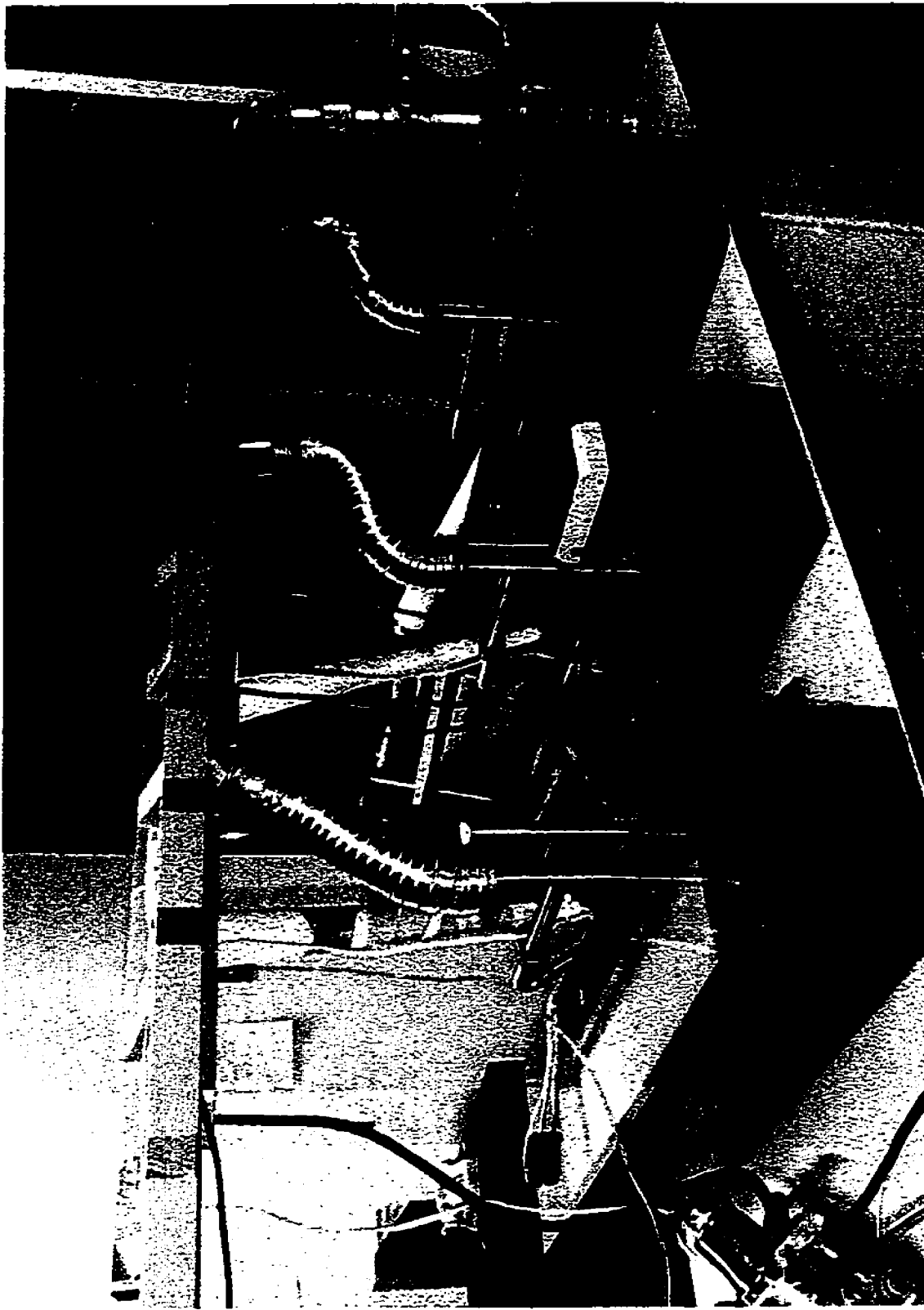

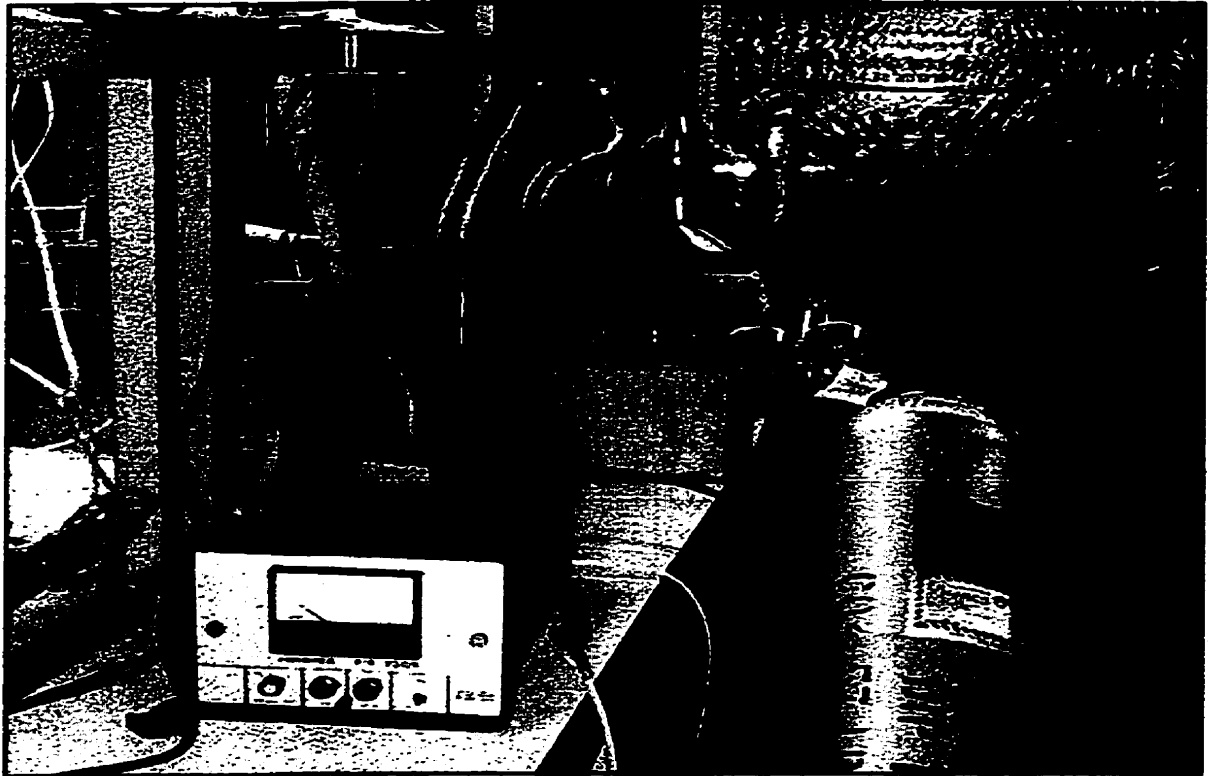

**Test chambers during calibration process using CO<sub>2</sub> as a tracer gas**



**Verification of the air velocity and air flow at the end of the diffuser**

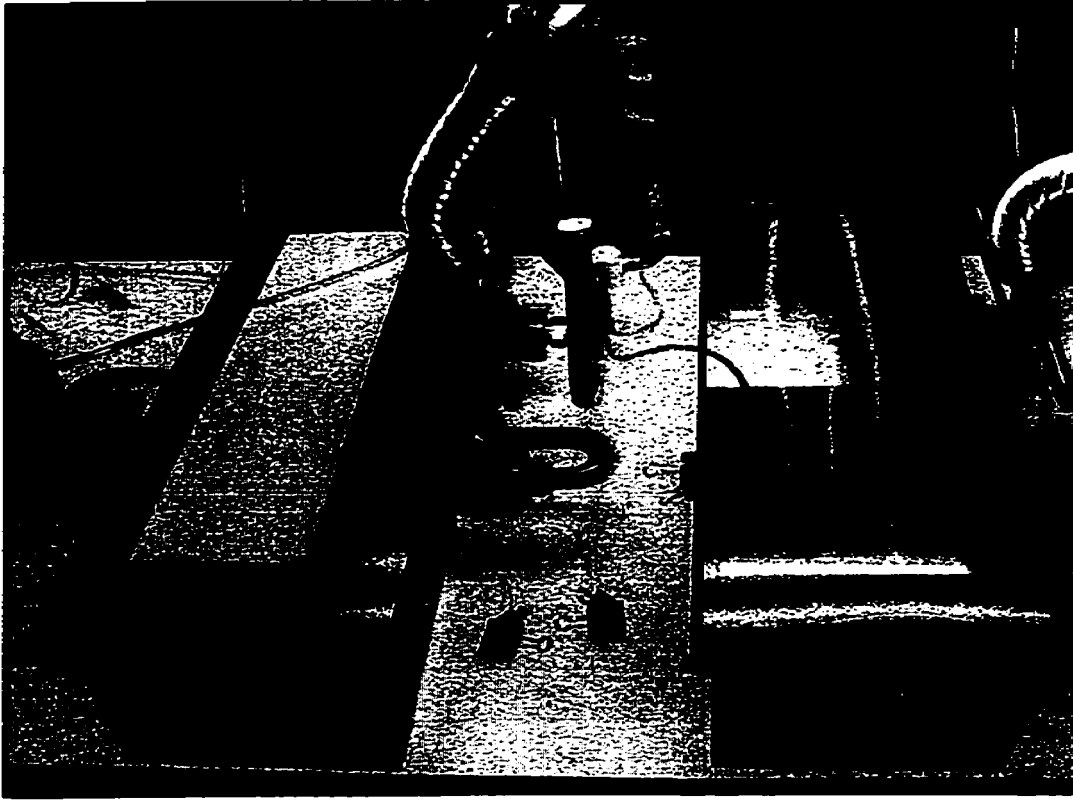

**Samples of carpet and painted gypsum board in the test chambers**

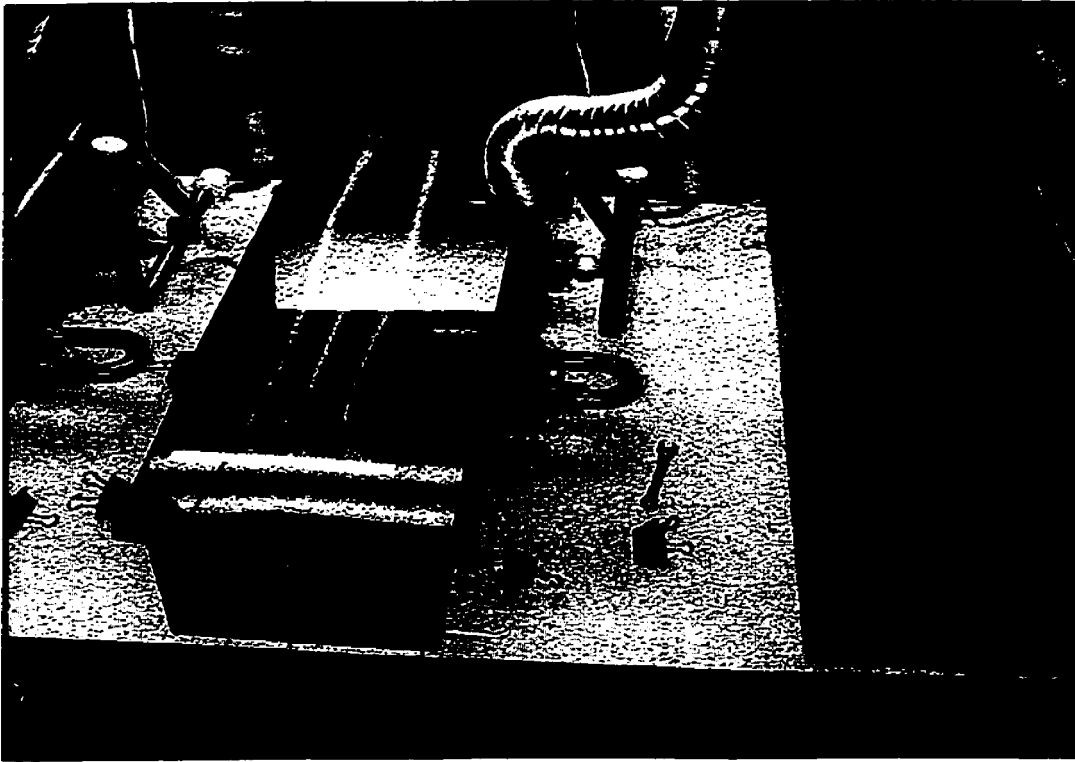

**Samples of carpet and PVC in the test chambers**



During the experiment, the test chambers were covered to hide the tested material from ~~the view of the panel~~

